



Presses & Automation  
SINCE 1975



**AZ-SF**  
**Servo Straightener feeder**



## AZ-SF2

### Servo Motorized Straightener & Feeder



#### Standard features

- Motorized Straightener & Feeder combination units
- Motorized pass-line adjustment
- Standard feed direction from left to right
- Omron Servo Driven
- Pneumatic Pilot Release
- 4140 Steel rolls hardened to 58-64HRC
- Up to 1000 job storage as standard
- Press mounted

#### Optional features

- GAG OUTPUTS (6 or 12)
- Sequential feeding (up to 20 sequences)
- Digital straightener adjustment (memory from one job to another)
- Right to left feeding direction
- Floor racking
- Remote screen
- Wireless remote



## AZ-SF2

### Servo Motorized Straightener & Feeder



- Space Saving line allows to reduce line length of more than 30% than typical line
- Combine any of our Decoiler to integrate the whole line

- Pneumatic coil threading features
- High quality hardened servo/straightener rolls
- Pneumatic pilot release features
- Double handles for straightener adjustment
- Pneumatic feeder release & Pneumatic Straightener release
- Electric pass line adjustment +/-100mm
- Accuracy of +/- 0.003"
- Straightener configurations : 4 top 3 bottom
- Several controller options such as feed output controller, custom counter, etc.
- High quality timing belt design
- Optional Oiling system
- Optional Advanced controller

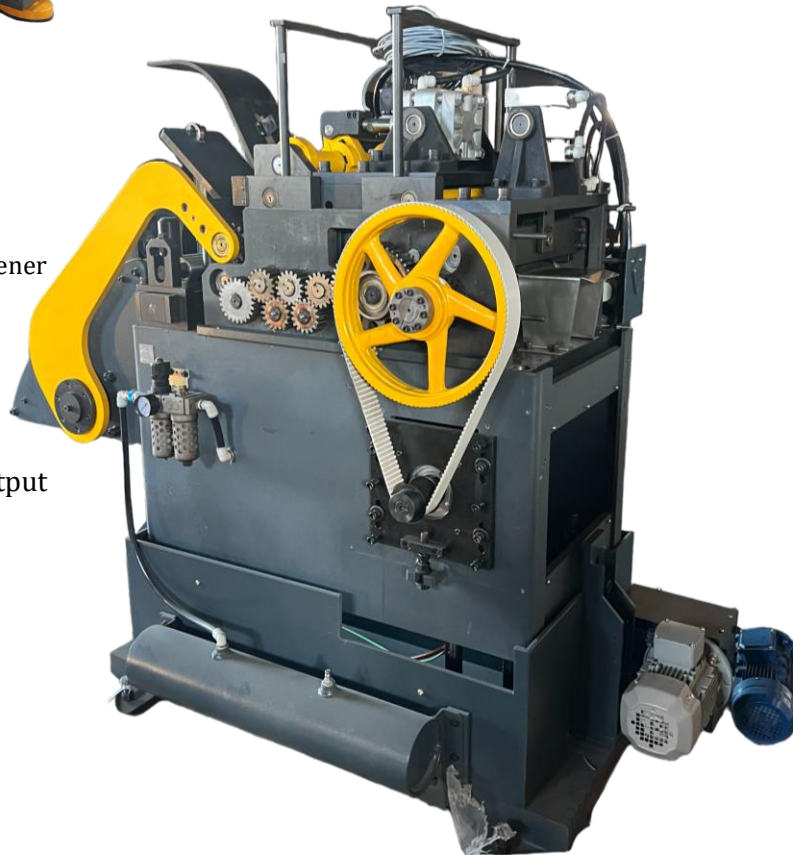



# AZ-SF2

## Servo Motorized Straightener & Feeder

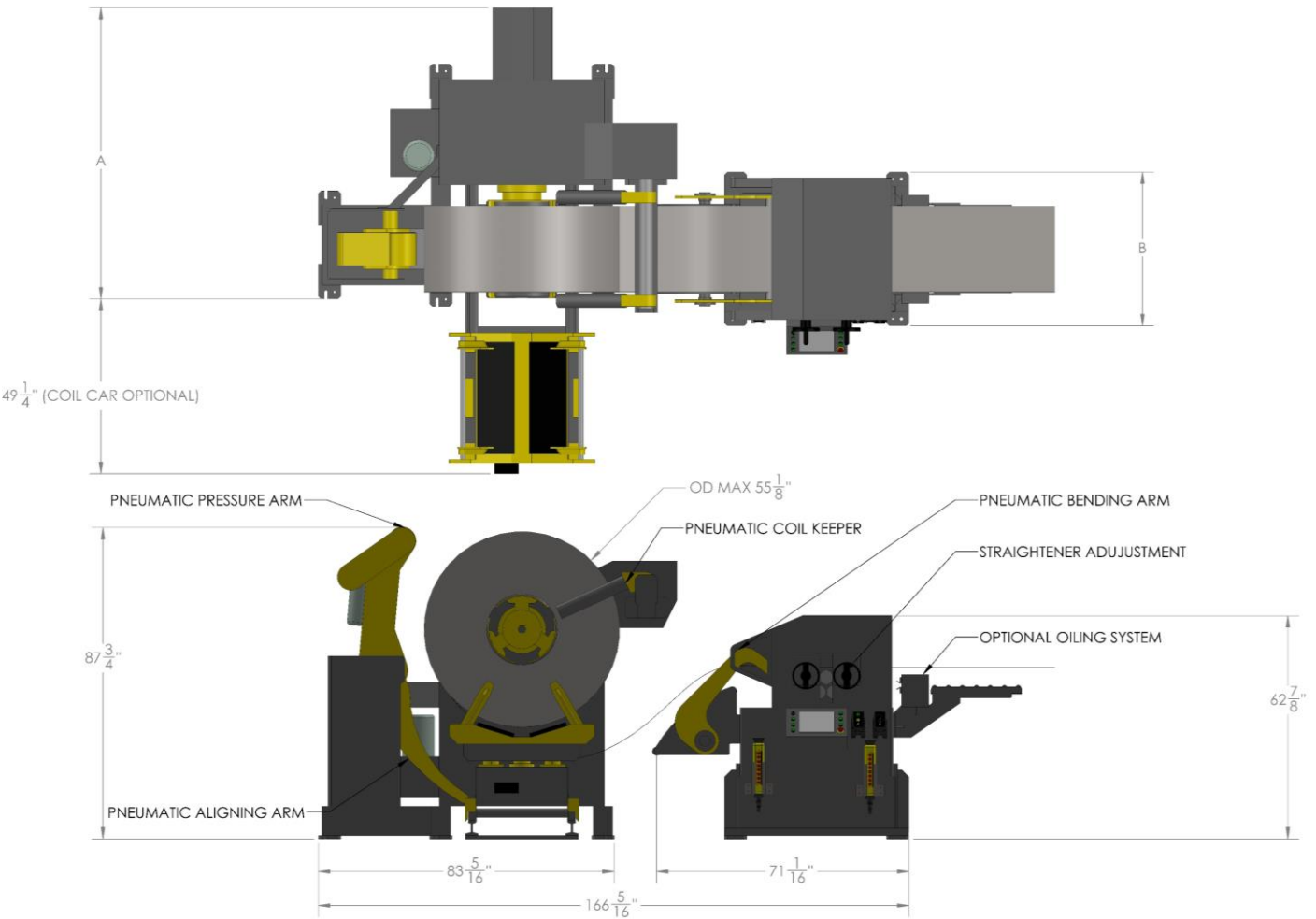



# AZ-SF

## Servo Motorized Straightener & Feeder

Model→ Parameter↓	Unit	AZ-SF2-400	AZ-SF2-600	AZ-SF2-800	AZ-SF2-1000
<b>Min width</b>	<b>INCH</b>	<b>2,750</b>			
<b>Max Width</b>	INCH	15,75	23,625	31,500	39,38
<b>Thickness MIN</b>	INCH	0,020			
<b>Thickness MAX</b>	INCH	0,18			
<b>Pass-line MIN (FROM FLOOR)</b>	INCH	39,37			
<b>Pass-line MAX (FROM FLOOR)</b>	INCH	55,12			
<b>Feeding rolls diameter</b>	INCH	3,465			
<b>Starighthener rolls diameter</b>	INCH	2,677			
<b>Straightener rolls configuration</b>		4 top 3 bottom			
<b>Pilot Release</b>		Pneumatic			
<b>Max speed</b>	INCH/S	19,69			
<b>Air</b>	PSI	80,00			
<b>VOLTAGE</b>	VAC	480VAC-3PH			
<b>SERVO MOTOR</b>	KW	5,5	5,5	5,5	7,5





# AZ-SF2

Straightening & feeding capacity

### Straightening Capacities for SF2 models

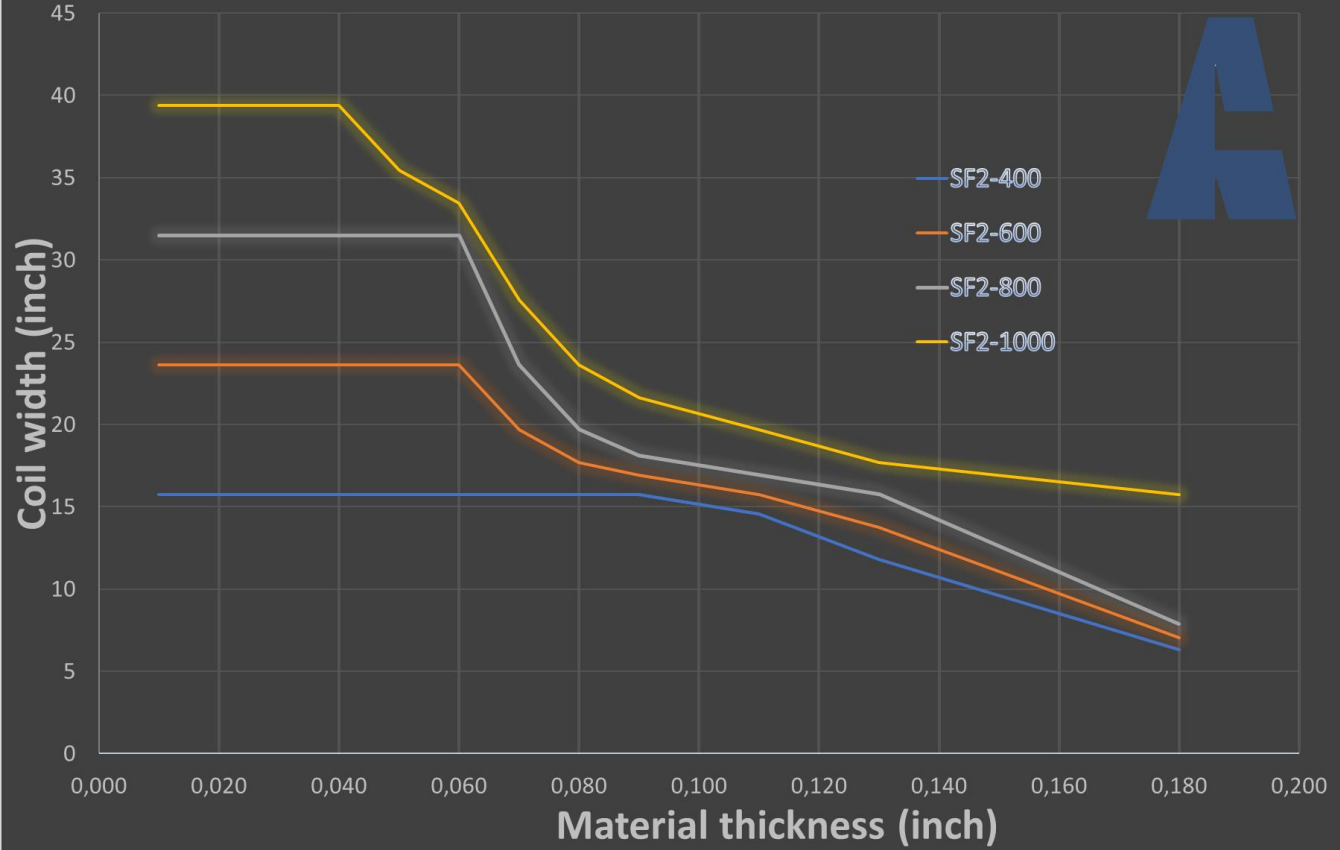

THICKNESS (INCH)	AZ SF2-400	AZ SF2-600	AZ-SF2-800	AZ-SF2-1000
0,010	15,75	23,625	31,5	39,375
0,040	15,75	23,625	31,5	39,375
0,050	15,75	23,625	31,5	35,4375
0,060	15,75	23,625	31,5	33,4375
0,070	15,75	19,6875	23,625	27,5625
0,080	15,75	17,6875	19,6875	23,625
0,090	15,75	16,9375	18,125	21,625
0,110	14,5625	15,75	16,9375	19,6875
0,130	11,8125	13,75	15,75	17,6875
0,180	6,3125	7,0625	7,875	15,75





# AZ-SF

## Servo Motorized Straightener & Feeder

Model→ Parameter↓	Unit	AZ-SF3-400	AZ-SF3-600	AZ-SF3-800	AZ-SF3-1000
<b>Min width</b>	<b>INCH</b>	<b>2,750</b>			
<b>Max Width</b>	INCH	15,75	19,625	23,625	39,38
<b>Thickness MIN</b>	INCH	0,020			
<b>Thickness MAX</b>	INCH	0,24			
<b>Pass-line MIN (FROM FLOOR)</b>	INCH	39,37			
<b>Pass-line MAX (FROM FLOOR)</b>	INCH	55,12			
<b>Feeding rolls</b>	INCH	3,465			
<b>Starighthener rolls</b>	INCH	2,677			
<b>Straightener rolls configuration</b>		4 top 3 bottom			
<b>Pilot Release</b>		Pneumatic			
<b>Max speed</b>	INCH/S	19,69			
<b>Air</b>	PSI	80,00			
<b>VOLTAGE</b>	VAC	480VAC-3PH			
<b>SERVO MOTOR</b>	KW	5,5	5,5	5,5	7,5
<b>Passline Motor</b>	KW	2	2	2	2





# AZ-SF3

## Straightening & feeding capacity

Straightening Capacities for AZ-SF3 models

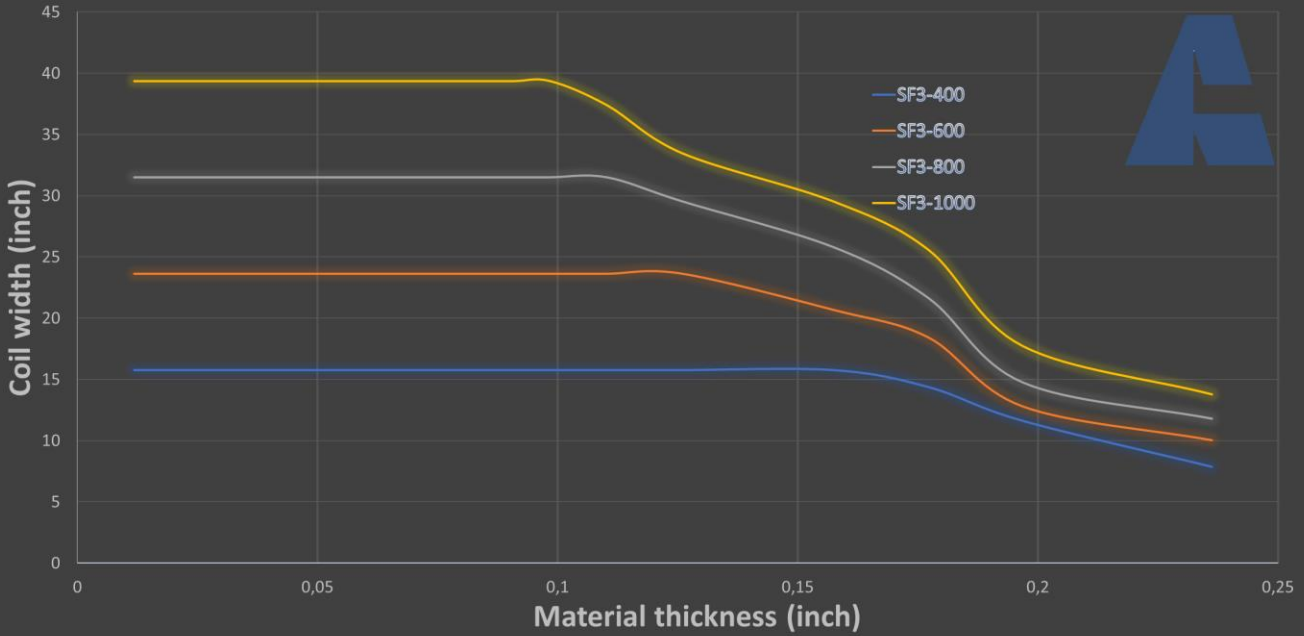

<b>THICKNESS (INCH)</b>	<b>AZ-SF3-400</b>	<b>AZ-SF3-600</b>	<b>AZ-SF3-800</b>	<b>AZ-SF3-1000</b>
<b>0,01</b>	<b>15,75</b>	<b>23,62</b>	<b>31,5</b>	<b>39,37</b>
<b>0,04</b>	<b>15,75</b>	<b>23,62</b>	<b>31,5</b>	<b>39,37</b>
<b>0,05</b>	<b>15,75</b>	<b>23,62</b>	<b>31,5</b>	<b>39,37</b>
<b>0,05</b>	<b>15,75</b>	<b>23,62</b>	<b>31,5</b>	<b>39,37</b>
<b>0,08</b>	<b>15,75</b>	<b>23,62</b>	<b>31,5</b>	<b>39,37</b>
<b>0,09</b>	<b>15,75</b>	<b>23,62</b>	<b>31,5</b>	<b>39,37</b>
<b>0,1</b>	<b>15,75</b>	<b>23,62</b>	<b>31,5</b>	<b>39,37</b>
<b>0,11</b>	<b>15,75</b>	<b>23,62</b>	<b>31,5</b>	<b>37,4</b>
<b>0,13</b>	<b>15,75</b>	<b>23,62</b>	<b>29,53</b>	<b>33,46</b>
<b>0,16</b>	<b>15,75</b>	<b>20,67</b>	<b>25,79</b>	<b>29,53</b>
<b>0,18</b>	<b>14,37</b>	<b>18,43</b>	<b>21,65</b>	<b>25,59</b>
<b>0,2</b>	<b>11,61</b>	<b>12,8</b>	<b>14,76</b>	<b>17,72</b>
<b>0,24</b>	<b>7,87</b>	<b>10,04</b>	<b>11,81</b>	<b>13,78</b>







## *Azimuth turnkey solution*

We specialized in complete turnkey press line solution & design, which allows our customer to provide us complete contract in integrating their press solution. We supply & manufacture;

**Presses**

**Tooling**

**Custom controller solution**

**Feed-line**

**Safety integration**



