

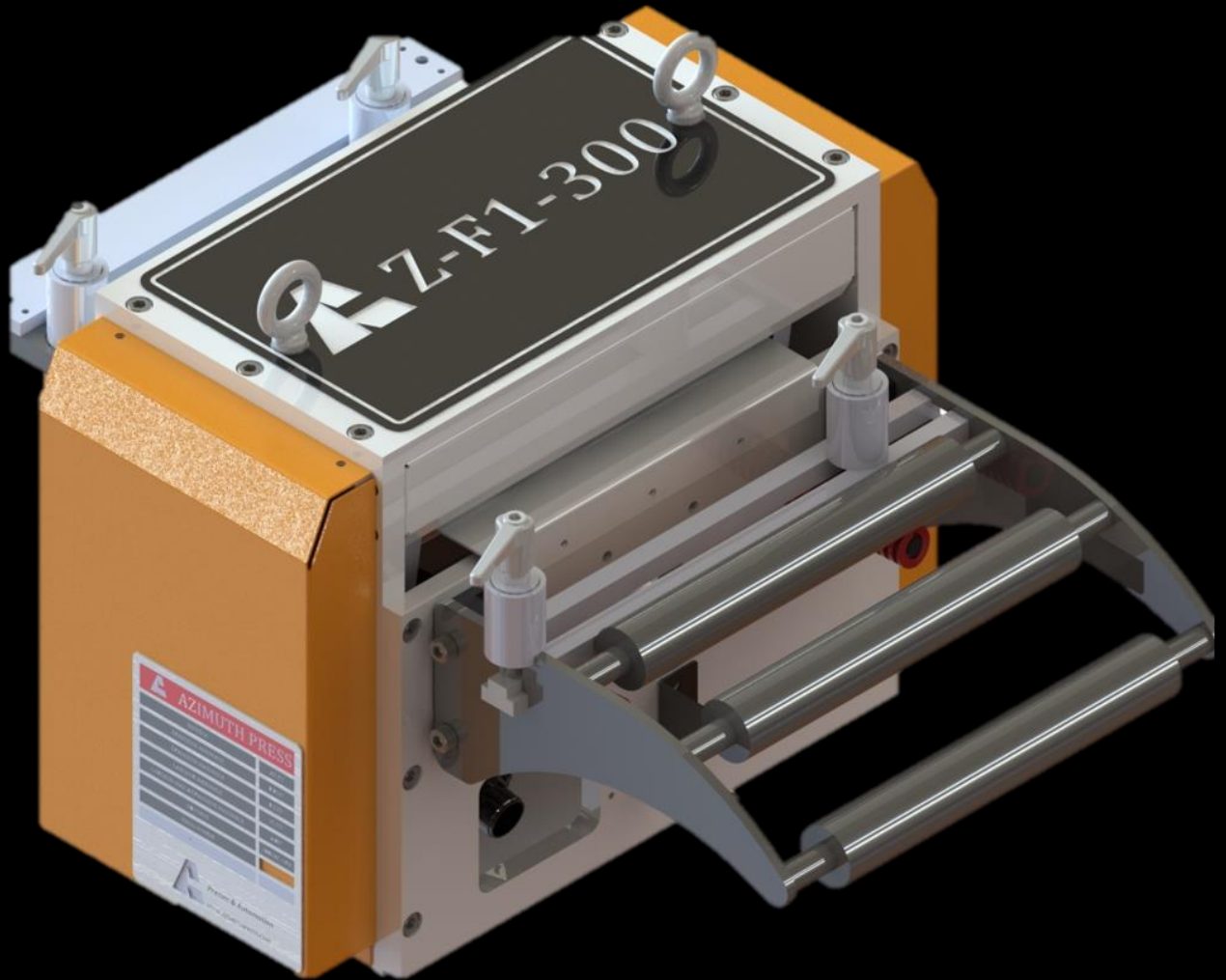

Presses & Automation
SINCE 1975



AZ-F1, F2 & F3 series
Servo feeder



AZ-F1, F2 & F3

Servo rolls feeder

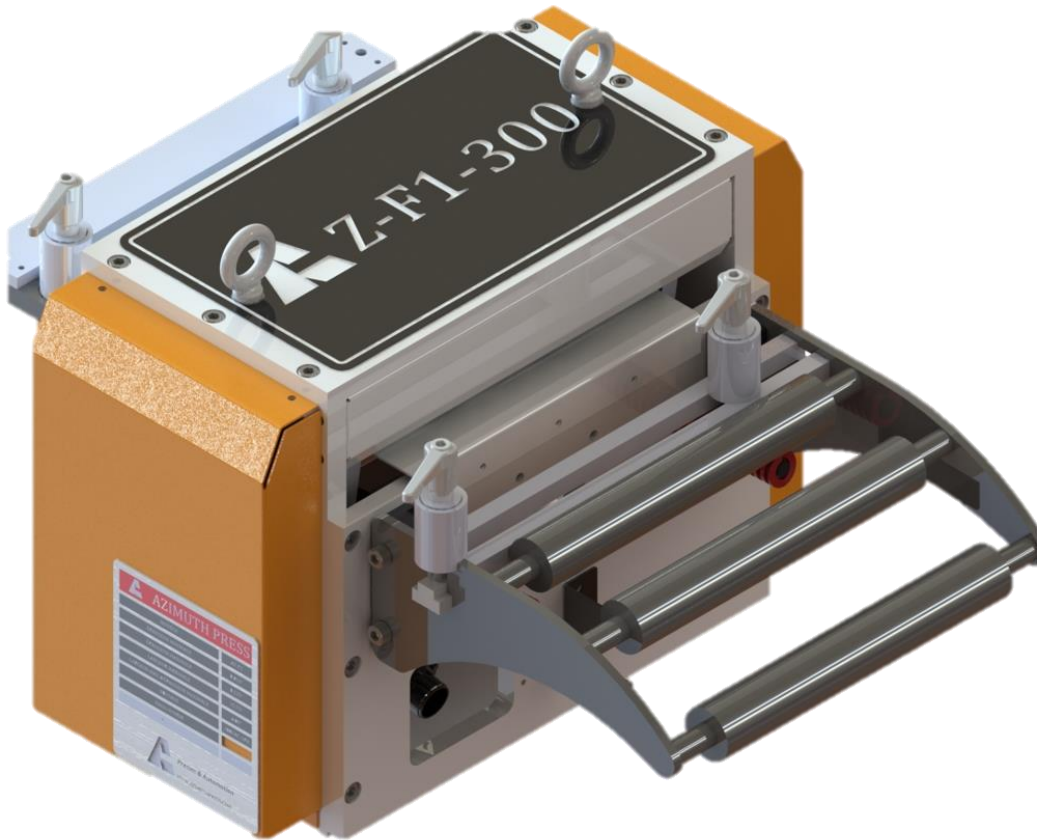

Standard features

- Servo motorized Feeder
- Omron Servo Driven
- Pneumatic Pilot Release as standard
- 4140 Steel rolls hardened to 58-64HRC
- Material thickness from 0.008in to 0.250in
- Automatic, manual and set-up mode
- Bolster plate mount
- Azimuth feed interface

Optional features

- GAG OUTPUTS (6 or 12)
- Sequential feeding (up to 20 sequences)
- Extra job storage (up to 1000 jobs)
- Floor racking
- Remote screen
- Wireless remote Azimuth advanced feed interface



AZ-F1, F2 & F3

Standard roll feeder

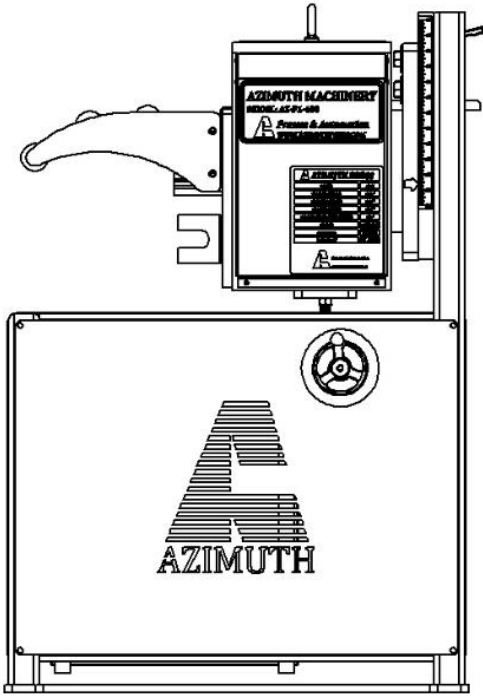

Optional floor stand. Standard is bolster mounted

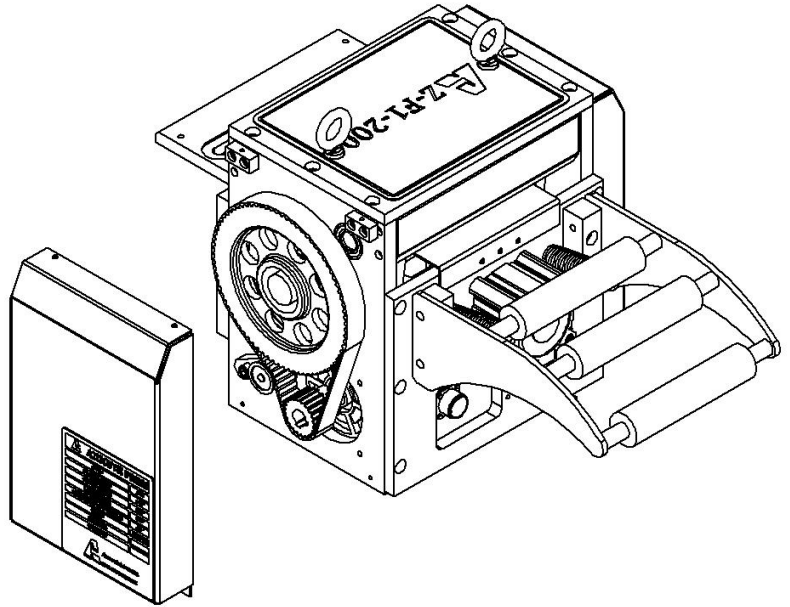

Belt driven upper rolls with zero backlash gears between rolls

Feed direction can be changed from right to left or Right to left

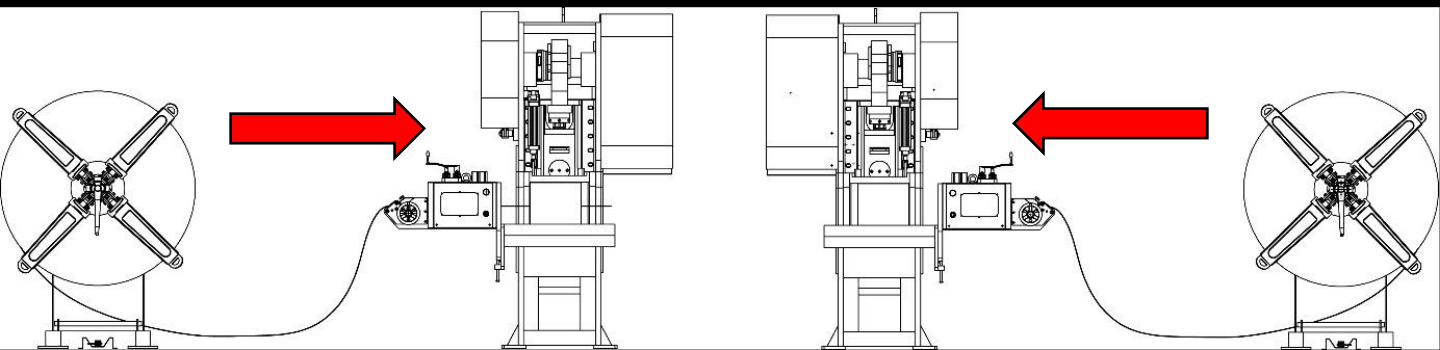



AZ-F1, F2 & F3

Servo rolls feeder

Model→ Parameter↓	Unit	AZ-F1-200	AZ-F1-300	AZ-F1-400	AZ-F1-600	AZ-F1-800	AZ-F1-1000
Coil Width	inch	7.875	11.75	15.75	23.625	31.5	39.375
Thickness MIN	inch	0.008					
Thickness MAX	inch	0.126					
Rolls diameter	inch	3.5					
Pilot release		Pneumatic					
Accuracy	inch	± 0.004					
MAX SPEED	inch/s	13.00					
MOTOR POWER	HP	2.0		2.7		4.0	5.4

Model→ Parameter↓	Unit	AZ-F2-200	AZ-F2-300	AZ-F2-400	AZ-F2-600	AZ-F2-800	AZ-F2-1000
Coil Width	inch	7.875	11.75	15.75	23.625	31.5	39.375
Thickness MIN	inch	0.020					
Thickness MAX	inch	0.177					
Rolls diameter	inch	3.5					
Pilot release		Pneumatic					
Accuracy	inch	± 0.004					
MAX SPEED	inch/s	13.00					
MOTOR POWER	HP	2.0		2.7		4.0	5.4

Model→ Parameter↓	Unit	AZ-F3-300	AZ-F3-400	AZ-F3-600
Coil Width	inch	11.75	15.75	23.625
Thickness MIN	inch	0.024		
Thickness MAX	inch	0.236		
Rolls diameter	inch	3.5		
Pilot release		Pneumatic		
Accuracy	inch	± 0.004		
MAX SPEED	inch/s	13.00		
MOTOR POWER	HP	2.0	2.7	4.0





AZ-F1

Standard roll feeder

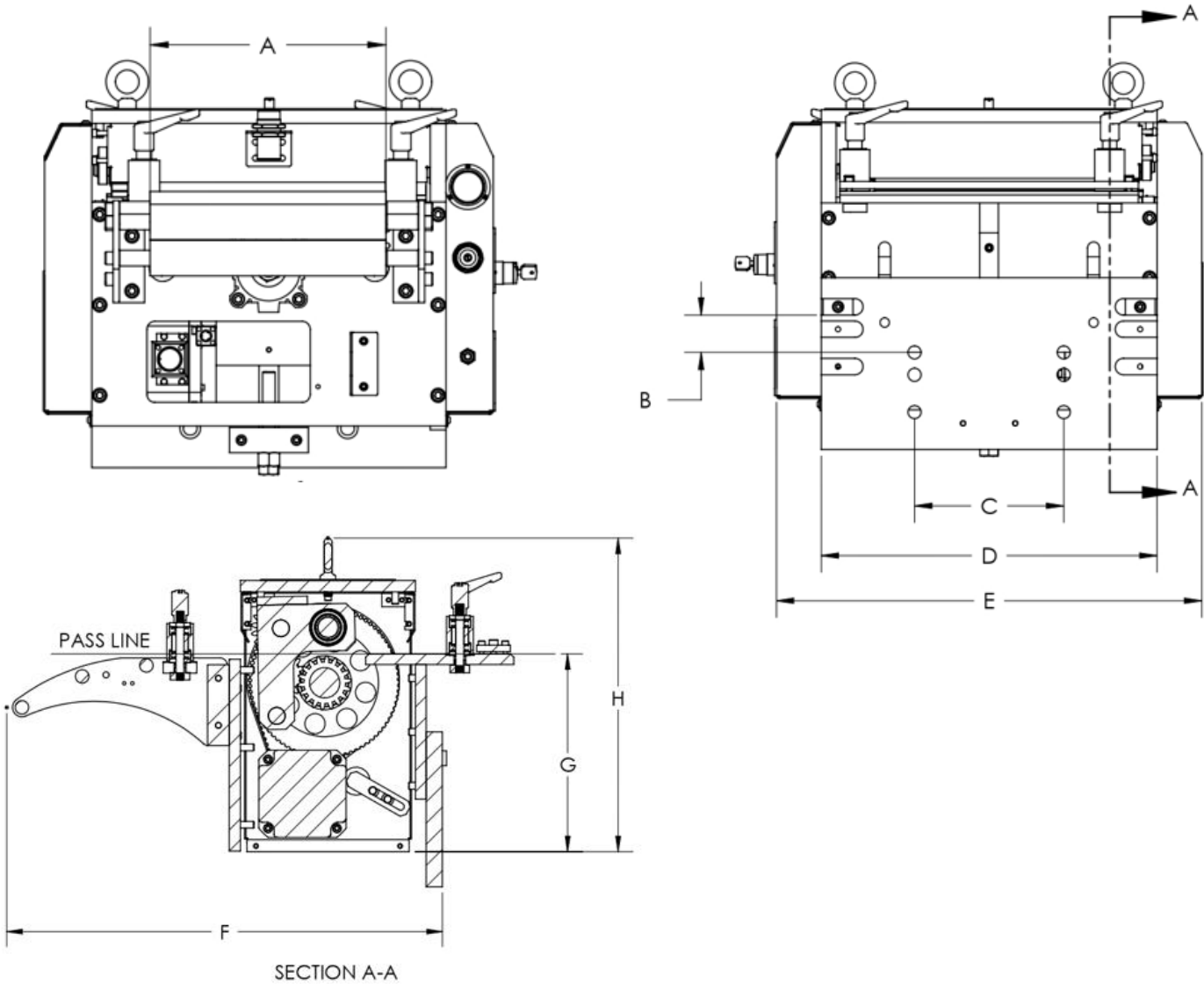

MODEL	WEIGHT	A	B	C	D	E	F	G	H
AZ-F1-200	50 kg	200 mm	50 mm	200 mm	350 mm	470 mm	651.5 mm	312 mm	448.48 mm
AZ-F1-300	60 kg	300 mm	50 mm	200 mm	450 mm	570 mm	651.5 mm	299 mm	469.66 mm
AZ-F1-400	70 kg	400 mm	50 mm	140 mm/340 mm	550 mm	670 mm	651.5 mm	299 mm	469.66 mm
AZ-F1-500	80 kg	500 mm	50 mm	200 mm/450 mm	650 mm	770 mm	651.5 mm	299 mm	469.66 mm
AZ-F1-600	90 kg	600 mm	50 mm	200 mm/600 mm	750 mm	870 mm	651.5 mm	299 mm	469.66 mm





Azimuth turnkey solution

We specialized in complete turnkey press line solution & design, which allows our customer to provide us complete contract in integrating their press solution. We supply & manufacture;

Presses

Tooling

Custom controller solution

Feed-line

Safety integration



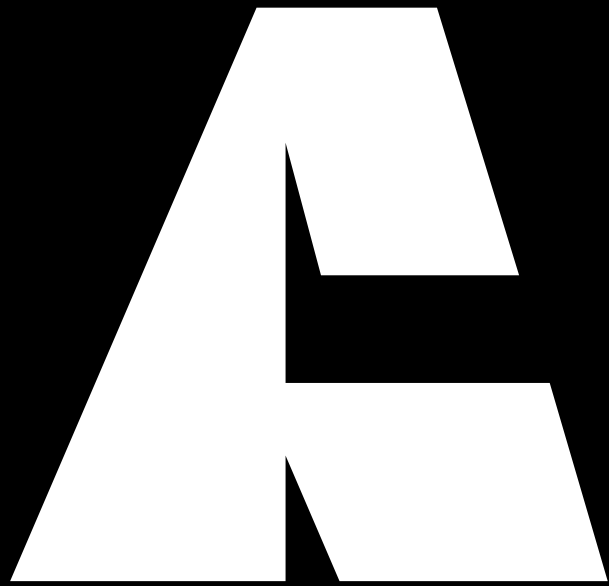

Presses & Automation