

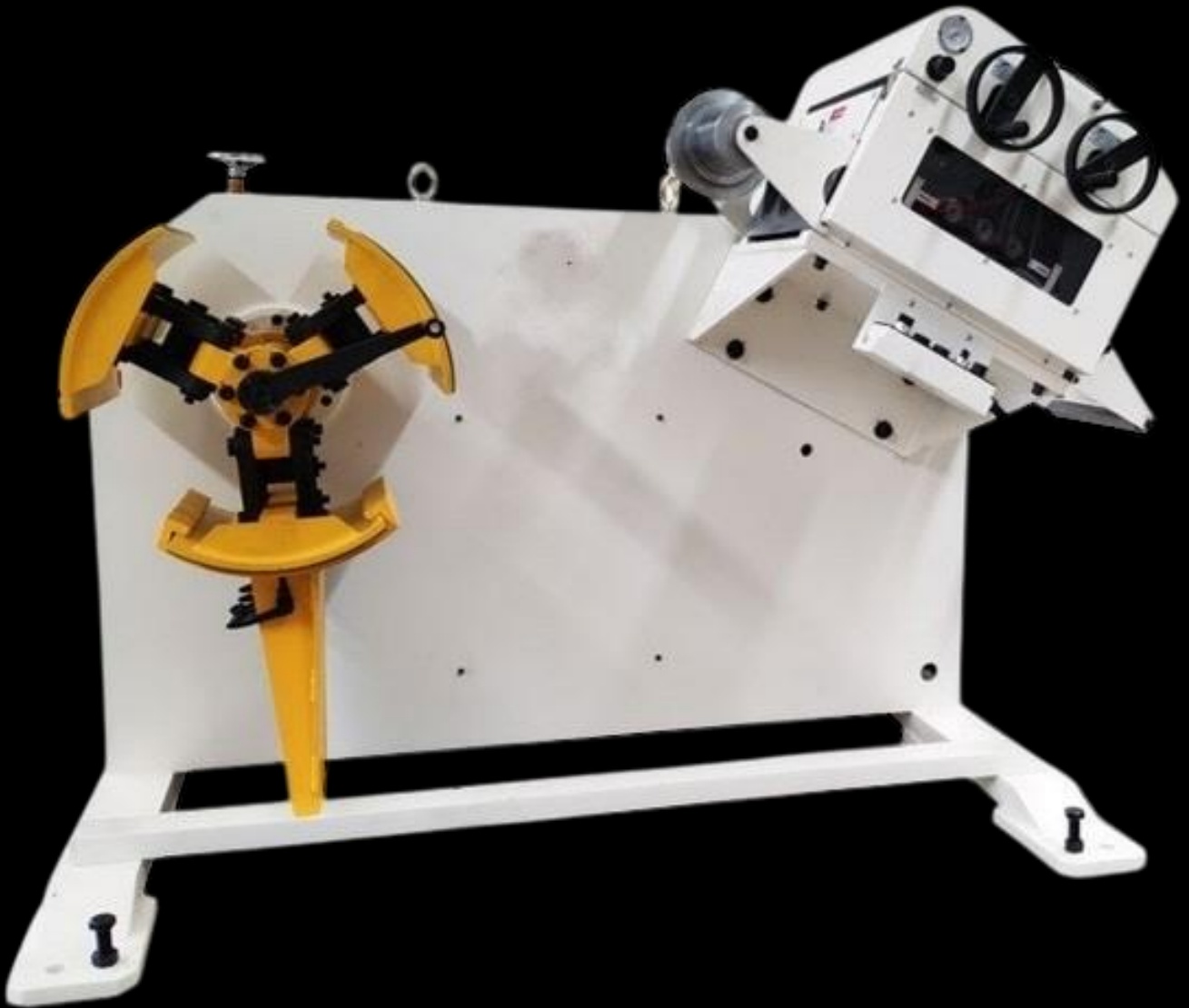

Presses & Automation
SINCE 1975

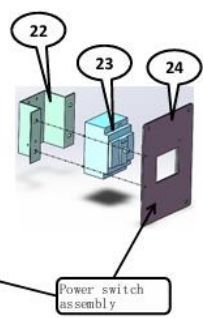

AZ-DS2
Spare Parts

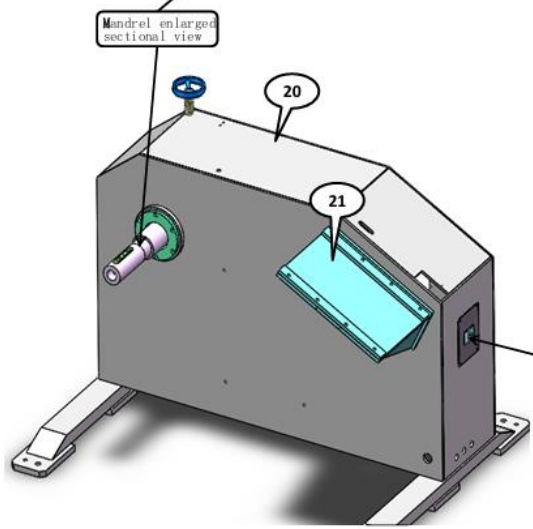
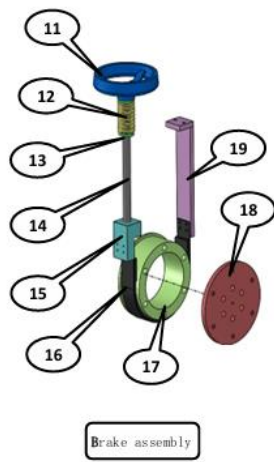
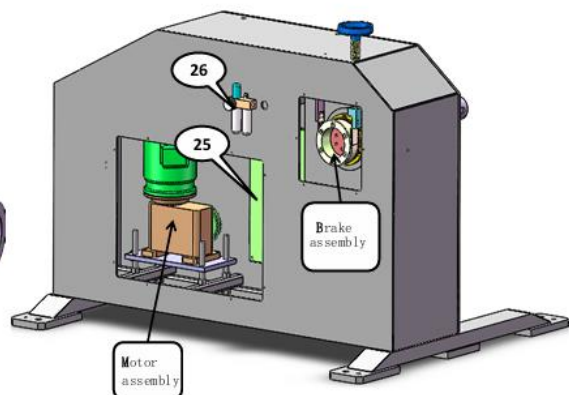
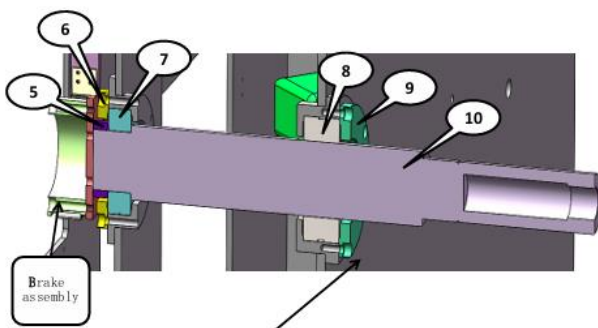
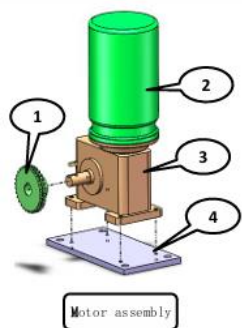

Item	Number/Name
1	BML-00-11010 Drive sprocket
2	1.5KW Motor
3	NP02-80-25-1.5KW
4	BML-00-1008 Motor mounting plate
5	BML-00-13017 Rear brake spacer
6	BML-00-11007 Rear bearing cap
7	Spherical roller bearing 23216
8	Spherical roller bearing 23120
9	BML-00-11005 Front bearing cap
10	BML-03-13011 Mandrel
11	BML-00-16007 Plated casting two spokes
12	Spring (19-35-60)
13	BML-00-16003 Gasket
14	BML-00-16002 Screw
15	BML-00-16004 Brake tensiometer
16	BML-00-16005A Brake
17	BML-00-16008 Brake disc
18	BML-00-16009 Brake cover
19	BML-00-16006 Brake mount
20	BML-03-11 Frame body
21	BML-03-20011 Straightener Bracket
22	BML-00-41015 Power switch support plate
23	Fuji BW32AG-20A
24	BML-00-41009 Power switch mounting plate
25	BML-00-41007 Electrical mounting plate
26	LXPC200-08 triple combination
27	
28	
29	

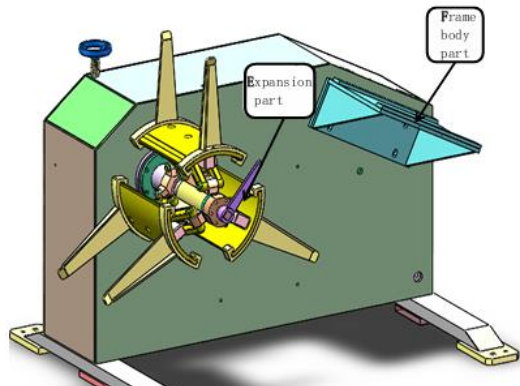
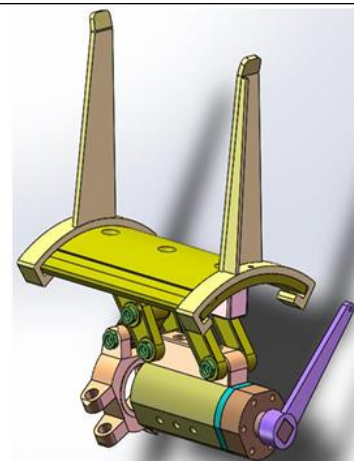
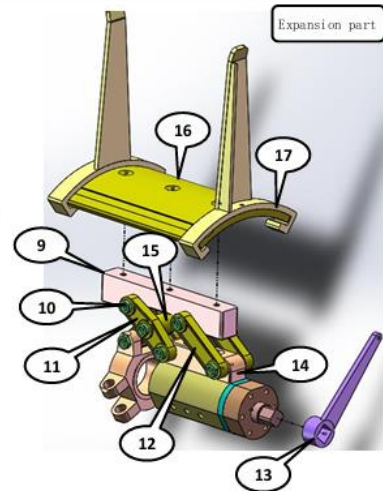
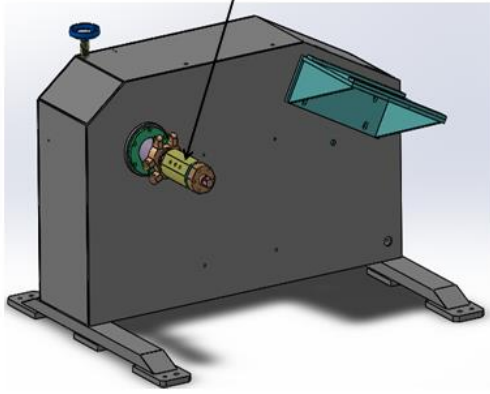
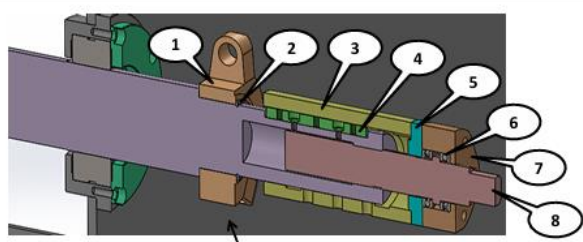

Item	Number/Name
1	BML-00-13013 Expansion back support
2	GB894, 2-86 Shaft circlip B type 80
3	BML-00-13009 Expansion sleeve
4	BML-00-13014 Navigation key
5	BML-00-13010 Front lock ring washer
6	Thrust ball bearing 51109
7	BML-00-13005 Front locking ring
8	BML-00-13004 Front screw
9	BML-03-13002 Expansion board bracket
10	023-00-13009 Plug
11	023-00-13008 Connecting rod (2)
12	023-00-13007 Connecting rod (1)
13	BML-00-13016 Expansion handle
14	BML-00-13003 Hinged plate
15	023-00-13006 Short hinge
16	BML-03-13001 Tile
17	BML-00-13015 A frame
18	
19	

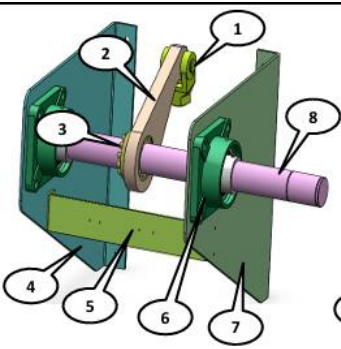

Pressing arm front/rear support plate group

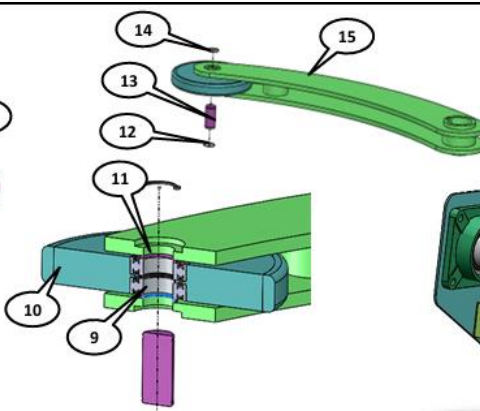

Pressing arm roller group

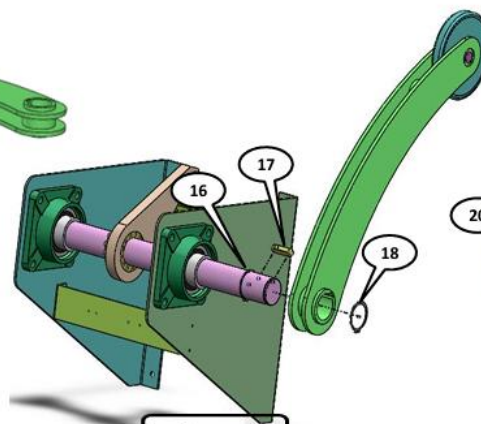

Pressing arm parts

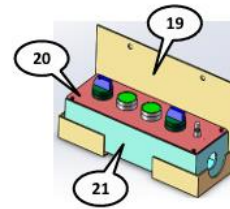

Control box parts

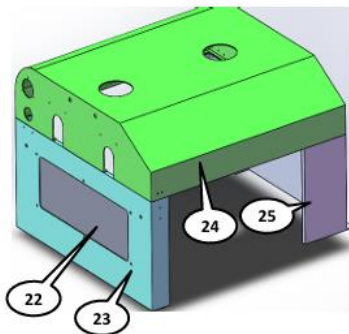

Straightener cover

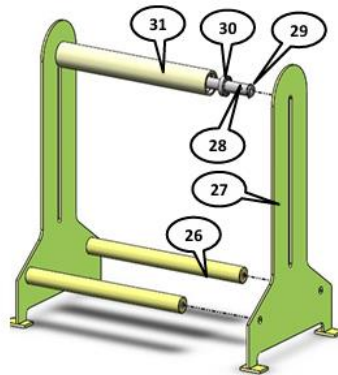

Touch sensor

Item	Number/Name
1	SCS2-125-Y
2	001-03-12006 Pressing arm control lever
3	FT-HE2-28 (60×90×40)
4	BML-00-43007 Pressing arm rear support plate
5	BML-00-43008 Solenoid valve mounting plate
6	Bearing with square seat UCFU212
7	BML-00-43006 Pressing arm front support plate
8	BML-03-12001 brake shaft
9	Deep groove ball bearings 6005-2Z
10	001-00-12004A Pressing arm roller
11	001-00-12005A washer
12	GB894, 2-86 Shaft circlip B type 25
13	001-00-12003A shaft
14	GB894, 2-86 Shaft circlip B type 25
15	001-00-12002A Pressing arm
16	GB894, 2-86 Shaft circlip B type 60
17	GB/T1096-1979 Ordinary flat key type A18×60
18	GB894, 2-86 Shaft circlip B type 60
19	BML-00-40012B control box
20	BML-00-40014B control panel
21	BML-00-40013B control box body
22	BML-00-42001 Perspective window
23	BML-00-42002 Front cover
24	BML-03-42004-A1 Upper cover
25	BML-00-42003 Rear cover
26	BML-03-15002 Touch sensor roller

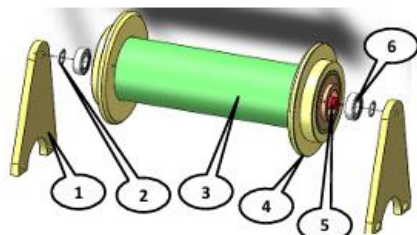

Carrier roller of inlet

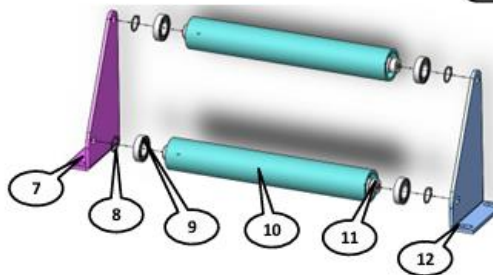

Carrier roller of outlet

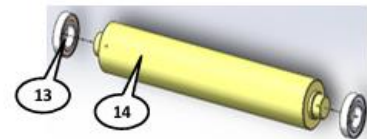

Straightener upper rollers

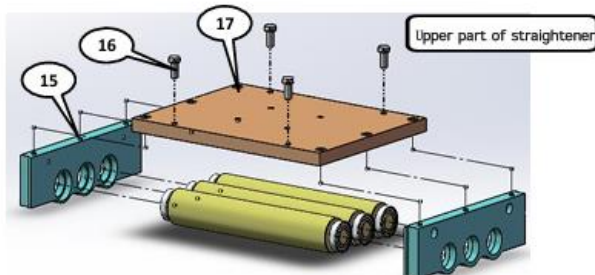

Upper part of straightener

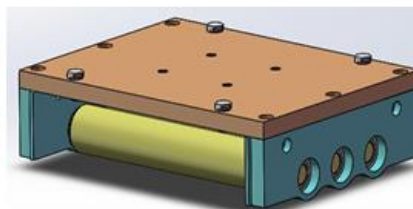
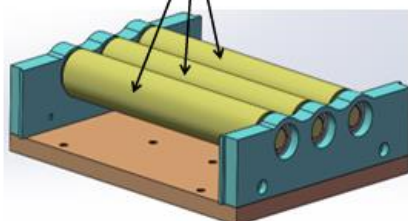

Item	Number/Name
1	BML-00-25021 Left and right baffles
2	GB894, 2-86 Shaft circlip B type 20
3	BML-03-25002 Carrier roller of inlet
4	BML-00-25003 Inlet fixed ring
5	BML-03-25001 Support roller shaft
6	Deep groove ball bearings 6004-2Z
7	BML-00-22004 Outlet guide plate (1)
8	GB894, 2-86 Shaft circlip B type 20
9	Deep groove ball bearings 6901-2Z
10	BML-03-22002 Outlet carrier roller
11	BML-03-22001 Outlet carrier roller axis
12	BML-00-22005 Outlet guide plate (2)
13	Deep groove ball bearings 6005-2Z
14	BML-03-24002 Straightener upper rollers
15	BML-00-24005 Front & rear plate
16	GB/T5781-2008 Hex head bolt C grade M12×35
17	BML-03-24001 Plate
18	
19	
20	
21	
22	
23	

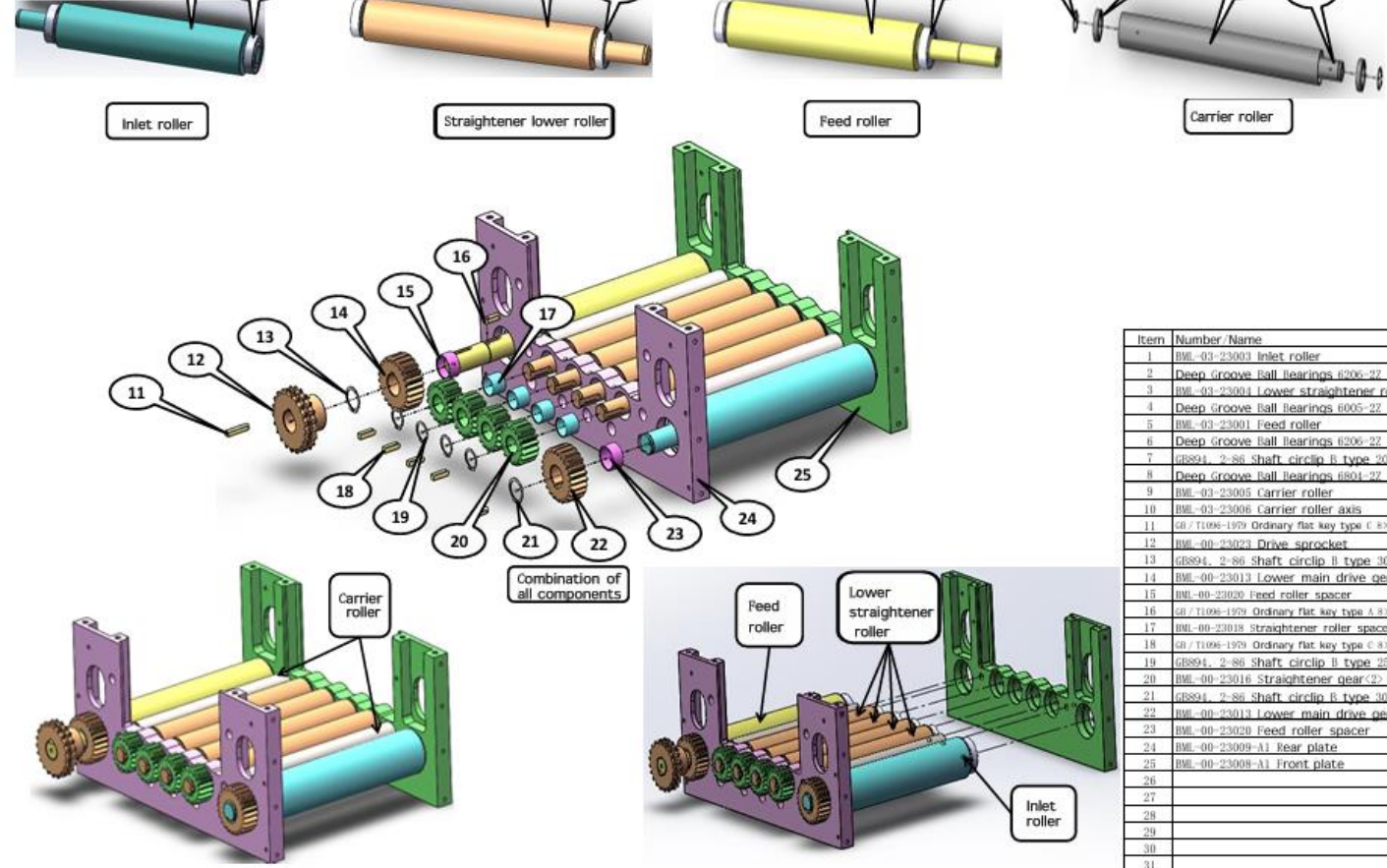

Item	Number/Name
1	BML-03-23003 Inlet roller
2	Deep groove ball bearings 6206-2Z
3	BML-03-23004 Lower straightener roller
4	Deep groove ball bearings 6005-2Z
5	BML-03-23001 Feed roller
6	Deep groove ball bearings 6206-2Z
7	GB894 2-86 Shaft circlip B type 20
8	Deep groove ball bearings 6804-2Z
9	BML-03-23005 Carrier roller
10	BML-03-23006 Carrier roller axis
11	GB/T1098-1979 Ordinary flat key type C 8x40
12	BML-00-23023 Drive sprocket
13	GB894 2-86 Shaft circlip B type 30
14	BML-00-23013 Lower main drive gear
15	BML-00-23026 Feed roller spacer
16	GB/T1098-1979 Ordinary flat key type A 8x28
17	BML-00-23019 Straightener roller spacer
18	GB/T1098-1979 Ordinary flat key type C 8x25
19	GB894 2-86 Shaft circlip B type 25
20	BML-00-23016 Straightener gear
21	GB894 2-86 Shaft circlip B type 30
22	BML-00-23013 Lower main drive gear
23	BML-00-23020 Feed roller spacer
24	BML-00-23009-A1 Rear plate
25	BML-00-23008-A1 Front plate
26	
27	
28	
29	
30	
31	

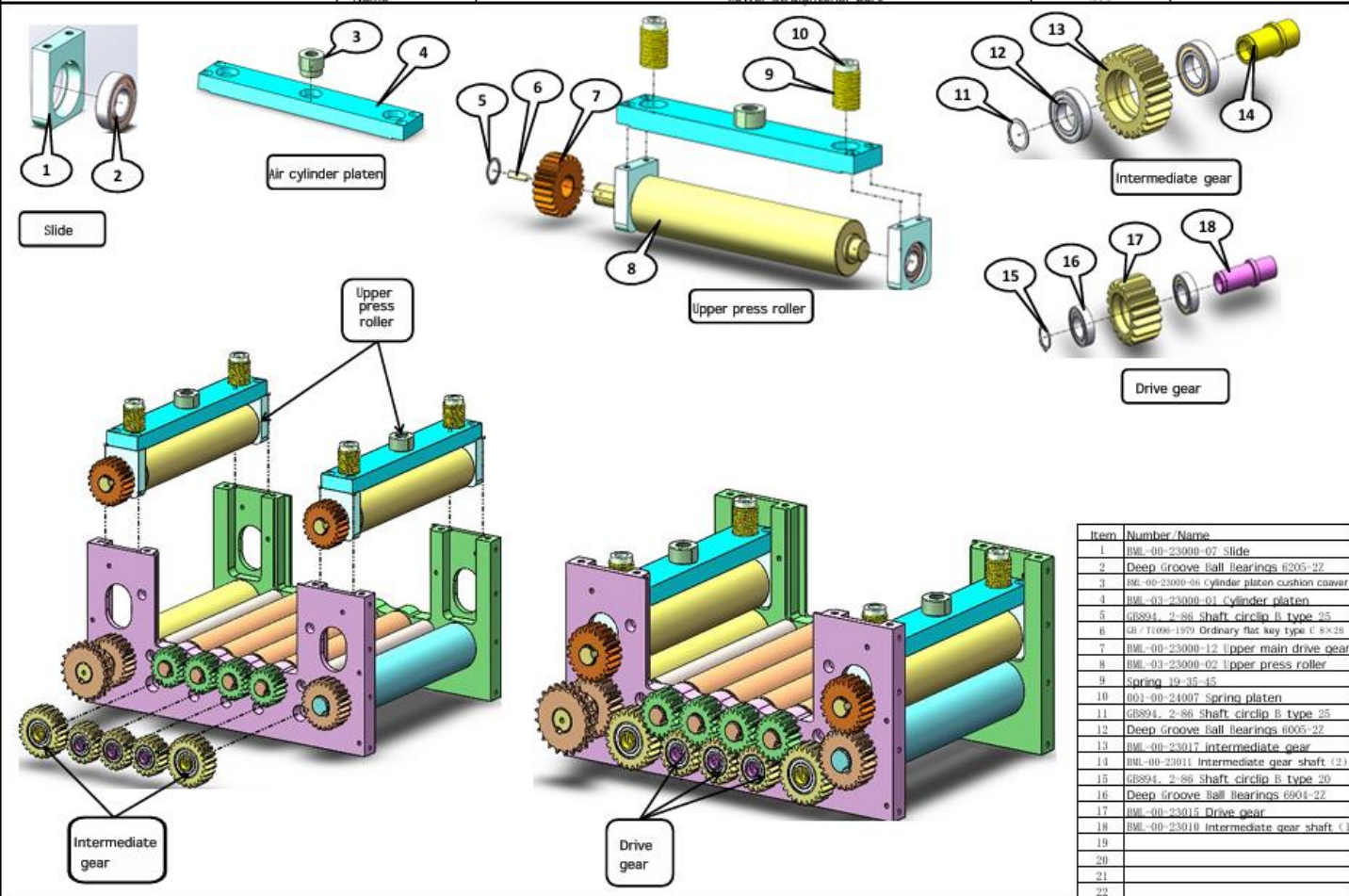

Item	Number/Name
1	BML-00-23000-07 Slide
2	Deep groove ball bearings 6205-2Z
3	BML-00-23009-06 Cylinder platen cushion cover
4	BML-03-23000-01 Cylinder platen
5	GB894 2-86 Shaft circlip B type 25
6	GB/T1098-1979 Ordinary flat key type C 8x28
7	BML-00-23000-12 Upper main drive gear
8	BML-03-23000-02 Upper press roller
9	Spring 19-35-15
10	601-00-24007 Spring platen
11	GB894 2-86 Shaft circlip B type 25
12	Deep Groove Ball Bearings 6005-2Z
13	BML-00-23017 Intermediate gear
14	BML-00-23011 Intermediate gear shaft (2)
15	GB894 2-86 Shaft circlip B type 20
16	Deep groove ball bearings 6904-2Z
17	BML-00-23015 Drive gear
18	BML-00-23010 Intermediate gear shaft (1)
19	
20	
21	
22	

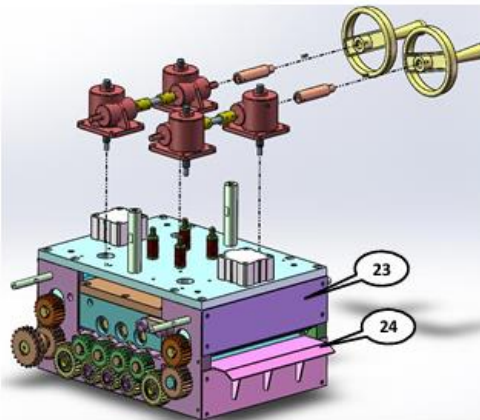
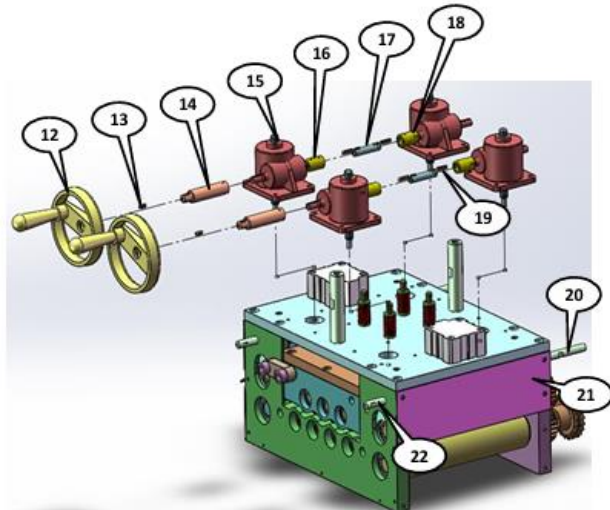
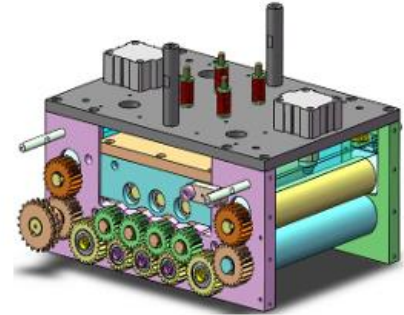
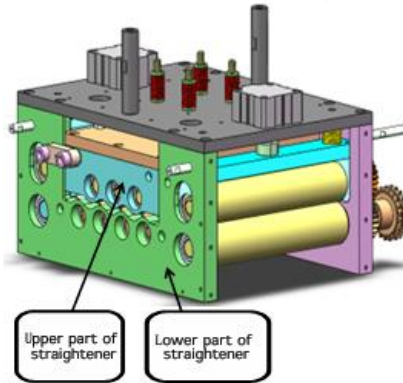
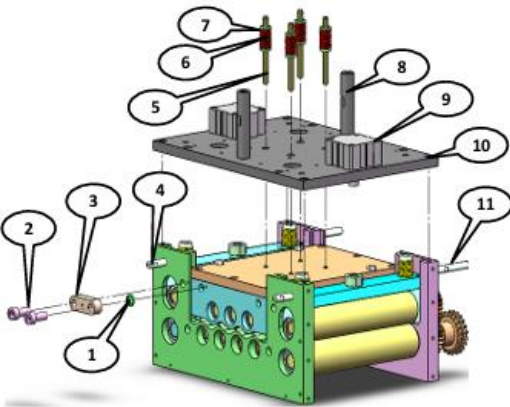

Item	Number / Name
1	HWL-00-20010 Pin Spacer
2	HWL-00-20009 Connect the fixed block pin
3	HWL-00-20008 Fixed block for connect
4	BWL-00-20026 Guard strut (2)
5	HWL-00-20028 Screw of raise
6	Spring 13-25-40
7	BWL-00-20027 Spring washer
8	HWL-00-20035 Ring rod
9	SDA80-108
10	BWL-03-20001 Top plate of upper press roller
11	BWL-00-20025 Guard strut (1)
12	Two-spoke handle YETP.1604-16
13	GB / T1096-1979 Ordinary flat key type C 5X16
14	HWL-00-20000 Handwheel connection rod
15	Screw HPL (SPL) 10X
16	HWL-00-20006 Form fixing sleeve
17	BWL-03-20007 Turbine connection rod
18	HWL-00-20006 Form fixing sleeve
19	GB / T1096-1979 Ordinary flat key type C
20	HWL-00-20025 Guard strut (1)
21	BWL-03-42006 Outlet sealing plate
22	BWL-00-20026 Guard strut (2)
23	BWL-03-42001 Inlet sealing plate
24	BWL-03-42005 Inlet guide plate
25	
26	
27	



Presses & Automation

SINCE 1975

www.azimuthpress.com



Feed-line

We excel in providing turnkey solutions with our custom servo feeding systems, designed to accommodate a wide range of materials—from thin sheets to automotive-grade thicknesses. Our dedicated approach ensures that each system is tailored to meet your specific production requirements, enhancing efficiency and performance.

Turn-key solution

At Azimuth, we specialize in creating customized production lines tailored to your exact specifications. Simply send us your part drawings, and our experienced team will develop a solution designed to maximize efficiency and elevate performance across your operations. As part of our commitment to quality, we'll rigorously test and run your production setup before shipment, ensuring flawless installation and seamless integration when it reaches you.



We are committed to delivering high-quality, innovative automation solutions tailored specifically for the stamping industry. Our UL certification underscores our dedication to safety and excellence, ensuring that our custom-built systems meet the highest industry standards.