

FIRST POSITION

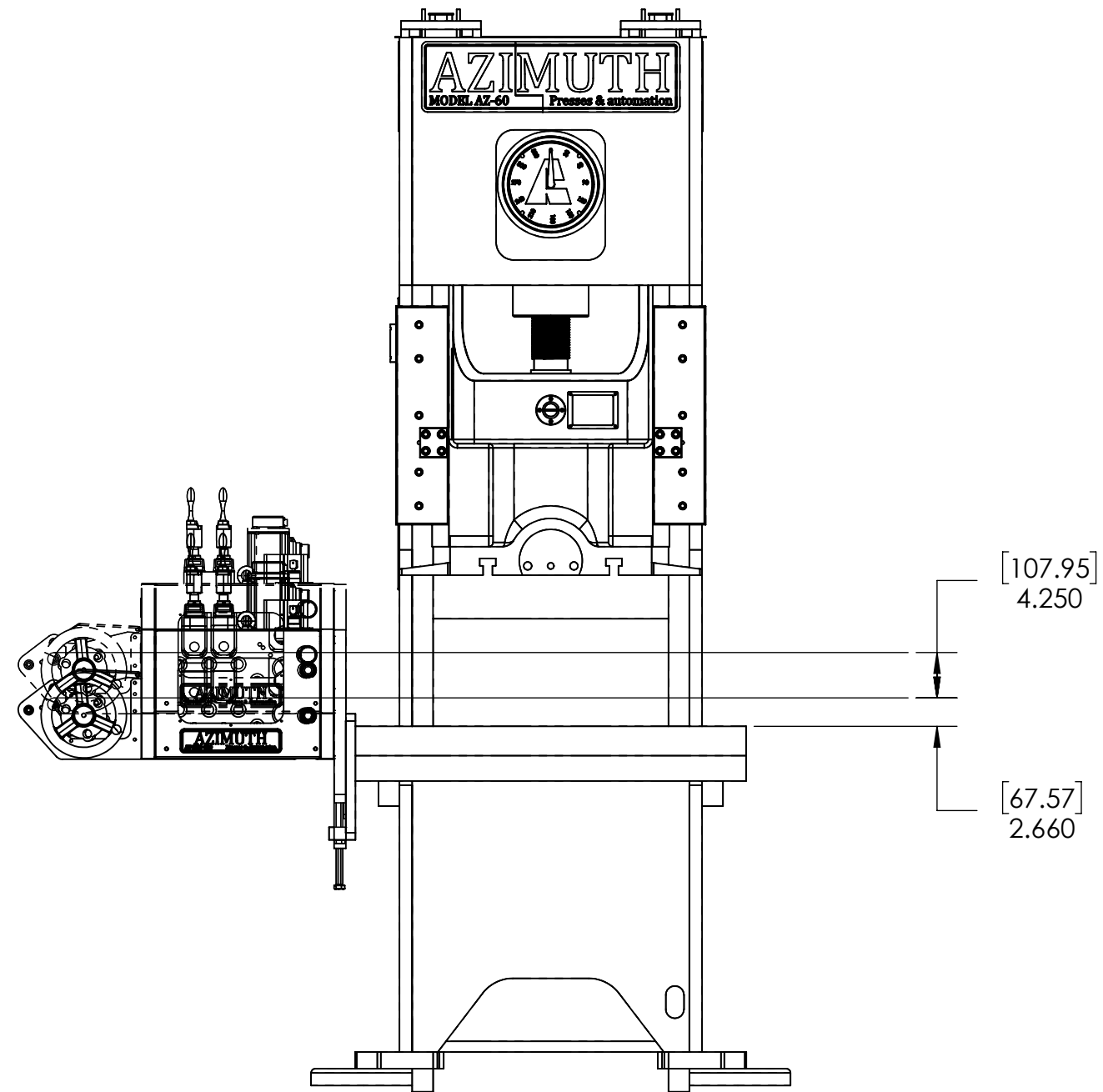

SECOND POSITION

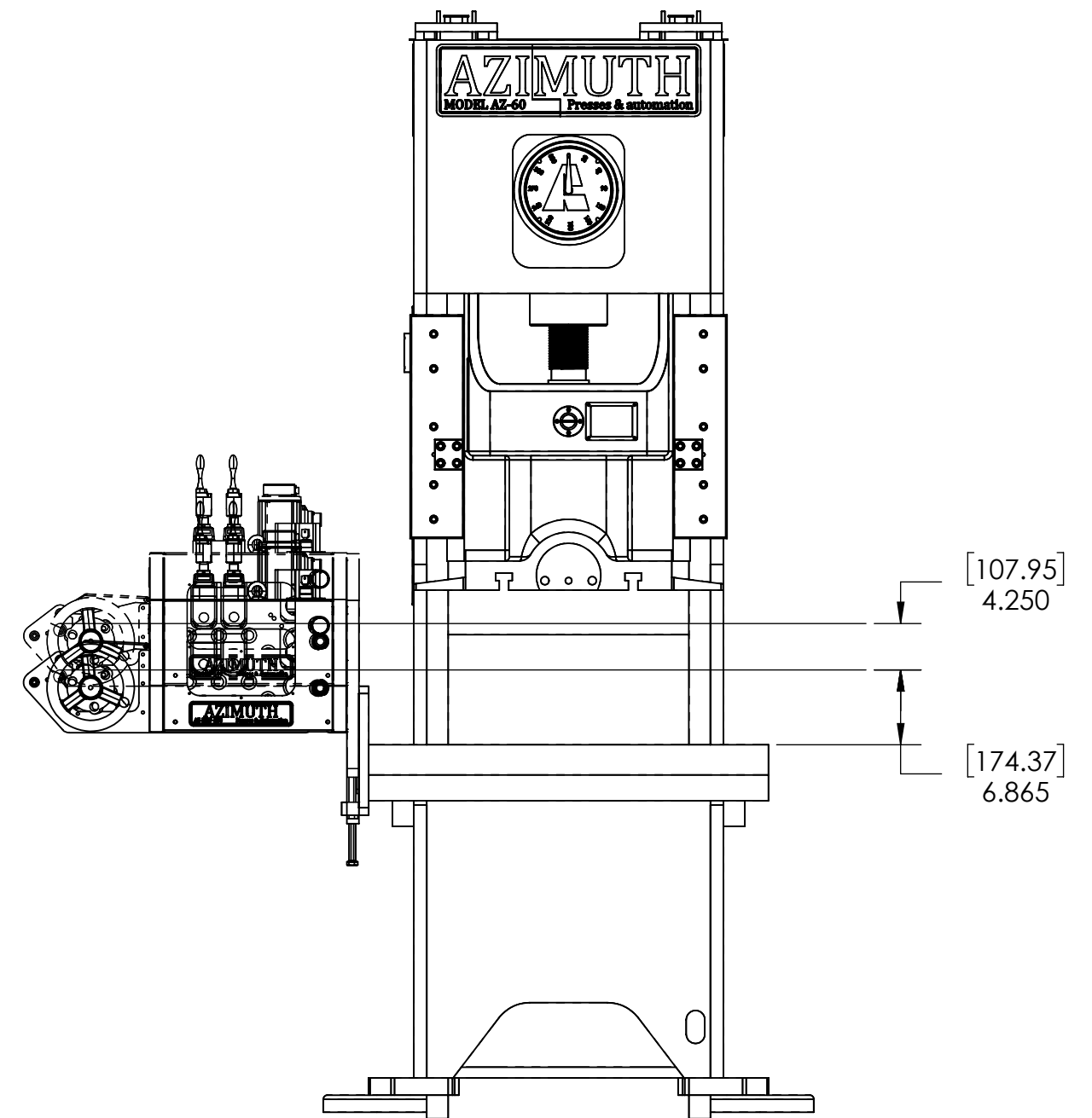

REVISIONS

REV.	DESCRIPTION	DATE	APPROVED
------	-------------	------	----------

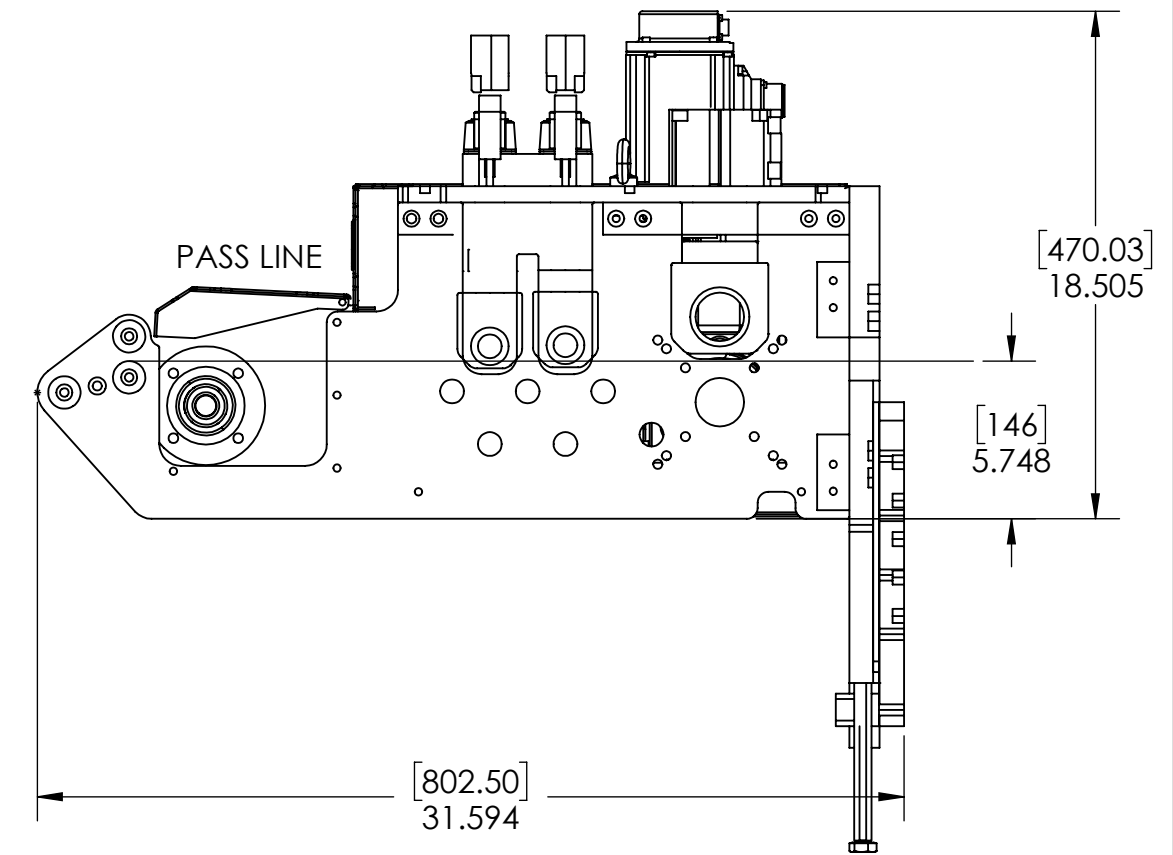
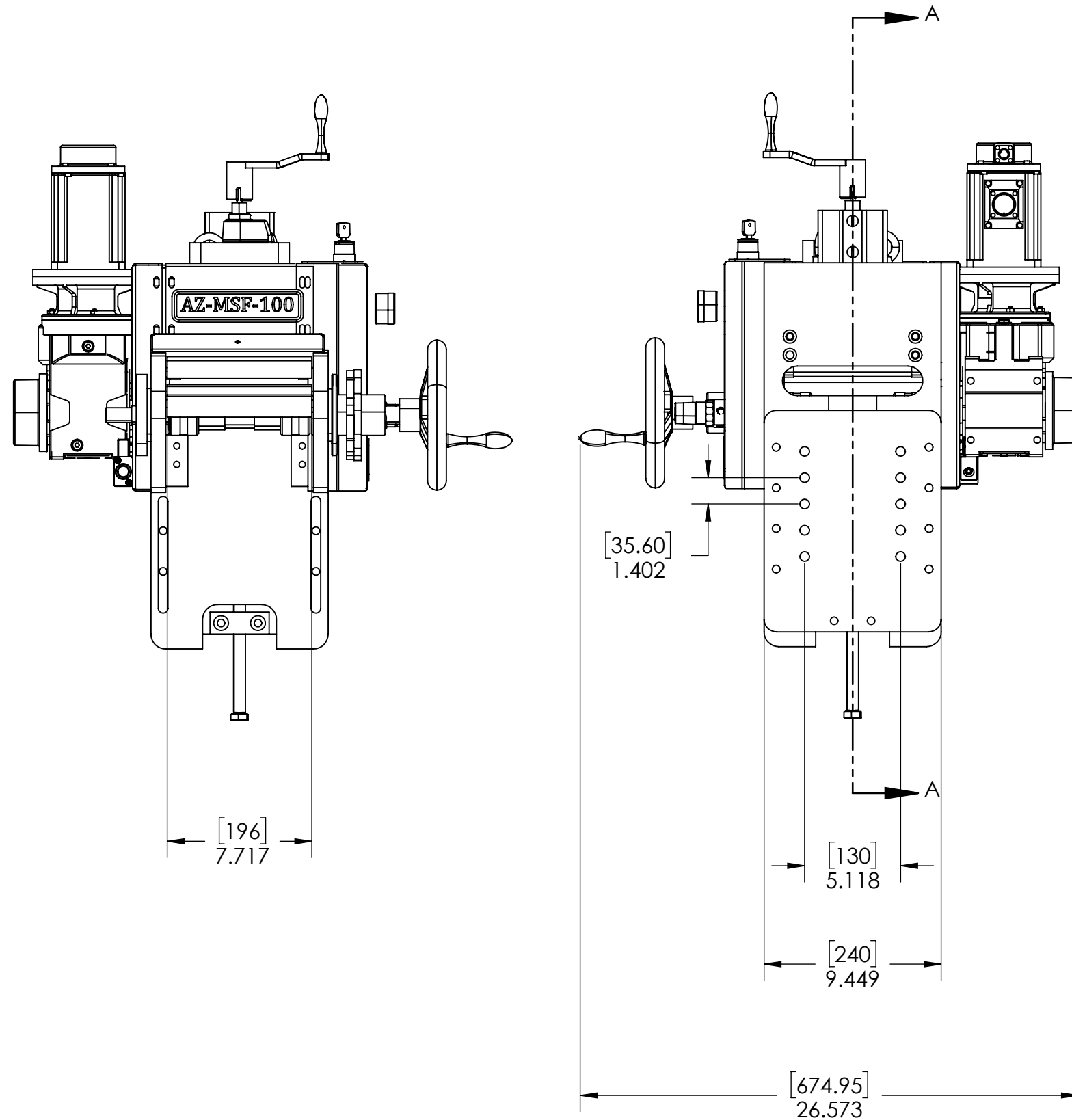

SECTION A-A

NOTE : BREAK ALL SHARP EDGES

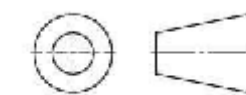

DIMENSIONS ARE IN INCHES
 TOLERANCES :
 ANGLES : ±1°
 FRACTIONAL ±1/32
 TWO PLACE DECIMAL ±.01
 THREE PLACE DECIMAL ±.005
 FOUR PLACE DECIMAL ±.001

DESCRIPTION	
VUE DE PRESENTATION	
PART NO	
AZ-MSF-100-0000-00	
DRAWN BY	SCALE
ALICE DENIS	1:7
DATE	MATERIAL
3/12/2024	
RAW MATERIAL	QTY
TREATMENT	WEIGHT

Azimuth Machinery Inc
 T 450 532 8080
 F 450 532 8081
 www.azimuthpress.com
 6042 Rte. 132, Ste-Catherine
 QC, Canada, J5C 1K6

PROPRIETARY AND CONFIDENTIAL
 THE INFORMATION CONTAINED IN THIS DRAWING IS THE SOLE PROPERTY OF AZIMUTH MACHINERY. ANY REPRODUCTION IN PART OR AS A WHOLE WITHOUT THE WRITTEN PERMISSION OF AZIMUTH MACHINERY IS PROHIBITED.