



Presses & Automation – Since 1975

Instruction Manual for AZ1 & AZ2 models





AZIMUTH MACHINERY
T. 450 632 8080 • sales@azimuthpress.com • www.azimuthpress.com
6040 Route 132, Ste-Catherine, Quebec, Canada, J5C 1B6



*Instruction Manual for AZ1
& AZ2 models*



1. Importance of operating manual

This manual is written in order to become familiar with all the functions and possible applications of our machine. It contains important instruction about how to use the machine safely; according to the purpose designated.

Following these instructions is not only essential to avoid risks. It also reduces repair costs and down-time and increases the products reliability and service-life. Anyone who works with the machine should follow the instructions in this manual, particularly the safety related instructions.

Additionally local rules and regulations relating to environmental safety and accident prevention may be applied.

2. User-responsibility

Only allow persons to work with the machine who are familiar with the general instructions on how to work safely and to prevent accidents. The use of the instrument should have been instructed duly *THE SAFETY Chapter* and the warnings in this manual should have been read and understood.

3. Responsibility of operator

Before commencing work anyone appointed to work with the machine should pay attention to the general regulations to working safety and accident prevention. The safety chapter and the warnings in this manual should have been read and understood.

4. Dangers

This machine is designed and manufactured according to advanced technical standards and recognized safety regulations. However, improper use of the machine for work may result in a danger to the life and health of the operator or others, or damage to the machine or other property. Therefore the machine should only be used for its designated purpose, and in a perfect technical condition, Any defect that could have a negative effect on safety should be repaired immediately.

5. Designated purpose

The ***electronically controlled program of Azimuth machines*** is specially designed for pressing and riveting sheets of various materials.

AZIMUTH will not be held liable for damage resulting from improper use. Designated purpose also includes properly observing all instructions in the operation manual, and adherence to inspection and maintenance schedules.

6. Copyright

The copyright of this operating manual remains with AZIMUTH MACHINERY.

This operating manual is intended solely for the user and his personnel. Infringement of this restriction may lead to legal action may be taken if this restriction is infringed upon



AZIMUTH MACHINERY
T. 450 632 8080 • sales@azimuthpress.com • www.azimuthpress.com
6040 Route 132, Ste-Catherine, Quebec, Canada, J5C 1B6



7. Manufacturer's & Supplier's address

Adresse : 6040 QC-132, Sainte-Catherine, QC J5C 1B6
Téléphone : (450) 632-8080
Province : Québec
Country : CANADA
SALES@AZIMUTHPRESS.COM
<https://azimuthpress.com/>



Table of Contents

1.SPECIFICATION (AZ1 & AZ2)	6
Dimension of bolster and slide AZ1	7
Bed dimension	8
Specification Table AZ1 (Dimensions, weight)	9
Counter balance Settings	11
Rated tonnage graph	12
Press layout AZ1	13
Press capacity curve AZ2	21
Press layout AZ2	23
2.Safety instruction & Instrument Preparation	25
2.1 Safety precautions	25
2.1.1 Start-up inspection	26
3.Transport and Installation	30
3.1 Acceptance inspection	30
3.2 Carrying	31
3.2.3 Lifting procedures:.....	31
Disassembly	32
3.3 Installation	33
Installation of frame and bolster	33
Leveling	34
Main motor installation	35
Oil filling requirement.....	37
Air connection.....	39
Installation & START-UP Functional diagram	40
Oil quantity	41
Air lines system	42
Main components and Function (AZ1 & AZ2)	44
Main components – AZ1	44
Main components – AZ2	45
Maintenance	47
Mechanical Set-up.....	47
Adjusting the Shut Height	47



Ram and Gibs Maintenance	48
Cleaning the Ram Contact Surfaces	48
Checking Gibs Clearance	49
Adjusting Gibs Clearance	50
Checking Ram and Bed Parallelism	51
Checking Main bushing clearance & ball-screw clearance	52
Adjusting Belt Tension	53
Hydraulic Overload protection (HOLP).....	54
Adjusting the hydraulic overload	55
Wet-clutch assembly	56
Balance cylinder	58
Changing oil.....	61
Air diagram	70
.....	70
Operating the Press	71
Using the Operator Station	71
Using the Auxiliary and Optional Equipment	72
Automatic Oiling System.....	72
Automatic centralized greasing system	73
Bleeding the Automatic Greasing System.....	73
Light Curtains (Optional).....	76
TROUBLESHOOTING	77
Annexe A - PARTS.....	79
Annexe B – Yearly Maintenance check	84
MAIN BUSHINGS & OVERALL CLEARANCE	85
AIR-CLUTCH & BRAKE	86
OILING SYSTEM for counter balance*.....	88
PRESS OVERALL GUARDING	89
Bolster plate.....	89
Die height adjustment (motorized)	89
Main motor drive.....	89
Warranty plan on part-revolution presses model 6-AC TO 44-AC, AZ1 MODELS, AZ2 MODELS, AZ-S1 MODELS, AZ-S2 MODELS.....	92
Years on air-clutch & electrical components	92



Years mechanical parts warranty..... 92

Year warranty on Hydraulic & others air-components92

1.SPECIFICATION (AZ1 & AZ2)

1.1.1 Press dimension **AZ1 (60 to 340)**

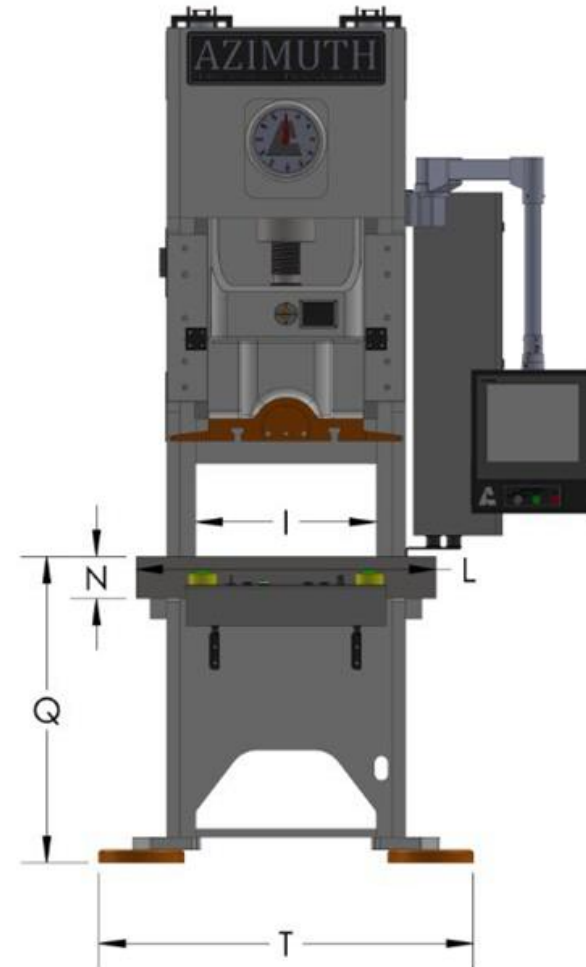
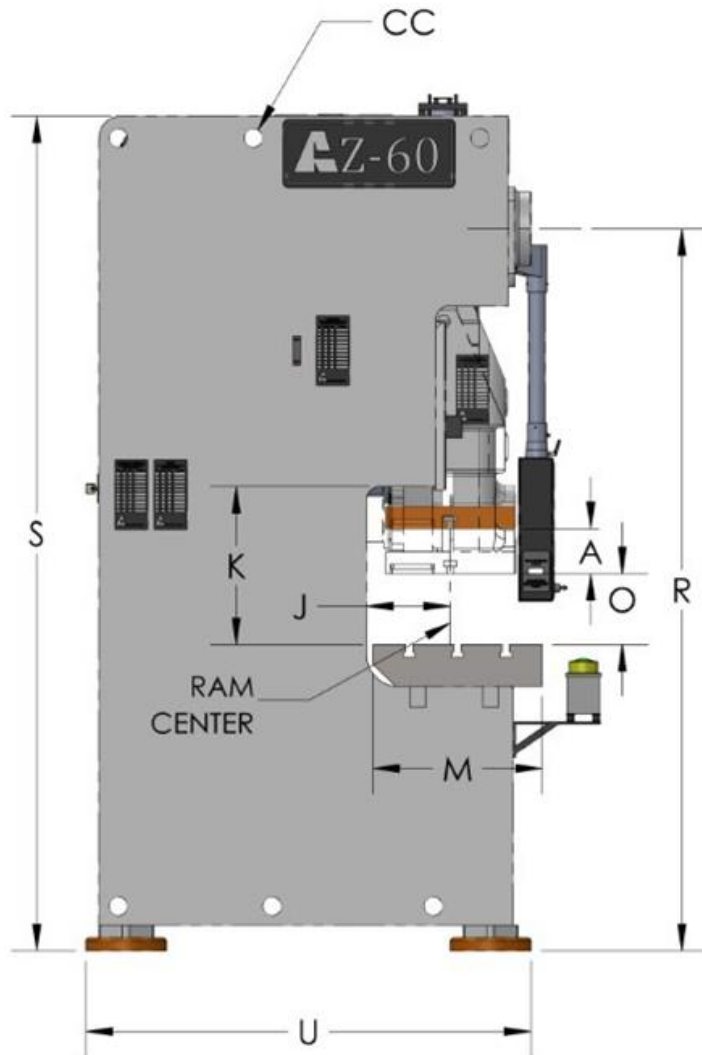



Dimension of bolster and slide **AZ1**

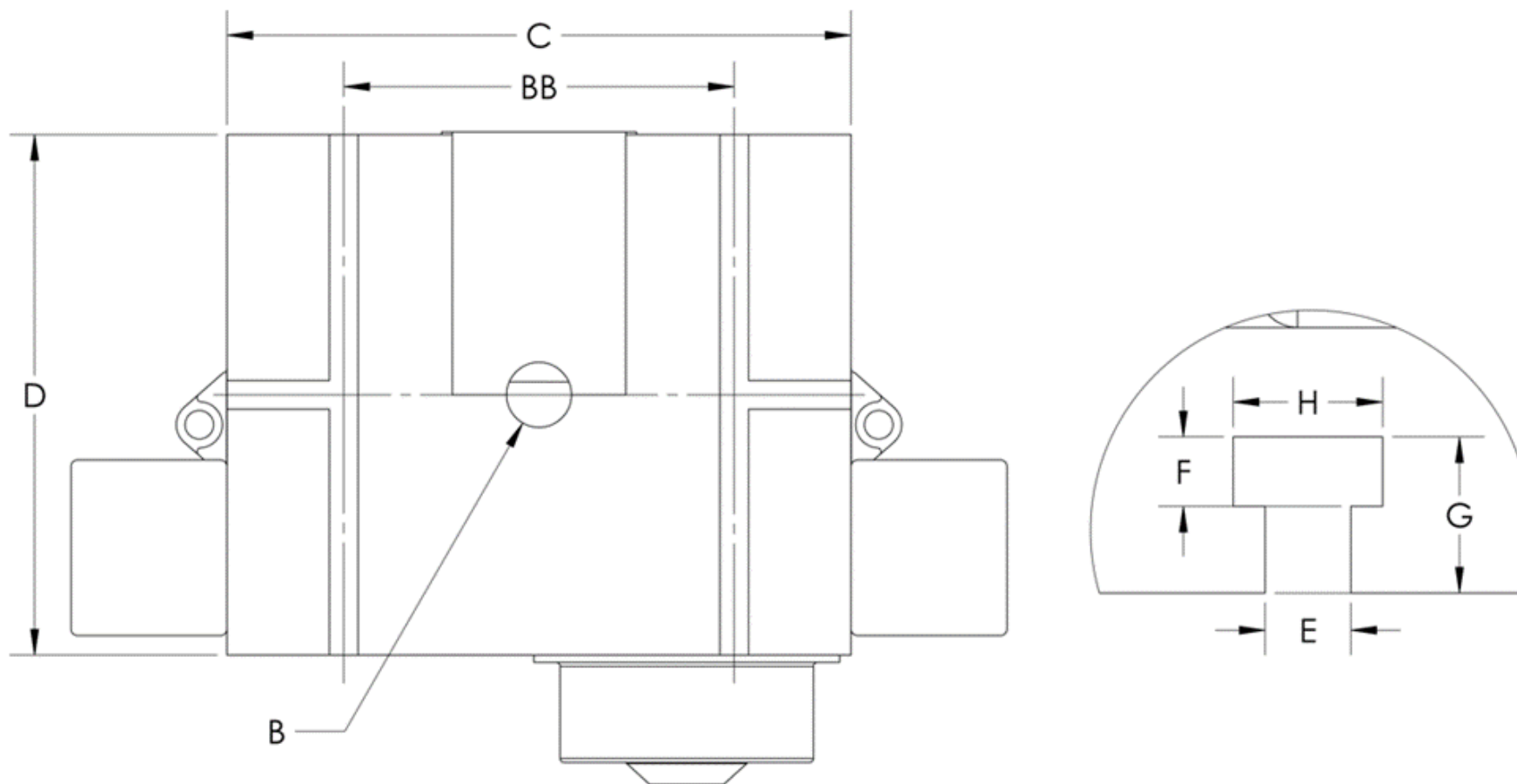

FIGURE 1 - RAM DIMENSION



Bed dimension

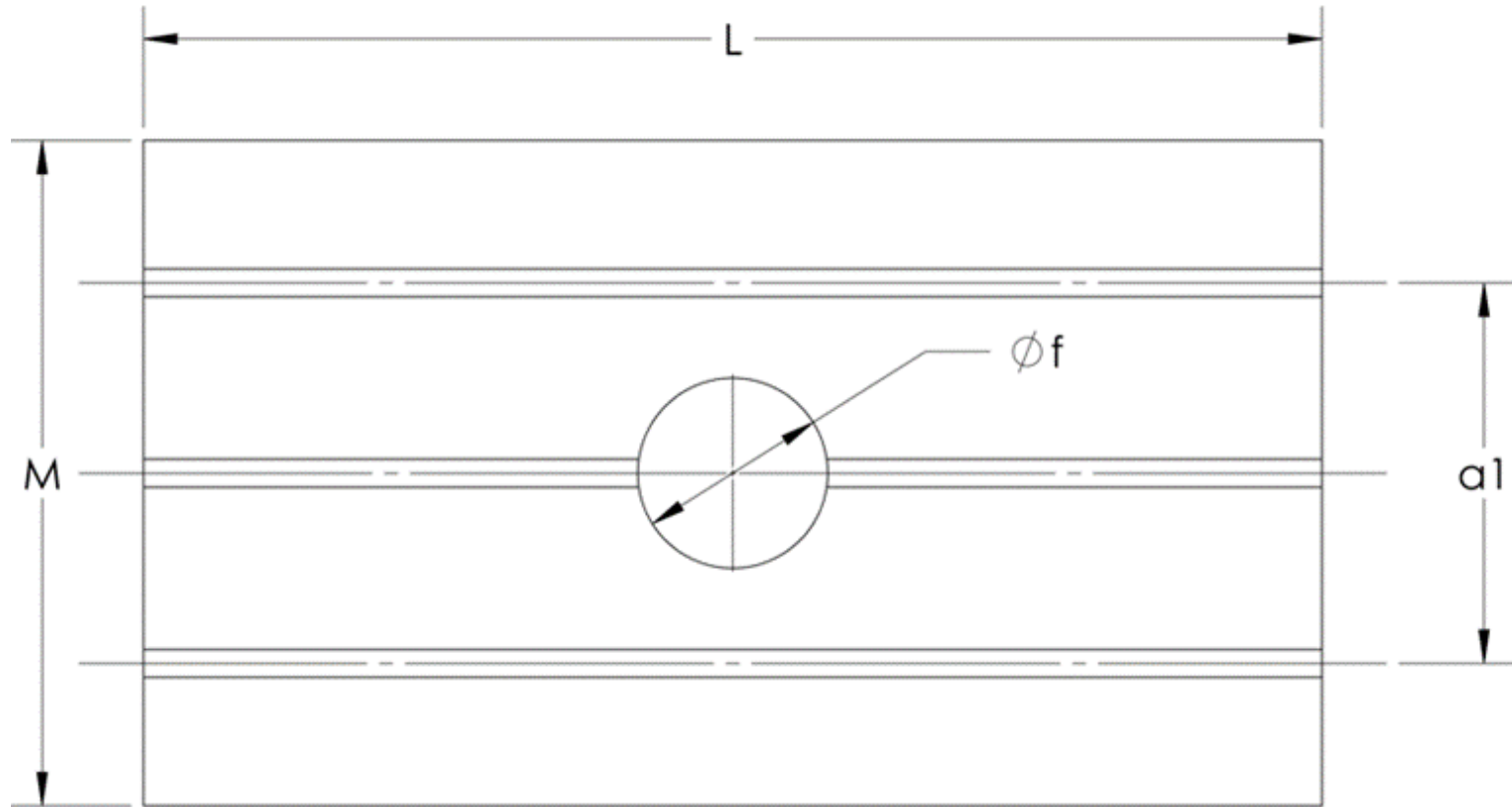

FIGURE 2 - BED DIMENSION

Figure 1.1.2 AZ1 Press Bed Dimensions



Parameter	AZ1-60		A1-280		AZ1-110		AZ1-140			
	S	L	S	L	S	L	S	L		
Type	S	L	S	L	S	L	S	L		
Nominal Capacity	66		88		110		140			
Rated at BDC	0.157		0.197				0.236			
Slide Stroke	A	3.150	5.512	3.937	6.299	3.937	6.299	4.331	7.087	
SPM RANGE	60 - 115		45 - 85		55 - 100		40 - 75		55 - 100	
MAX. Die Height	12.992		11.811		13.780		12.598		14.370	
Height Adjustment	2.756		3.150		3.543					
MIN. Die Height	O	10.236	9.055	10.630	12.598	10.827	9.646	11.614	10.236	
Throat Depth	J	10.630		12.250		12.875		13.750		
RAM	C	18.875		21.250		24.375				
	D	15.750		18.125		20.375				
	B	1.97				2.36				
BED	L	36.625		37.375		41.750		43.250		
	M	20.500		23.625		25.125		26.750		
	f	7.09				8.66				
T-SLOTS	E			0.866						
	F			0.669						
	G			1.496						
	H			1.496						
Floor to Bed	Q			35.5						
Overall	U	62		70		80				
	T	48				56				
	S	102		110		120		125		
Weight (lbs)	11354		14220		19070		21054			



Parameter		AZ1-175		AZ1-200		AZ1-250		AZ1-340	
Type		S	L	S	L	S	L	S	L
Nominal Capacity		175		220		275		340	
Rated at BDC		0.236				0.256		0.276	
Slide Stroke	A	5.118	7.874	5.906	8.661	6.299	8.661	6.299	8.661
SPM RANGE		35 - 70	30 - 55	35 - 65	30 - 55	30 - 55	20 - 35	30 - 55	20 - 35
MAX. Die Height	O	17.126	15.748	19.094	17.717	20.866	19.685	20.866	25.591
Height Adjustment		3.937		4.331		4.724			
MIN. Die Height	O	13.189	11.811	14.764	13.386	16.142	14.961	16.142	20.866
Throat Depth	J	15.750		16.875		17.700			
RAM	C	27.500		34.625		37.375			
	D	22.875		25.500		27.500			
	B	2.56				2.76			
BED	L	46.063		54.750		59.063		60.625	
	M	29.875		33.063		34.625			
	f	10.24				11.02			
T-SLOTS	E	1.10							
	F	0.87							
	G	1.89							
	H	1.89							
Floor to Bed	Q	35.5		39.4					
Overall	U	92		105		110		115	
	T	60		70		70		80	
	S	136		150		160		170	
Weight (lbs)		29983		42329		51147		58643	



The graph **Error! Reference source not found.** indicates the required air pressure, in PSI, in function of the upper die weight, in lbs. This ensures that there will be no clutch slippage due to low air pressure during the cycle.

The air pressure can be adjusted from the provided FRL by turning the valve knob.

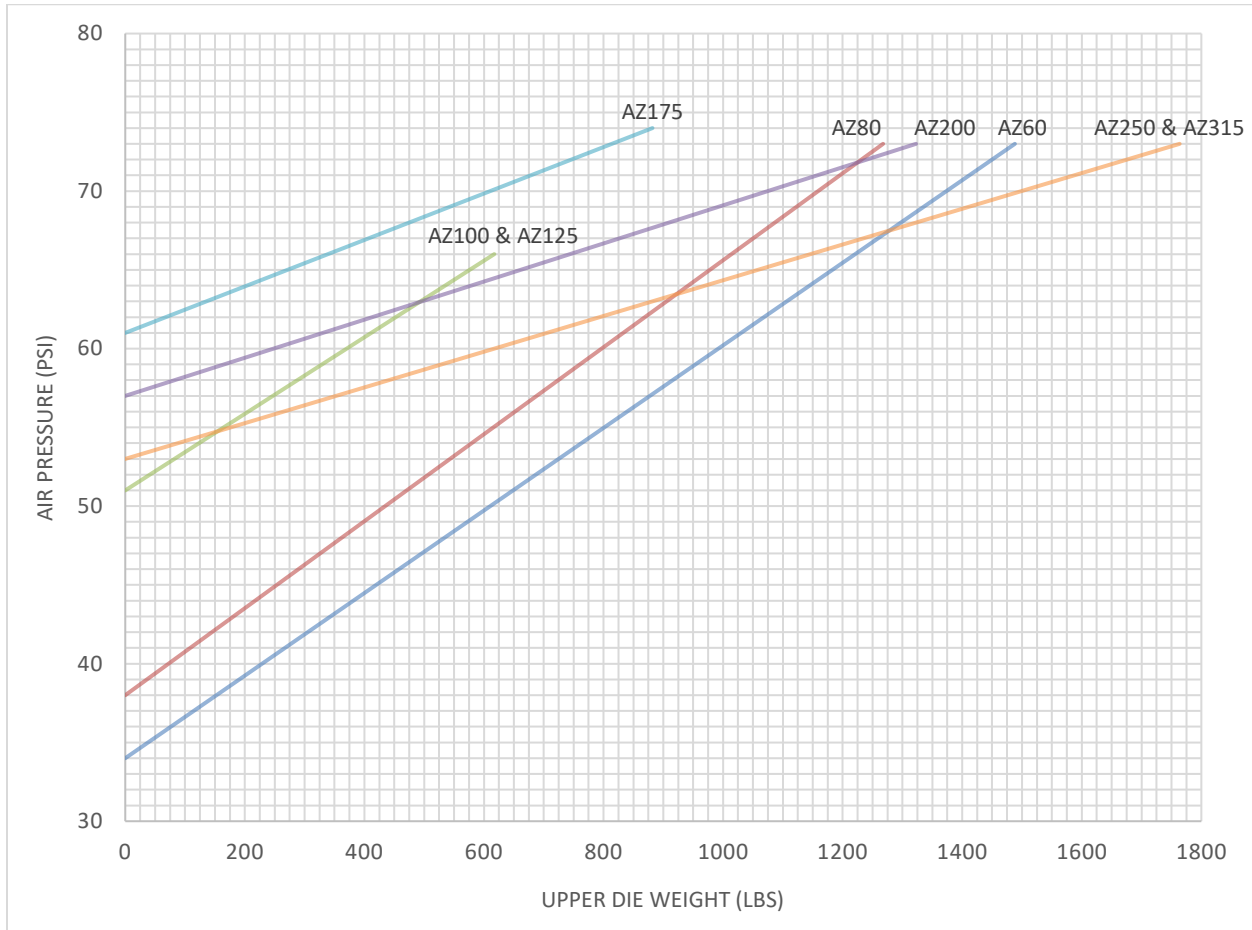

FIGURE 3 - COUNTERBALANCE PRESSURE CHART



The graphs **Error! Reference source not found.** show the capacity of AZ1 presses, in kilonewtons, in function of the distance from bottom dead center. This is useful to determine the pressing capacity for a given material thickness.

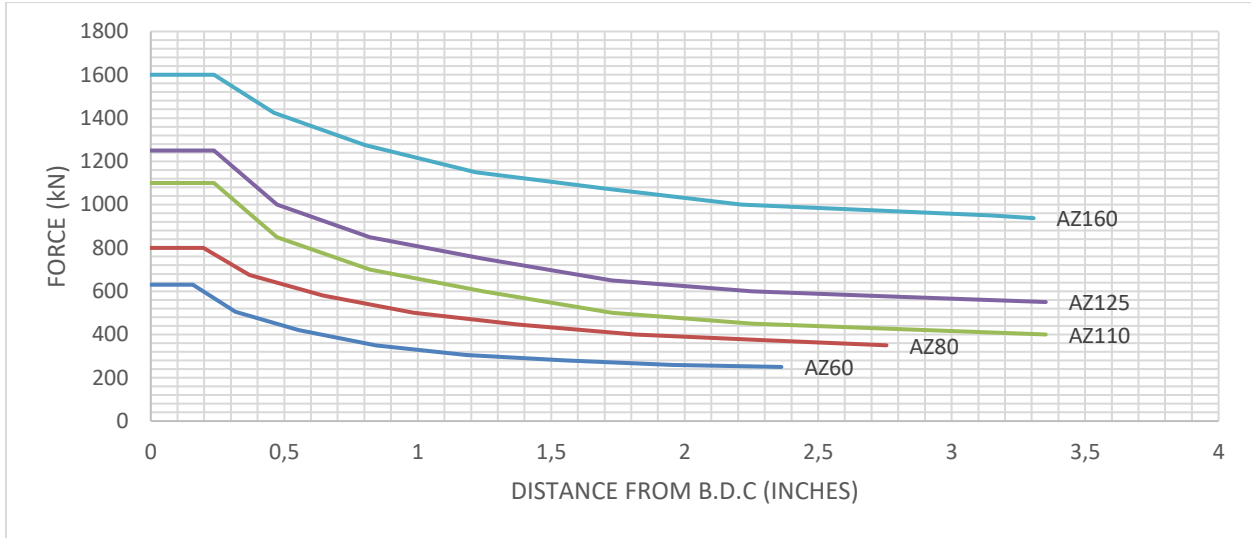

FIGURE 4 - RATED TONNAGE FROM BDC

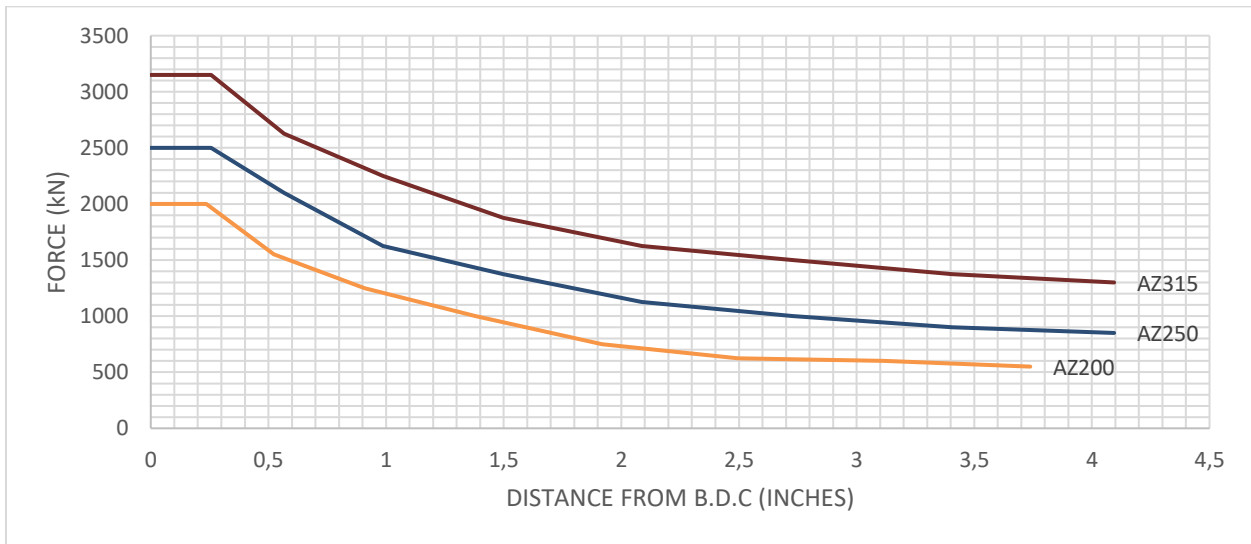

FIGURE 5 - RATED TONNAGE FROM BDC



Figure 1.1.5 Azimuth **AZ1** Assemblage

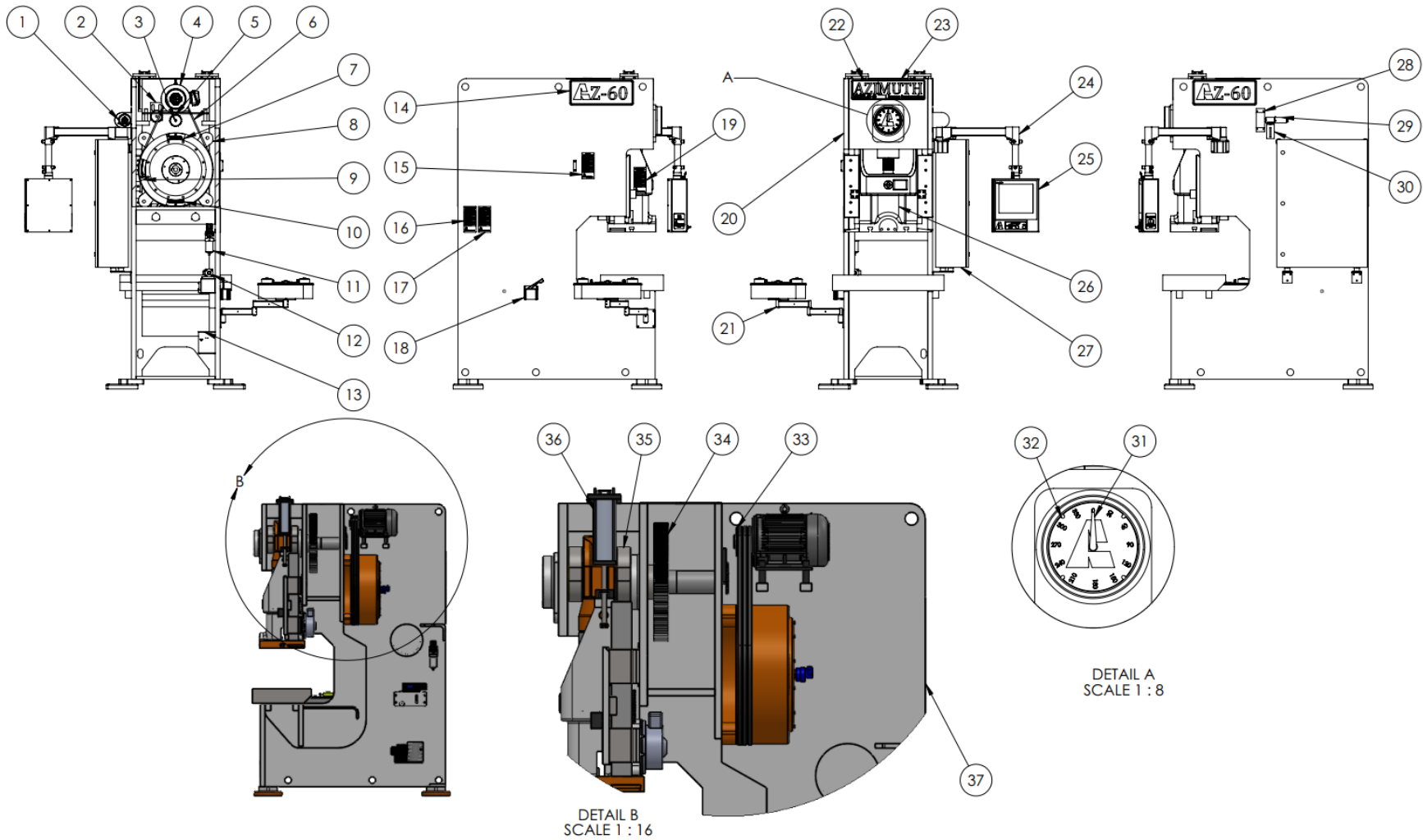



Table 1.1.5 Azimuth AZ1 BOM

ITEM NO.	PART NUMBER	DESCRIPTION
1	69.3	ENCODER SPROCKET
2	260	ENCODER SPROCKET BRACKET
3	233.1	CLUTCH TO SPROCKET SHAFT
4	MTCP2-005-3BD18C	ELECTRIC MOTOR
5	250	ENCODER SPROCKET
6	124	MOTOR CLUTCH BELT
7	410.3	OIL INLET ID
8	200AS	CLUTCH
9	410.6	WETCLUTCH OIL ID
10	410.5	OIL OUTLET ID
11	AW4000-04	FRL
12	1311	OVERLOAD PROTECTOR
13	1312	GREASER
14	410.2	SIDE LOGO
15	410.8	GEARBOX OIL CHANGE ID
16	410.9	OVERLOAD OIL CHANGE ID
17	410.7	CLUTCH OIL CHANGE ID
18	1300-018	MANUAL OILER
19	410.1	WORMGEAR OIL CHANGE ID
20	1	FRAME
21	265AS	DUAL PALM ACTUATOR
22	410.1	FRONT LOGO
23	410.1	FRONT LOGO
24	510AS	SWIVEL ARM
25	502.1AS	SMARTPAC PRO HMI
26	023AS	RAM ASSEMBLY
27	400	ELECTRIC PANEL
28	69.3	SPROCKET COVER
29	69.1	WINTRISS STD RESOLVER
30	69	RESOLVER SUPPORT
31	251.1	ANGULAR POSITION INDICATOR
32	410.4	CADRAN
33	123 Rectangular Snip	ELECTRIC MOTOR PULLEY
34	813	ENGAGING GEAR
35	233AS	AIR CLUTCH CRANKSHAFT
36	810	FAIL SAFE AIR PISTON
37	327	FLY WHEEL GUARD



1.2 Specification **AZ2**



1.2.1 Press dimension AZ2

Figure 1.2.1 AZ2 Press Dimensions

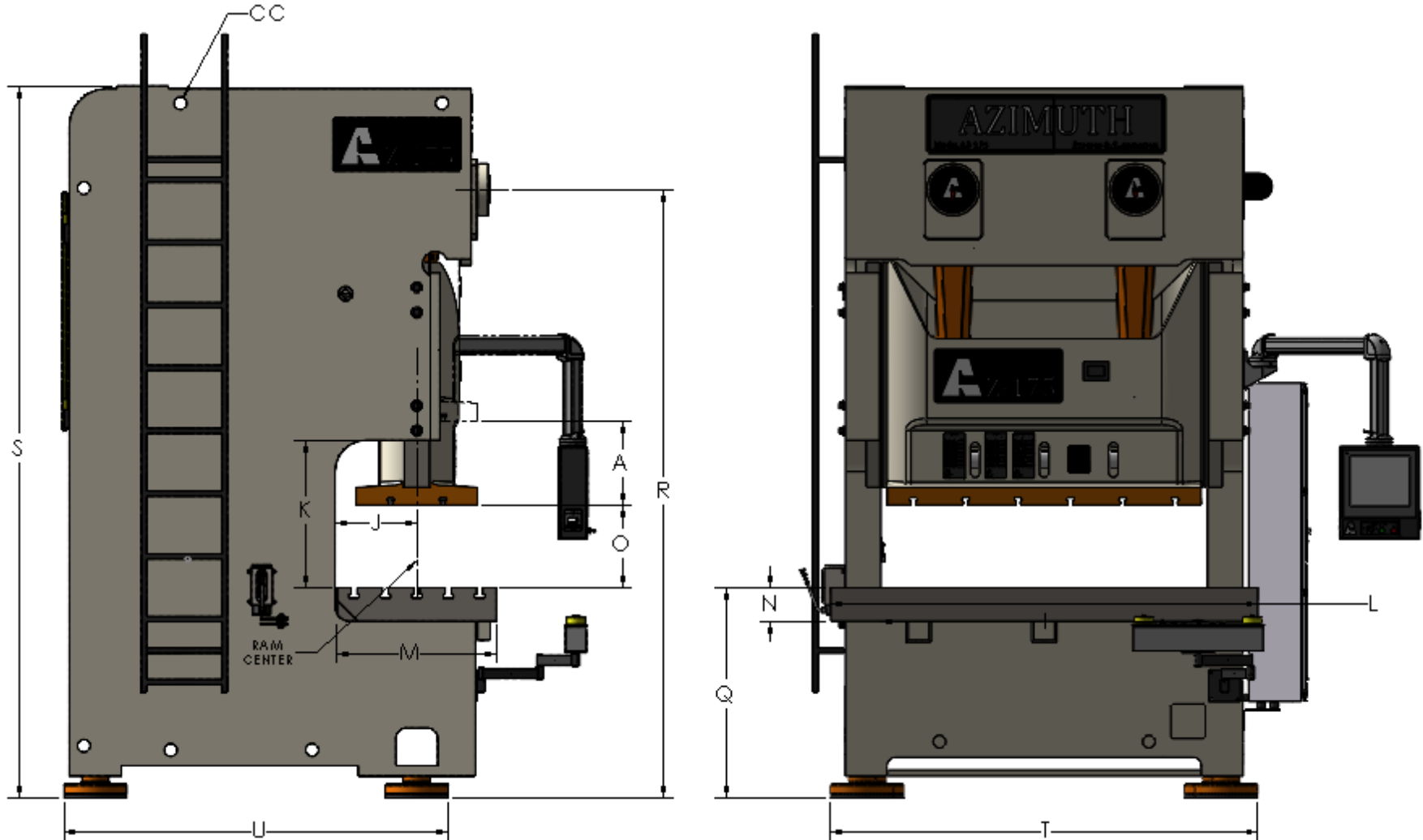



1.2.2 Dimension of bolster and slide **AZ2**

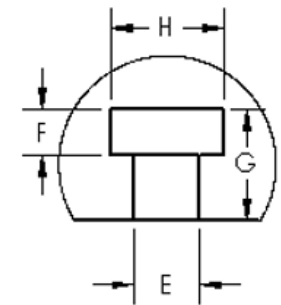
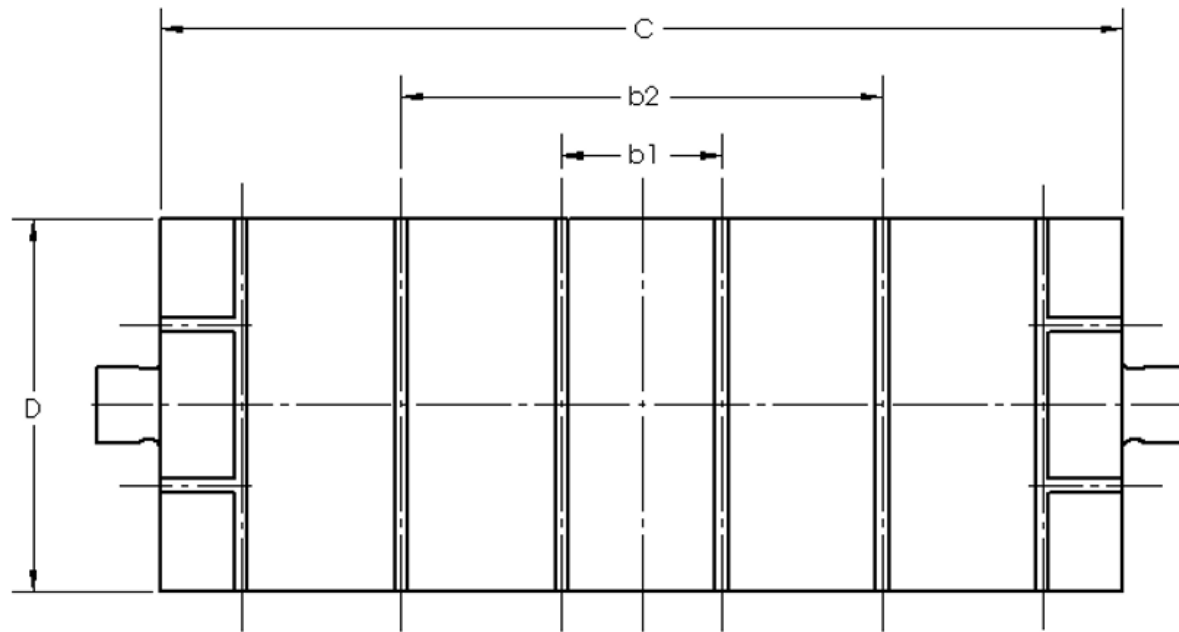

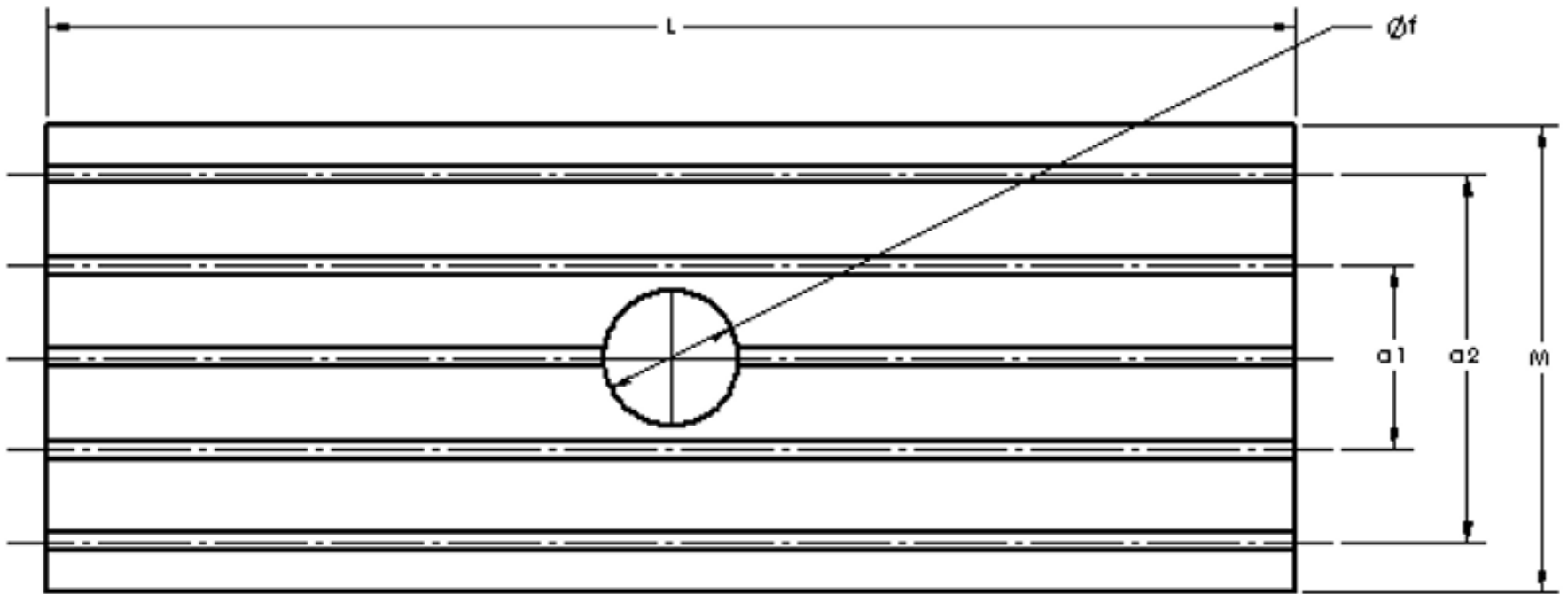



Parameter		AZ2-120		AZ2-175		AZ2-220	
Type		S	L	S	L	S	L
Nominal Capacity		120		175		220	
Rated at thickness		0.197		0.236		0.276	
Slide Stroke	A	4.331	7.087	5.118	7.874	5.906	9.843
SPM RANGE		40-70	35-60	40-70	35-55	30-60	24-40
MAX. Die Height		17.126	15.748	19.094	17.717	21.654	19.685
Height Adjustment		3.543		3.937		4.331	
MIN. Die Height	O	13.583	12.205	15.157	13.780	17.323	15.354
Throat Depth	J	13.750		15.300		16.875	
RAM	C	20.500		22.875		25.500	
	D	55.125		59.063		72.875	
	B						
	L	26.750		29.875		33.000	
BED	M	74.000		80.250		95.250	
	f						
	Q	35.500		35.500		39.375	
Overall	U	71.654		81.890		93.307	
	T	77.559		84.646		100.394	
	S						
Weight (lbs)		30800		41800		58300	



Parameter	AZ2-120		AZ2-175		AZ2-220		AZ2-275		AZ2-340		
	S	L	S	L	S	L	S	L	S	L	
Type											
Nominal Capacity	120		175		220		275		340		
Rated at thickness	0.197		0.236		0.276		0.276				
Slide Stroke	A	4.331	7.087	5.118	7.874	5.906	9.843	6.693	11.024	6.693	11.024
SPM RANGE		40-70	35-60	40-70	35-55	30-60	24-40	30-45	20-35	30-45	20-35
MAX. Die Height		17.126	15.748	19.094	17.717	21.654	19.685	23.819	21.654	23.819	31.654
Height Adjustment		3.543		3.937		4.331		4.724			
MIN. Die Height	O	13.583	12.205	15.157	13.780	17.323	15.354	19.094	16.929	19.094	16.929
Throat Depth	J	13.750		15.300		16.875		18.500		18.875	
RAM	C	20.500		22.875		25.500		27.500			
	D	55.125		59.063		72.875		82.625			
	B										
BED	L	26.750		29.875		33.000		36.250		37.000	
	M	74.000		80.250		95.250		106.300		110.250	
Floor to Bed	Q	35.500		35.500		39.375		43.000			
Overall	U	71.654		81.890		93.307		106.299			
	T	77.559		84.646		100.394		112.205			
	S							164.567			
Weight (lbs)		30800		41800		58300		77000		79200	



Press capacity curve AZ2

The graph **Error! Reference source not found.** indicates the required air pressure, in PSI, in function of the upper die weight, in lbs. This ensures that there will be no clutch slippage due to low air pressure during the cycle.

The air pressure can be adjusted from the provided FRL by turning the valve knob.

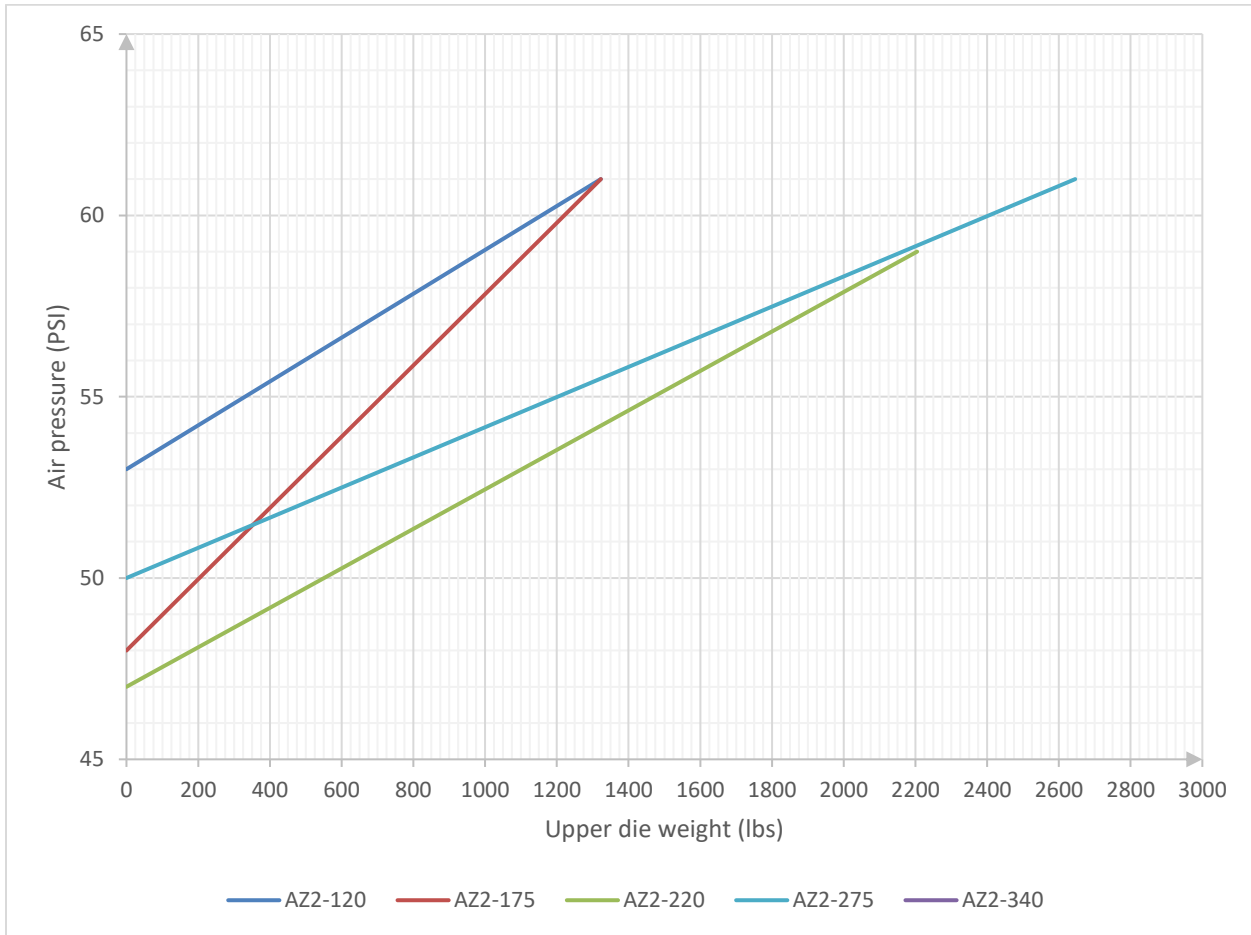

Figure 1.2.4 Counter balance air requirement

The graphs **Error! Reference source not found.** show the capacity of AZ2 presses, in kilonewtons, in function of the distance from bottom dead center, in inches. This is useful to determine the pressing capacity for a given material thickness.

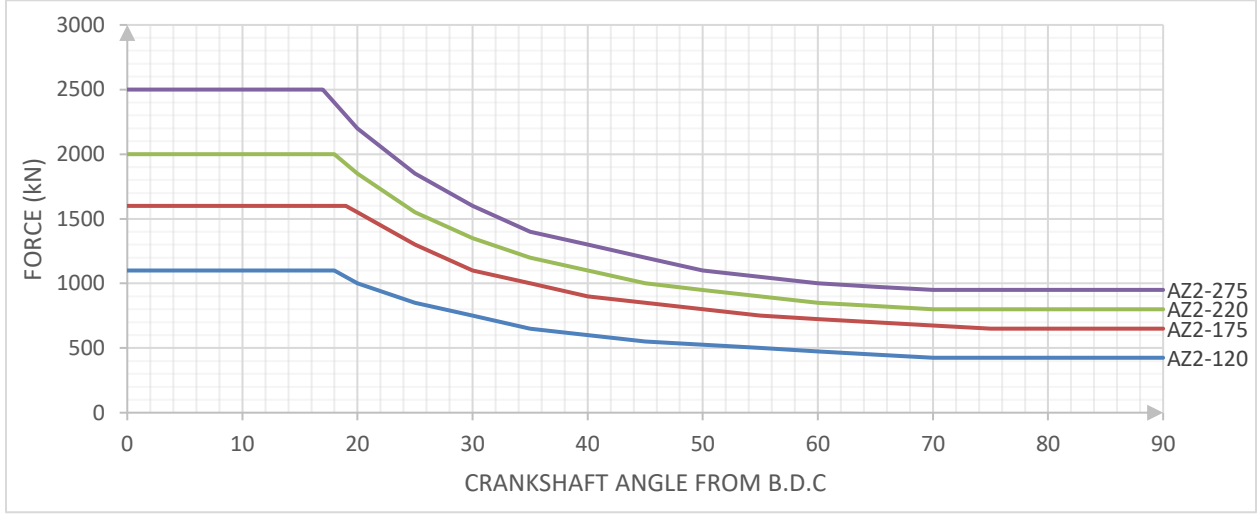

Figure 1.2.4 Capacity Curve (Models AZ2-120 to AZ2-275)



Press layout **AZ2**

Figure 1.2.5 Azimuth **AZ2** Assemblage

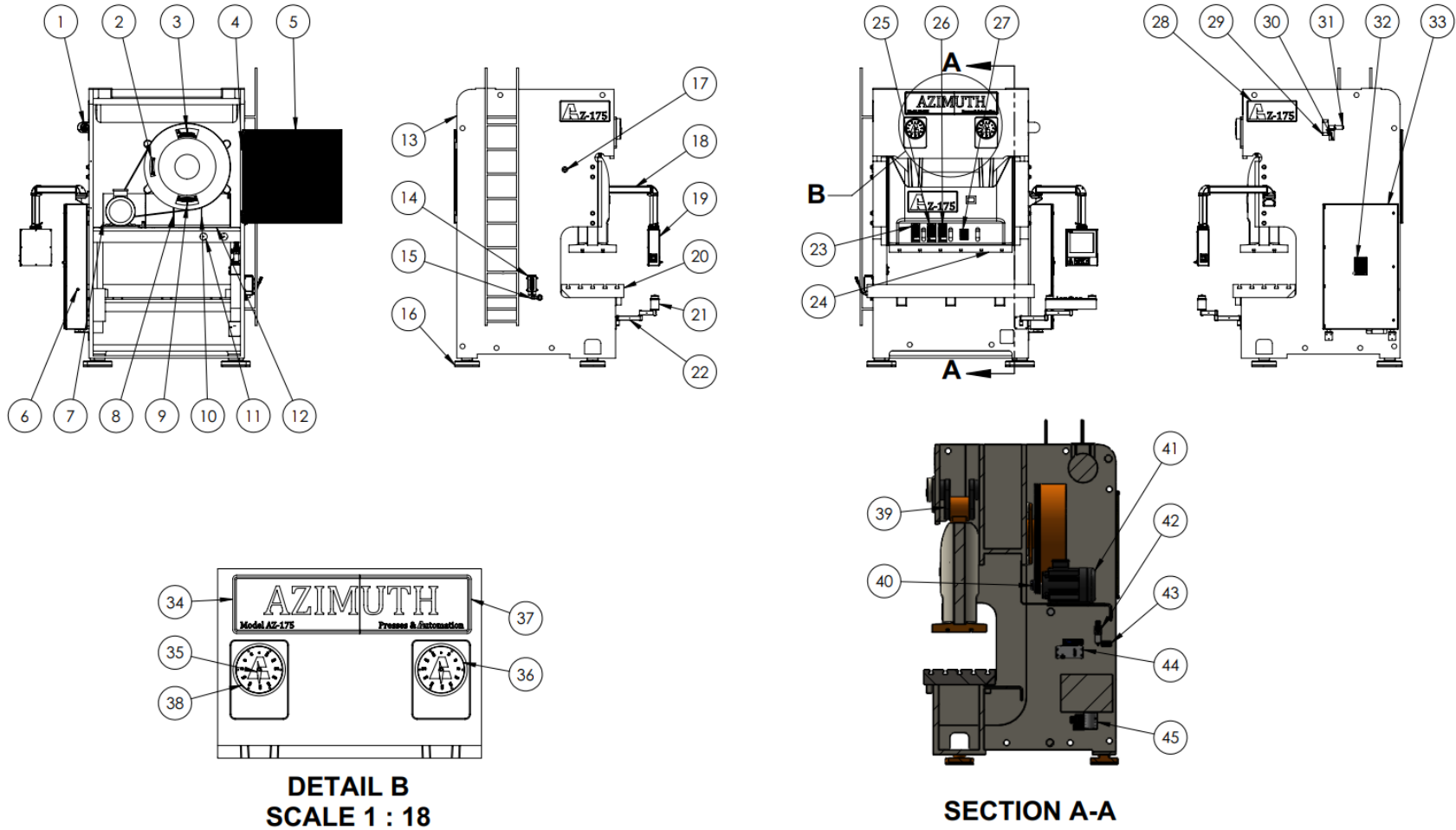



Table 1.2.5 Azimuth AZ2 BOM

ITEM NO.	PART NUMBER	DESCRIPTION
1	069.3	ENCODER SPROCKET
2	410.2	WETCLUTCH IDENTIFICATION
3	410.2	CLUTCH IDENTIFICATION PANEL
4	327.1	DOOR HIGE
5	327.1	REAR MESH GUARD
6	508	BOUTON POUSSOIR
7	0010	ANGLE GUARD
8	0010	ANGLE GUARD
9	410.2	OIL OUTLET PANEL
10	0010	ANGLE GUARD
11	005.1	PRESSURE GAGE PLATE
12	0009	PLATE GUARD
13	1001	FRAME
14	1312	OILING PUMP
15	1312	OILING PUMP ACCESSORIES
16	060.1	FOOT
17	802	GEAR OIL LEVEL
18	184AS	SWIVEL ARM-SMARTPAK HMI
19	502.1AS	SMARTPAC PRO HMI
20	1002	BOLSTER PLATE
21	550AS	DUAL PALM
22	183AS	SWIVEL ARM FOR DUAL PALMS
23	410.2	CHANGEMENT D'HUIL GEAR BOX
24	023AS	RAM SYSTEM
25	410.2	CHANGEMENT D'HUIL CLUTCH
26	410.2	CHANGEMENT D'HUILE OVERLOAD HYDRAULIQUE
27	410.2	CONVERSION TABLE
28	410.1	LOGO & MODEL
29	069.3	SPROCKET COVER
30	069	RESOLVER SUPPORT
31	069.1	WINTRISS STD RESOLVER
32	278	PANNEAU ELECTRIQUE
33	501.1AS	PRESS CONTROL
34	410.1	LOGO RIGHT
35	4001	AIGUILLE
36	410	CADRAN
37	410.1	LOGO LEFT
38	410	CADRAN
39	2001	CRANKSHAFT
40	123	PULLEY
41	069.4	MOTOR
42	1310-023	FRL
43	410.2	DRAIN WEEKLY
44	1311	OVERLOAD PROTECTOR
45	1312	GREASER



Safety precautions

Azimuth comply to safety regulation per table below :

Regulation	Description
UL 508A 3 Rd edition Issued date 2018-4-24	Industrial control panel compliance
CSA C22.2 No14-18	Industrial control panel
CSA Z142	Safety for presses

Read this operation manual carefully before mounting, operating, maintaining and checking the press to ensure operators safety and press protection.





Never operate the press until fully understanding of the principles, safety conditions and all cautions for this press.

Never operate this machine before properly understanding the related press control installed on this press.

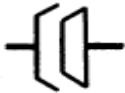

- ⚠ Before using the machine, make sure the shut height is properly adjusted to your tooling.
- ⚠ Make sure to verify proper motor voltage & secondary motor voltage prior any intervention on the machine.
- ⚠ Before using the machine with material, make sure to perform a visual inspection and try to cycle it 5 times to verify that nothing has been damaged during transport (guarding system, pitman enclosure, etc.)
- ⚠ Do not operate this machine until you've read & understood that this machine is dangerous. Placing your hands or any part of your body in this machine could result in the loss of fingers, limbs or even death.
- ⚠ Never operate this machine without the use of a guard or safety device that will always protect you from injuries.
- ⚠ Never work on this machine unless power is turned off and locked out.
- ⚠ ***Never place your hands in the machine unless the E-Stop is pressed***

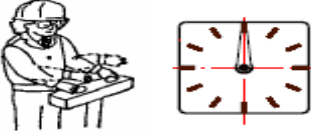



No.	Inspection	Inspection items
1		Check the clutch and brake performance in INCH mode
2		Check bolts and screws of crankshaft, flywheel, slide, connection rod, light curtain for security
3		In SINGLE mode, depress RUN button to stop slide at TDC.
4		E-STOP button is depressed, slide should stop immediately. Verify stopping time according to press control Installed.
5		Check light curtain performance, whether slide stops immediately

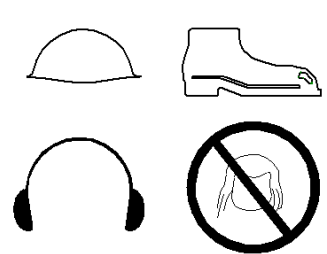
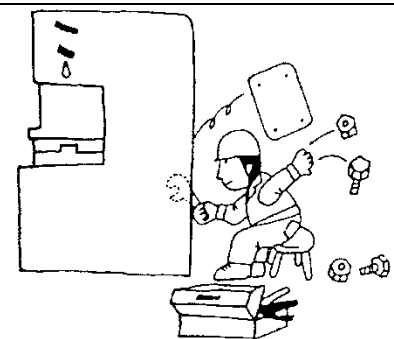
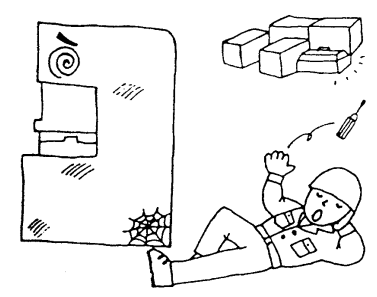
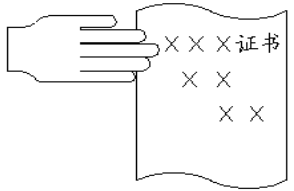

	<p>Operators must</p> <ul style="list-style-type: none"> (a). wear a safety helmet; (b). wear the safety shoes; (c). wear the earplug; (d). with short hair;
	<p>Never modify or remove the control circuit or the safety device to ensure operator's safety, otherwise AZIMUTH disclaims any liability or responsibility.</p>
<p>V cc</p> 	<p>Completely perform the periodic inspection in accordance with this operation manual</p>
	<p>Inspection, adjusting and maintenance of electrical circuits must be performed by qualified electricians with specific certificate.</p>

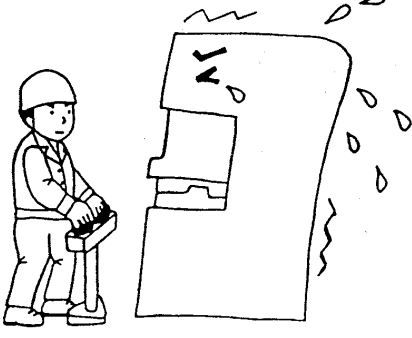

 A line drawing of a worker wearing a hard hat and safety vest, operating a large industrial press. The press is shown with wavy lines and droplets, indicating it is in use or has just finished a cycle.	<p>Ensure the press is used within the nominal capacity.</p>
 Two simple line drawings: an open book on the left and an eye on the right, representing reading and visual inspection.	<p>Read this operation procedure and confirm the switches and buttons (see D OPERATION section)</p>



3. Transport and Installation

This section represents proper anchor points & installation for rigging services.

Acceptance inspection

Check the press for any damage and the accessories in accordance with PACKING LIST, and contact AZIMUTH for confirmation with any problems.

Carrying

Consider the crane capacity and wire cable capacity for the big and heavy press, especially pay attention to the extended part.

Lifting cautions: check wire cable surface, never lifting in 90°; cover the machine corners with cloth for protection during lifting; never use chains for lifting; the machine only allowed to be pulled but not pushed; keep safety distance during lifting.

Lifting procedures:

- (1). Cross the proper wire cables as per machine weight and set the wire cable on the sling bolts and hooks.
- (2). Set the hook on the proper position, and lift and adjust the machine slowly and properly to keep the machine balance.
- (3). Lift the press carefully and slowly to ensure safety.

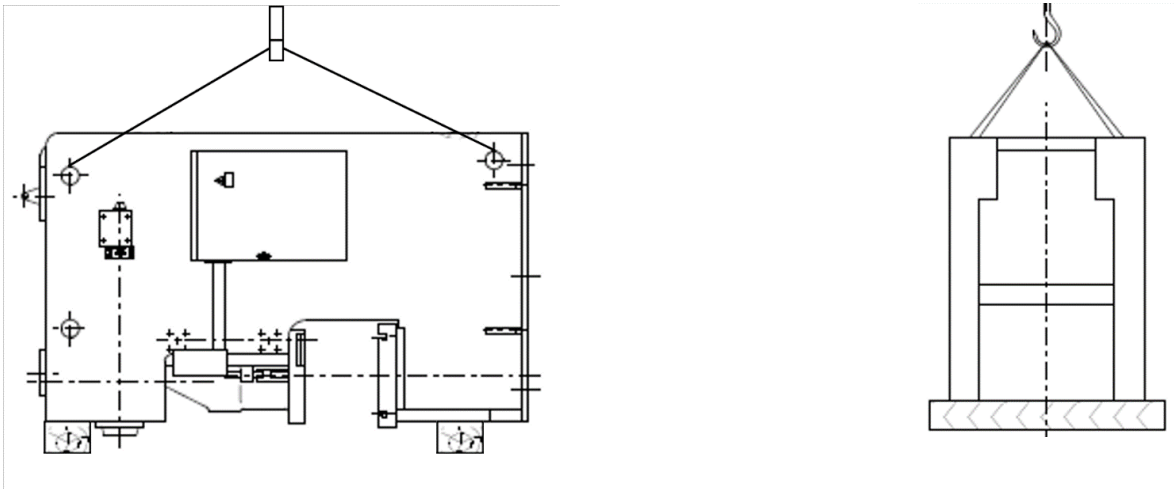
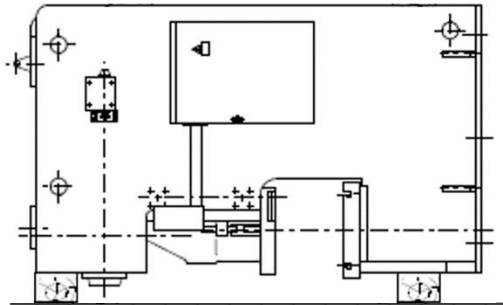

Figure 3.2.3 Lifting procedures



- (1) For the air lines at the two sides, so lay down the press as shown below: lay it down at the front side and inserted with wood blocks to protect the external press.

Figure 3.2.4 lay machine down at the front side



Note: The length of underlay wood blocks must longer than the width of press.

- (2) If the machine is higher than workshop door or crank is not available, upside down the machine and move it with round rolling bars for short distance movement, and pay much attention to the safety.

Figure 3.2.4 Move machine with round rolling

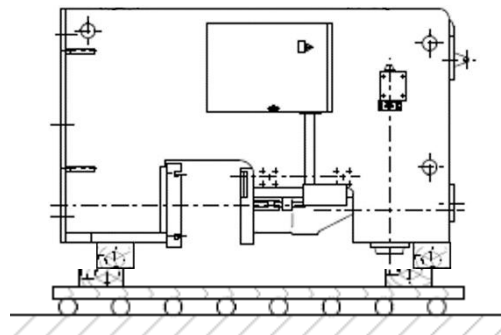



Note: The wood blocks must be able to support the press weight.



Put the press in a dry place for 3-5 days to dry the motor and electrical components. And check insulation with instrument if necessary.

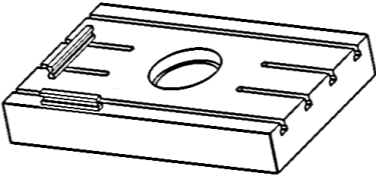

Installation of frame and bolster

	<p>The press has been coated rust proof oil before transportation, consequently clean it before installation.</p>
	<p>Foundation installation: Lay the press onto the foundation and level the press bolster (see 4.2). After leveling, fix the anchor screws, fill in concrete (cement to sand: 1:3) into the square holes, only operate the press when concrete is completely dried.</p>
	<p>Buffer installation: First install the buffer underneath the press, and lay press on ground to check the bolster levelness with level gauge. Adjusting as shown.</p>





	<p>First completely clean the bolster and check whether it locked tight or not. Cross lay the level gauge in the middle of bolster in the portrait direction of press (as shown), the reading must not beyond 0.2/1000mm.</p>
	<p>If there are differences, insert pads under frame feet to level front to back and left to right. If it with buffer, just adjust the screw of buffer to level it.</p>

Note: Pads should at least as big as press feet to support the weight. Check the level after first month use and check it every half year.

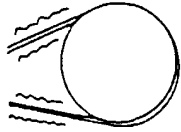

Try to install main motor on the frame during transportation. IF is it must be disassembled, the re-installation procedures are as following:

	<p>Clean motor, motor wheel, motor mounted plate, flywheel groove. Clean the V belt with cloth, not solution.</p>
	<p>Check main motor</p>
	<p>Move the motor to the installation position, do not lock tight firstly, and support the motor weight with hanger. Measure the center line of motor wheel and flywheel groove and move the motor to be centered and fasten motor with bolt at last. If motor wheel and flywheel are not centered properly, it will accelerate wear of V belt groove and motor bearing. (as shown)</p>

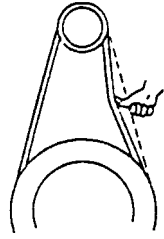

Note: Do not mount V belt onto motor wheel tightly. The proper tension is to depress the V belt down 16mm/m. If not, loose and turn the four lock bolts to raise motor base and finally fasten the lock bolts after adjusting.



Parts	Kind of lubricant			Oil quantity required	
Oil reservoir for drive gear	#320 gear oil (SINOPEC)	Gear 632 (MOBIL)	OMALA 320 (SHELL)	25t	10L
				45t	17L
				63t/80t	24L
				110t	27L
				125t	28L
				160t	65L
				200t	70L
				250/315t	205L
				400t	230L
Oil reservoir for slide ball base	#46 anti wear hydraulic oil (SINOPEC)	DTE25 (MOBIL)	TELLUS 46 (SHELL)	0.8L	
Thread of connection rod				0.2L	
Oil reservoir for hydraulic overload protector (Rigid overload protector: no oil reservoir)	#32 anti wear hydraulic oil (SINOPEC)	DTE24 (MOBIL)	TELLUS 32 (SHELL)	16t-125t	2.5L
				160t-315t	5L
				400t	8L
Wet clutch	ATF (automatic transmission fluid) (SINOPEC)	ATF220 (MOBIL)	DEXON III (SHELL)	6L	
Motorized grease pump	#0 extreme compressed lithium base grease (SINOPEC)	MOBILUX EPO (MOBIL)	ALVANIA EPO (SHELL)	2L	
Manual grease pump				0.6L	



(with cushion)				
Motorized oil pump (Option)	#68 machine oil			16t-80t: 4L 110t-160t: 6.3L 200t-400t: 8L



Clean the internal pipe lines with air hose first and then connect the air inlet to the air line joint of the rear side press. (Joint with Rc1/2 thread and connected as shown.) Required air pressure is 0.55MPa.
Air inlet: Rc1/2 joint.



Installation & START-UP Functional diagram

1. Air- Filter
2. Regulator (80-85 PSI)
3. Air lubricator
4. Air tank (if necessary)
5. Electrical dual valve
6. Rotary union
7. Air clutch & brake – Flywheel of the press

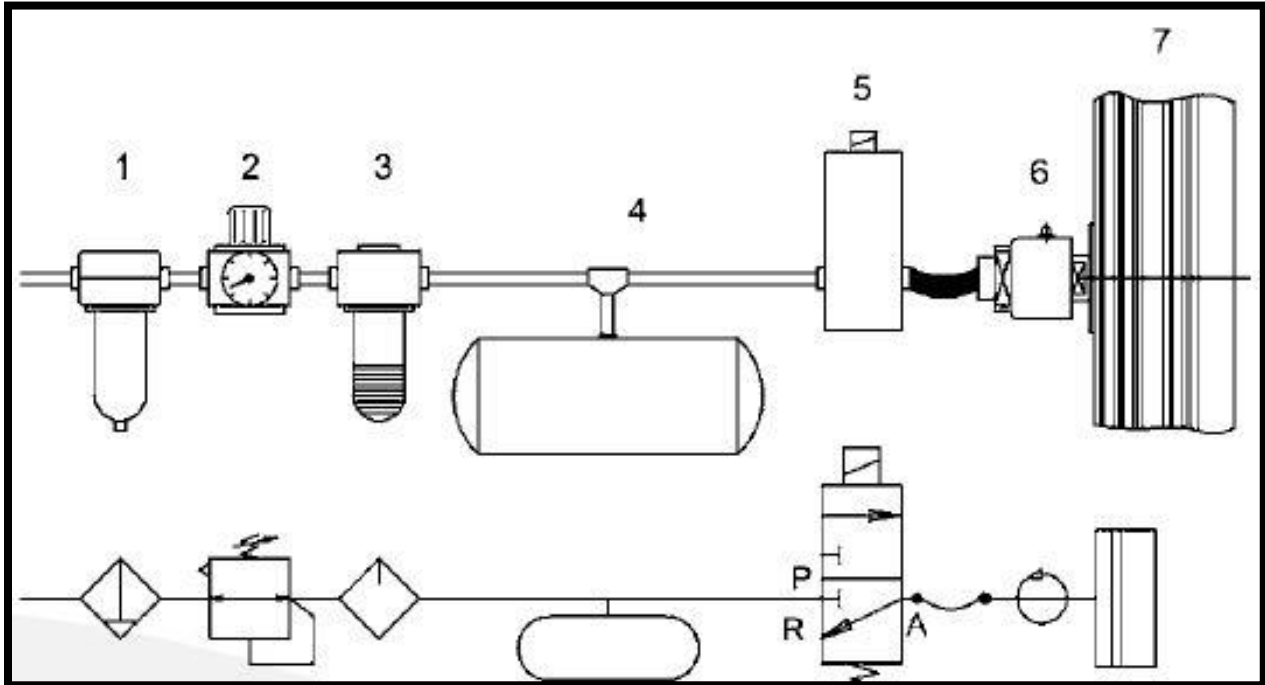

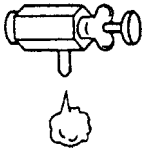



Figure 3.5.3 Air flow



	1. Check lubrication oil quantity of gear box
	2. Check lubrication oil quantity of slide ball base
	3. Check oil quantity of every oil tank for lubrication pump
	4. Check oil quantity of oil tank for hydraulic overload pump



	<p>1. Check air pressure of air inlet, clutch and balance cylinder</p>
	<p>2. Check no air leakage of every piping</p>
	<p>3. Check no dirt of water separating air filter</p>



1. Depress E STOP button to check itself locked or not and check slide stops immediately or not

Main components and Function (AZ1 & AZ2)

Main components - AZ1

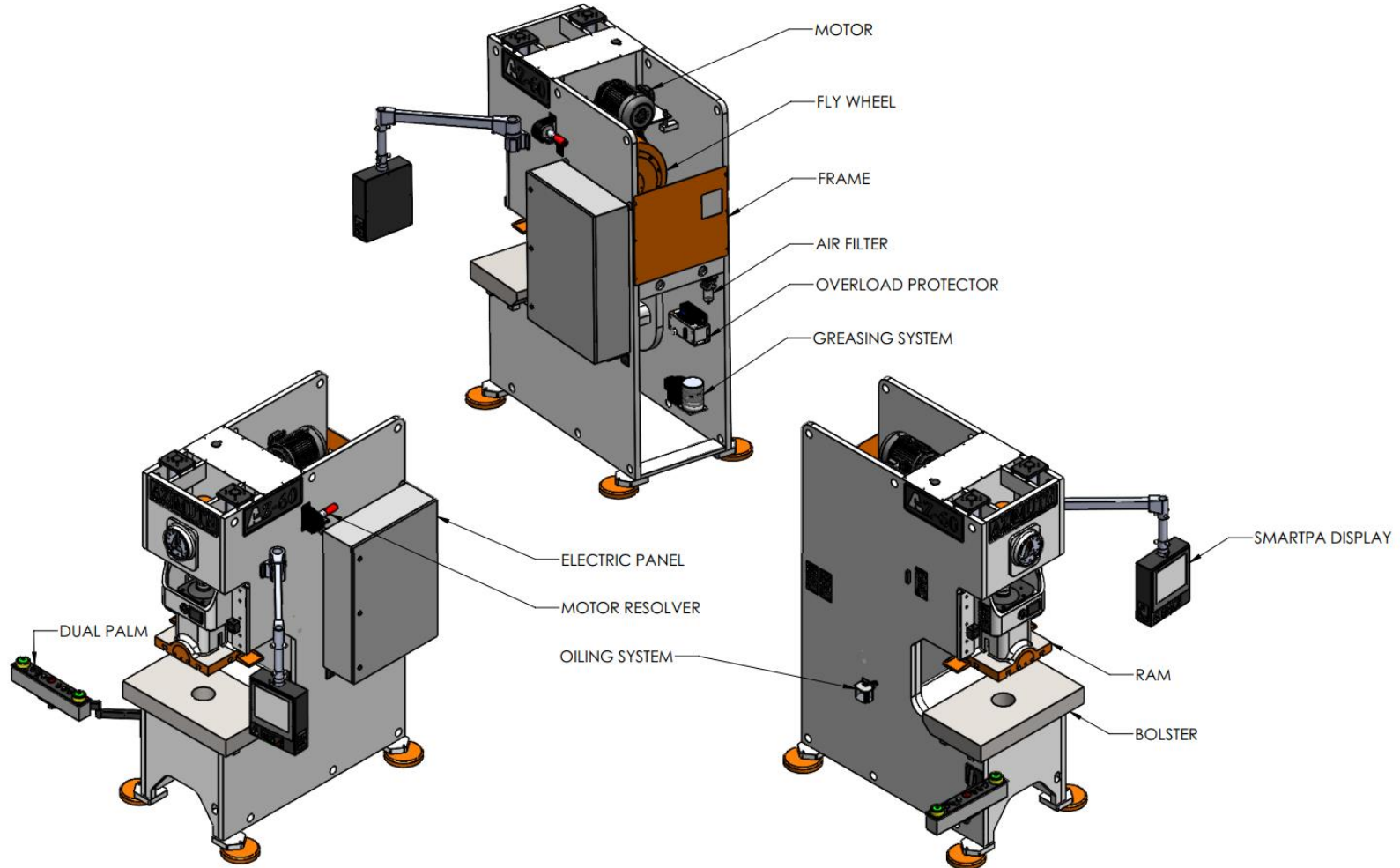



Main components - AZ2

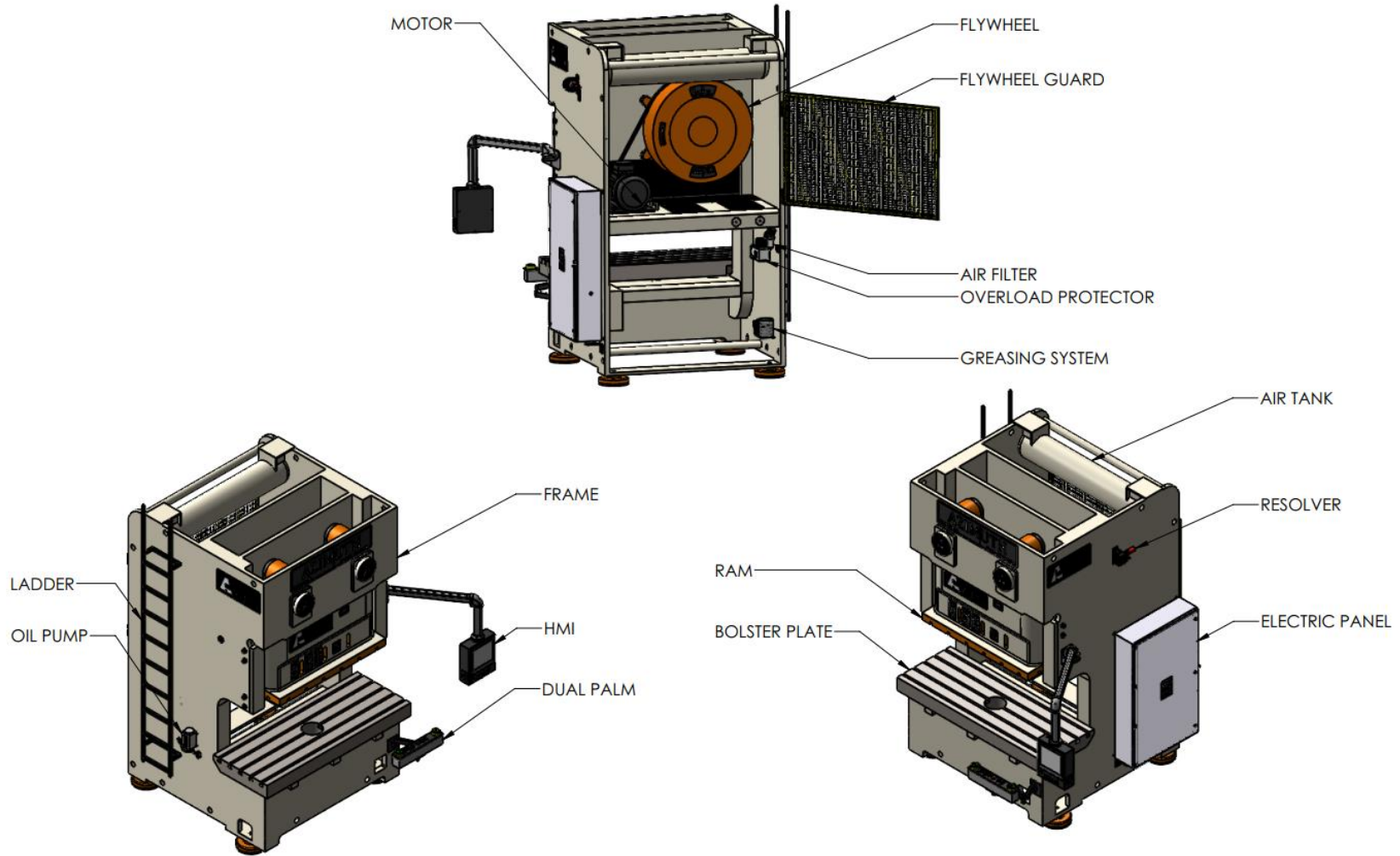





This sections covers the maintenance procedure for this press. See section

Mechanical Set-up

This section covers the mechanical set-up of the AZ1 press. Please make sure to fully understand these instructions before attempting to make mechanical adjustments to the machine.

Adjusting the Shut Height

The shut height can be adjusted using the operator station on AZ1-2 presses.

To adjust it, the “RAM ADJUSTMENT” key must be turned to either up or down. Pressing the START button will move the ram up or down depending on the position of the key switch.

The shut height cannot be adjusted while operating the press.

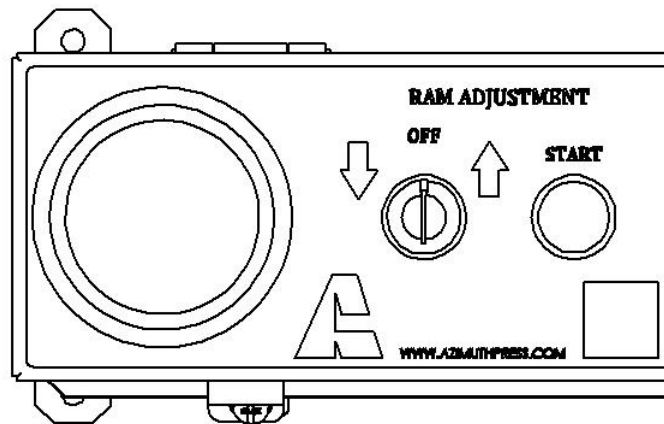



For the press to function correctly and to ensure longevity, the ram and gibs must be periodically inspected, cleaned and adjusted.

Cleaning the Ram Contact Surfaces

To avoid premature wear of the contact surfaces, always make sure there is no dust or debris stuck on the sliding surfaces.

Check for excessive dust or abrasive particles such as metal chips. These particles will scratch and damage the ram and gibs with time.

It is recommended to always wipe down the sliding surfaces before running the machine. Always use towels to clean the press.

Remove excessive grease & verify no dust or particles are present in the grease.

Do not use a compressed air jet to clean the ram and gibs; it will force debris between the ram and the gibs.



Periodically check the clearance between the gibs and the ram to make sure it stays within specification. The clearance can be checked using feeler gauges. Refer to the table **Error! Reference source not found.** to check what is the specification for each press model.

Table 6.1.2.2 Specified Gibs Clearance **AZ1**

Press Model	Specified Clearance Between Gibs & Ram (inches)
AZ-60	0.003
AZ-80	0.003
AZ-100	0.005
AZ-125	0.005
AZ-175	0.005
AZ-200	0.005
AZ-250	0.005
AZ-315	0.0075

Table 6.1.2.2 Specified Gibs Clearance **AZ2**

Press Model	Specified Clearance Between Gibs & Ram (inches)
AZ2-120	.005
AZ2-175	.006
AZ2-220	.006
AZ2-275	.006
AZ2-340	.008



If the clearance between the gibs and the ram is out of specification, it means the wear plates have worn out and must either be shimmed or replaced.

To adjust the gibs clearance, the gibs must first be removed. This gives access to the wear plates. These plates can then be shimmed by the correct amount to get the clearance back in specification.

The gibs can then be put back on and the bolts, tightened.

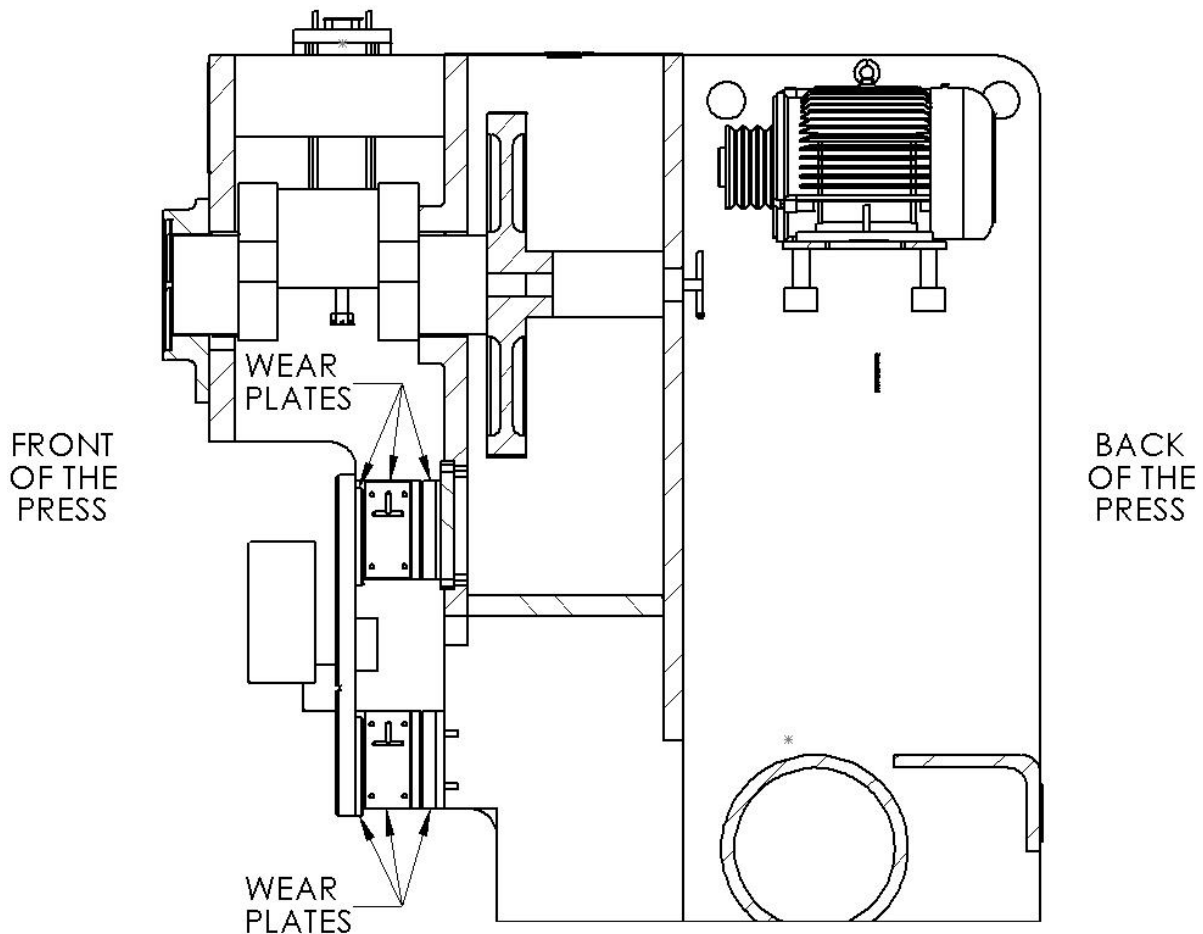



Parallelism between the ram and the bed of the press is critical for the press to function properly. To verify it is within specification, a dial gauge and a magnetic base are required.

To check the parallelism, mount the dial gauge on the bed of the press. Put the dial gauge pin against the ram and slide the magnetic base on the bed, going from one end of the press to the other, as shown in **Error! Reference source not found.**

The variation between the lowest point and highest point must not exceed the specification of 0.001in/ft.

If the parallelism is out of specification, contact Azimuth Machinery.

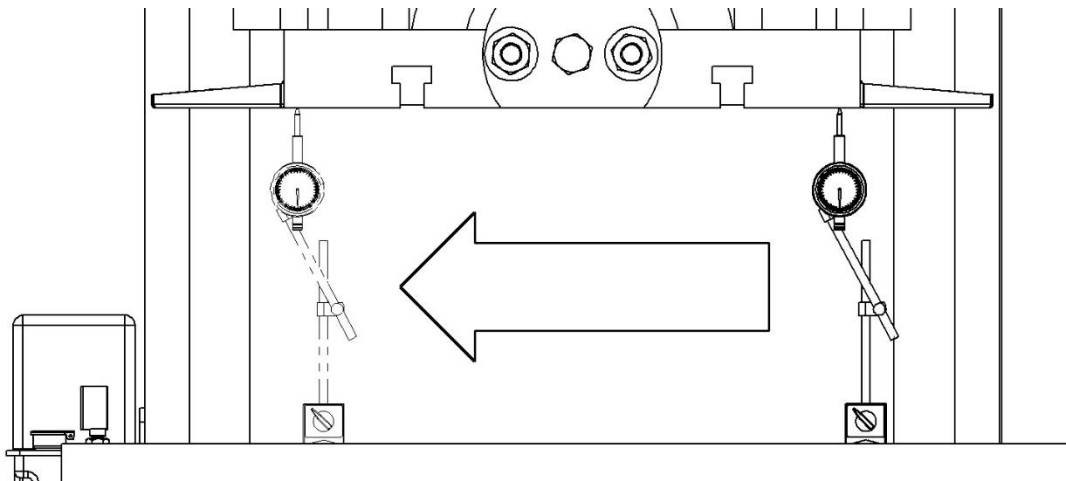



Main bushing clearance & ball-screw clearance is an important point to verify every year of operation.

Using a bottle jack of approximately 20T, place it under the bed.

Measure total clearance & take notes.

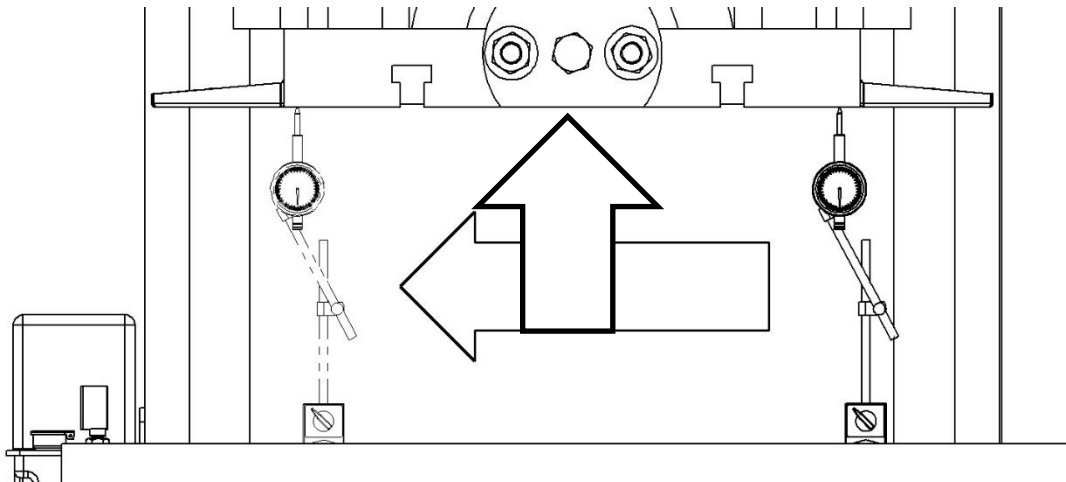



It is important to make sure the drive belts are properly tensioned. The belt tension can be adjusted with the four bolts that hold the motor plate behind the press. Make sure to turn the four bolts evenly.

Failure to do so may misalign the motor pulley and flywheel, causing the belt to wear prematurely.

The correct tension is achieved when the belt can only be depressed 0.2 in/ft (16 mm/m)

The purpose of the four smaller bolts is to lock the bigger bolts. Therefore, make sure to loosen them before adjusting tension and to tighten them when done.

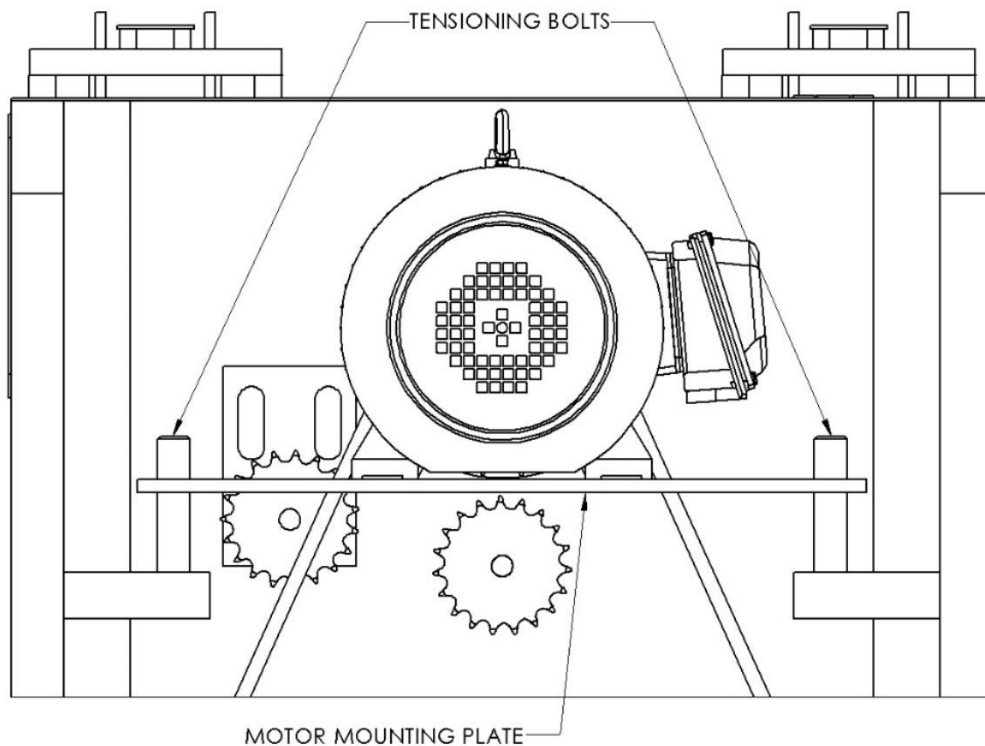

Figure 6.1.3 Belt Tensioning



This press is equipped with an hydraulic overload protection device. The hydraulic overload device is adjusted to approximately 125% of the total press capacity.

This device prevents any overload of the press from bad set-up of the operator, parts stacking, overtonnage, etc.

This hydraulic overload pump operates with Air-applied to it. When air is properly applied, the system will automatically bleed by itself to pressure the hydraulic units inside the RAM.

In order to verify the proper functioning, verify these points :

1. Verify Oil inlet is properly closed.
2. Oil level shouldn't be at more than half when pump is pressurised
3. Open Screw plug for air bleed. The pump should start functioning & should give an alarm to the press control.
4. Close the vent & the pump should pressurise & stop functioning.

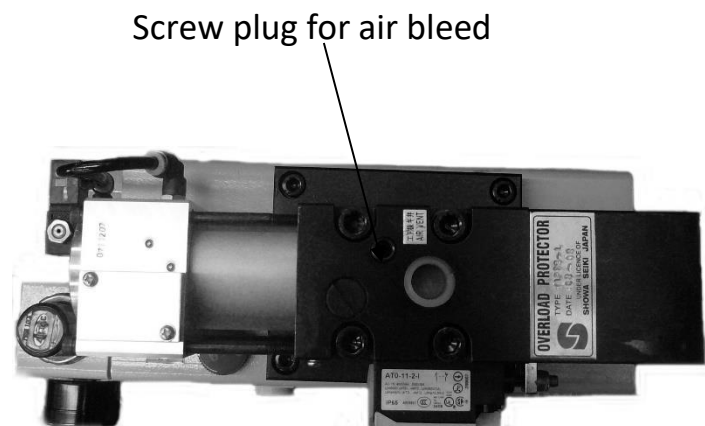
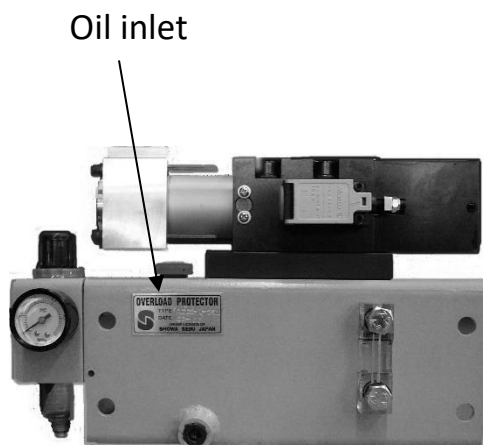



In a rare case of bad hydraulic overload adjustment, you can readjust maximum pressure at which the hydraulic overload will trigger an alarm by tightening the screw highlighted in red below.

Only a certify technician or maintenance operator should adjust the hydraulic overload.

1. Do not attempt adjusting hydraulic overload without a certified technician. This can result in severe damage to the machine.
2. Rotating the screw clockwise will increase value of the actual overload of the machine.
3. Rotating the screw counter clockwise will reduce value of the actual overload of the machine.

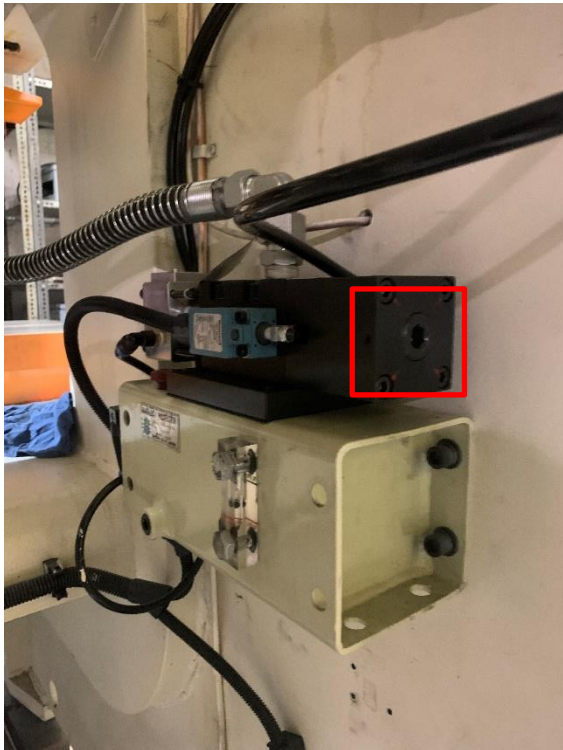



The press adopts combined wet multi-discs pneumatic friction clutch brake which are mechanical interlocked. 6 friction pads of clutch and 6 friction pads of brake are enclosed with oil groove of flywheel.

An oil film among friction pads and dual discs transmits the torque with small wear of friction pads and lower engaged noise. When dual solenoid valve is powered on, compressed air inlets and then pushes the clutch friction pads move right to transmit flywheel energy to gear shaft.

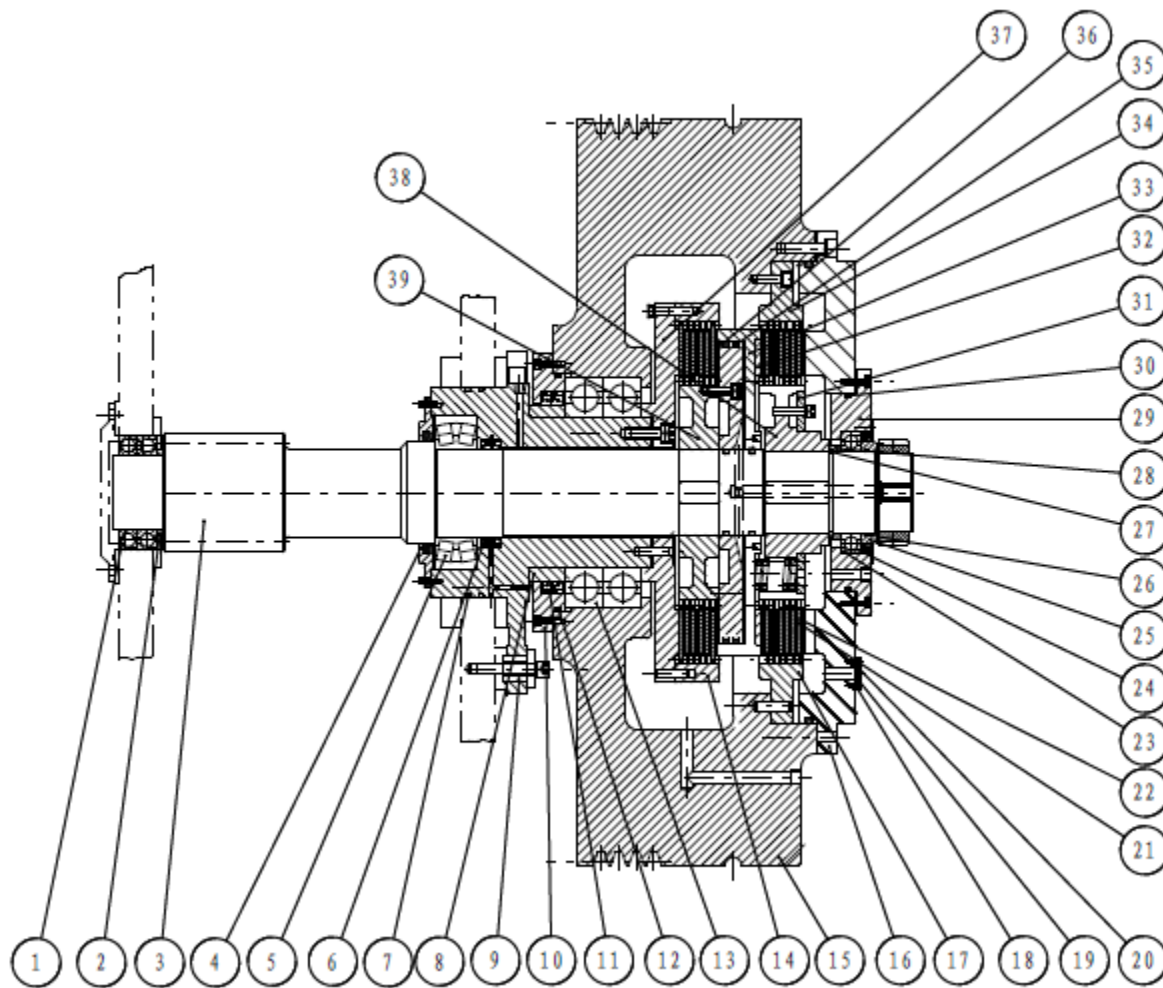



When dual solenoid valve is powered off, compressed air gets out and cylinder move left under spring force to fasten brake friction pads to stop gear shaft and slide immediately. Construction is as following:

Figure 7.4.3 Clutch Assemblage

Table 7.4.3 Clutch BOM

Item	Description	Item	Description	Item	Description
1	Bearing	2	Sleeve	3	Gear shaft
4	Left cover of quill	5	Bearing	6	Skeleton seal
7	O ring	8	Sleeve	9	Guide sleeve of quill
10	Left cover of flywheel	11	Skeleton seal	12	O ring
13	Bearing	14	Plate	15	Flywheel
16	End cap	17	Flywheel internal gear ring	18	Oil leveler cover
19	Oil sight plate	20	O ring	21	Friction pads
22	Spacer	23	Bearing	24	Skeleton seal
25	Bearing cover	26	O ring	27	Retainer
28	Sleeve	29	Bearing base	30	O ring
31	Spring plate	32	Cylinder internal gear ring	33	Cylinder body
34	Flywheel internal gear ring	35	Star ring	36	Piston
37	Brake disc	38	Brake gear	39	Clutch gear



Two counterbalance cylinders are hung on the top frame. The piston rod connects with left and right walls of slide to balance slide and upper die weight for slide performance accuracy.

Verify section Counter balance Settings for more details.

Cylinder body with thin wall is an upside mounting construction. Once press geometric accuracy is adjusted and slide is deviated, to compensate by clearance of block which connected with slide with balance cylinder piston rod.

Construction is as following:

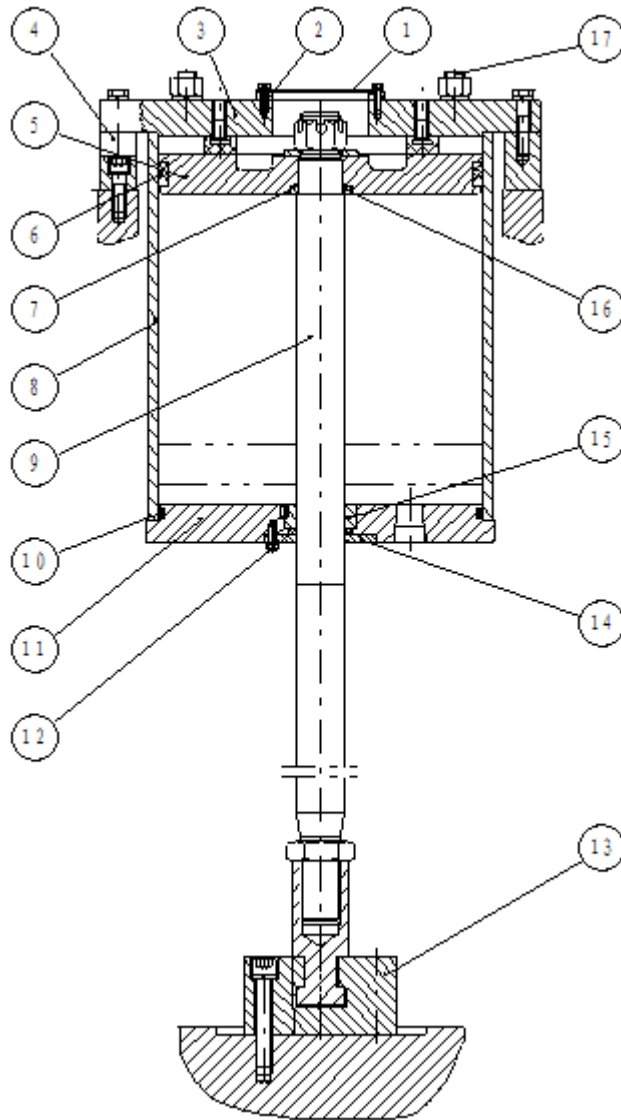



Item	Description	Item	Description	Item	Description
1	Cover plate	2	Washer	3	Cylinder cover
4	Block	5	Piston	6	Y ring
7	O ring	8	Cylinder body	9	Piston rod
10	O ring	11	Cylinder bottom	12	Y ring
13	Hanger	14	Cover	15	Internal bush
16	Seal washer	17	Tie rod		

Seals of counter balance:

Item	Description	Press model	Specification	Qty.
6	Y seal ring	AZ2-80	Y seal ring\230x250x12	1
		AZ2-110	Y seal ring240x280	1
		AZ2-160	Yx seal ring D320\JB/ZQ4264-1997	1
		AZ2-200	Yx seal ring D400\JB/ZQ4264-1997	1
		AZ2-250	Yx seal ring D450\JB/ZQ4264-1997	1
7	O ring	AZ2-80	O ring 36.5x3.55\DICHTOMATIK	1
		AZ2-110	O ring45x3.5\ EK	1
		AZ2-160	O ring50x3.55\ EK	1
		AZ2-200	O ring55x4\ EK	1
		AZ2-250	O ring58x4\DICHTOMATIK	1
10	O ring	AZ2-80	O ring236x7\GB1235-76	1
		AZ2-110	O ring270x5\DICHTOMATIK	1
		AZ2-160	O ring310x5\ EK	1
		AZ2-200	O ring386x6\ EK	1



		AZ2-250	O ring440x4\DICHTOMATIK	1
12	Y seal ring	AZ2-80	Y seal ring\45x56x7	1
		AZ2-110	Y seal ring\50x60x6	1
		AZ2-160	Y seal ring\55x65x6	1
		AZ2-200	Y seal ring\60x71x7	1
		AZ2-250	Y seal ring\65x75x6	1



Here's the procedure on how to change oil for each oiling point on the AZ model.

It is important to follow the change frequency in order to have a good oil quality.

The table 1 shows the type of oil to use on the press.

<i>Location</i>	<i>Type of oil</i>	<i>Change frequency</i>
1. Main gearbox	Hydraulic oil 68	Every year
2. Counter balance oil	Hydraulic oil 68	Fill oil reservoir when Empty
3. Hydraulic Overload	Hydraulic oil 32 (clear)	Every 6 months
4. Screw adjustment & ball-screw	Hydraulic oil 68	Monthly
5. Wet-Clutch	Hydraulic oil 32 (red)	Every year

1. Main Gear-box

The main gearbox is immersed in the oil bath. **Change the oil every year** of operation. Here's the procedure on how to change the oil bath of the main gear-box.

1. Drain the oil by accessing the drain valve at the bottom of the tank. Drain until there is no more oil inside the tank.





2. Remove the top plate to access the main gear-box & verify the gear state. Using air, clean inside the gear box by making sure no dirt is inserted inside the gear box.



FIGURE 7.4.9.1 MAIN GEARBOX



3. Using the side level, fill oil until it is half-full or at 1/3 of the pinion gear.





2. Counter balance-Oil

The counterbalance oiling pump is used to oil the main seal inside the counter balance air-cylinder.

Using the proper oil, fill-in the oil accordingly every.

3. Hydraulic overload

The hydraulic overload pump is a very important components that prevent mechanical failure on the machine when overloading it.

1. Loose open the drain screw to drain the oil tank. Drain all the oil inside the tank.

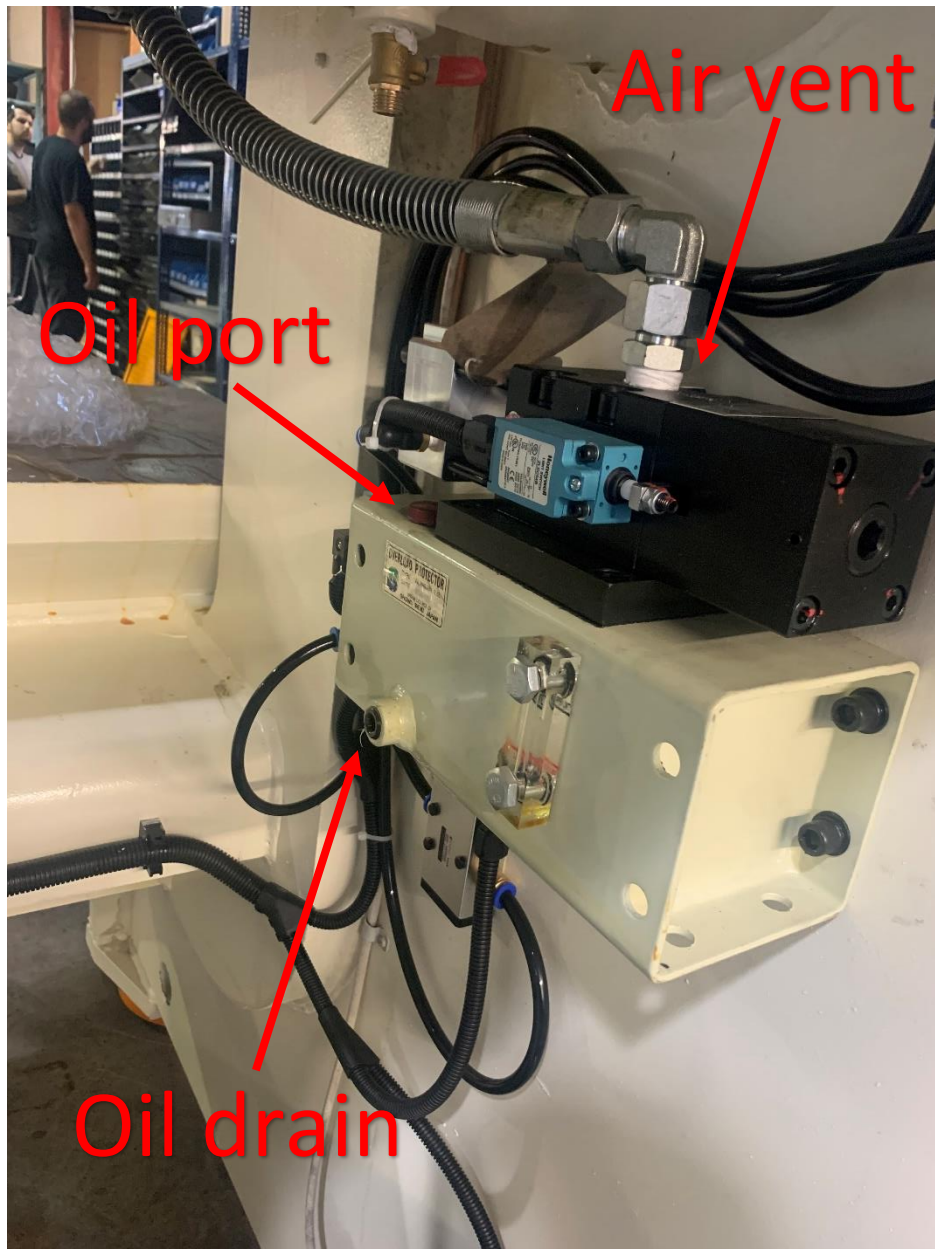



2. Open the air vent. The pump will start & drain the remaining oil inside the tank & hose to the RAM.

3. Tighten the oil drain screw back & remove the oil port plug.

4. With the air-vent open fill-in the oil until it is $\frac{3}{4}$ full.

5. Tighten the air-vent back. The pump will by itself stop pumping.

6. Make a clearance check before operation.

4. Screw adjustment & ball-screw

The motorized screw adjustment is driven by a worm gear within the RAM assembly.

1. Remove the oil port screw.
2. Remove the oil drain screw & drain the oil bath.
3. Replace with proper oil.



FIGURE 7.4.9.4 ADJUSTMENT SCREW OIL PORT INLET

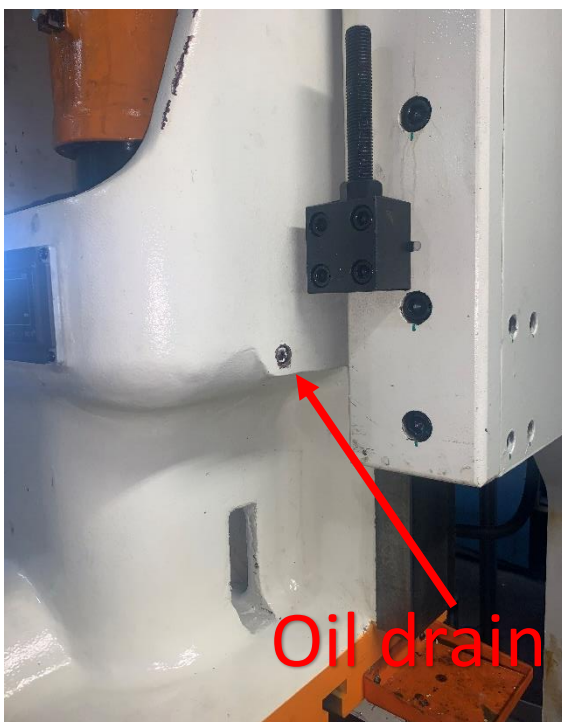

FIGURE 7.4.9.4 ADJUSTMENT SCREW OIL PORT OUTLET



5. Wet-clutch

The wet-clutch is located at the back of the machine. It is important to change the oil every year in order to have a proper torque to the clutch &

1. Place the flywheel in a horizontal position so the oil level is on the right
2. Remove the drain screw to drain the oil bath within the wet-clutch
3. Tighten the drain screw back & rotate the flywheel approximately 30 degrees to access the oil port.
4. Fill-in the clutch oil until the oil level is a the middle when the oil level is on the right side.

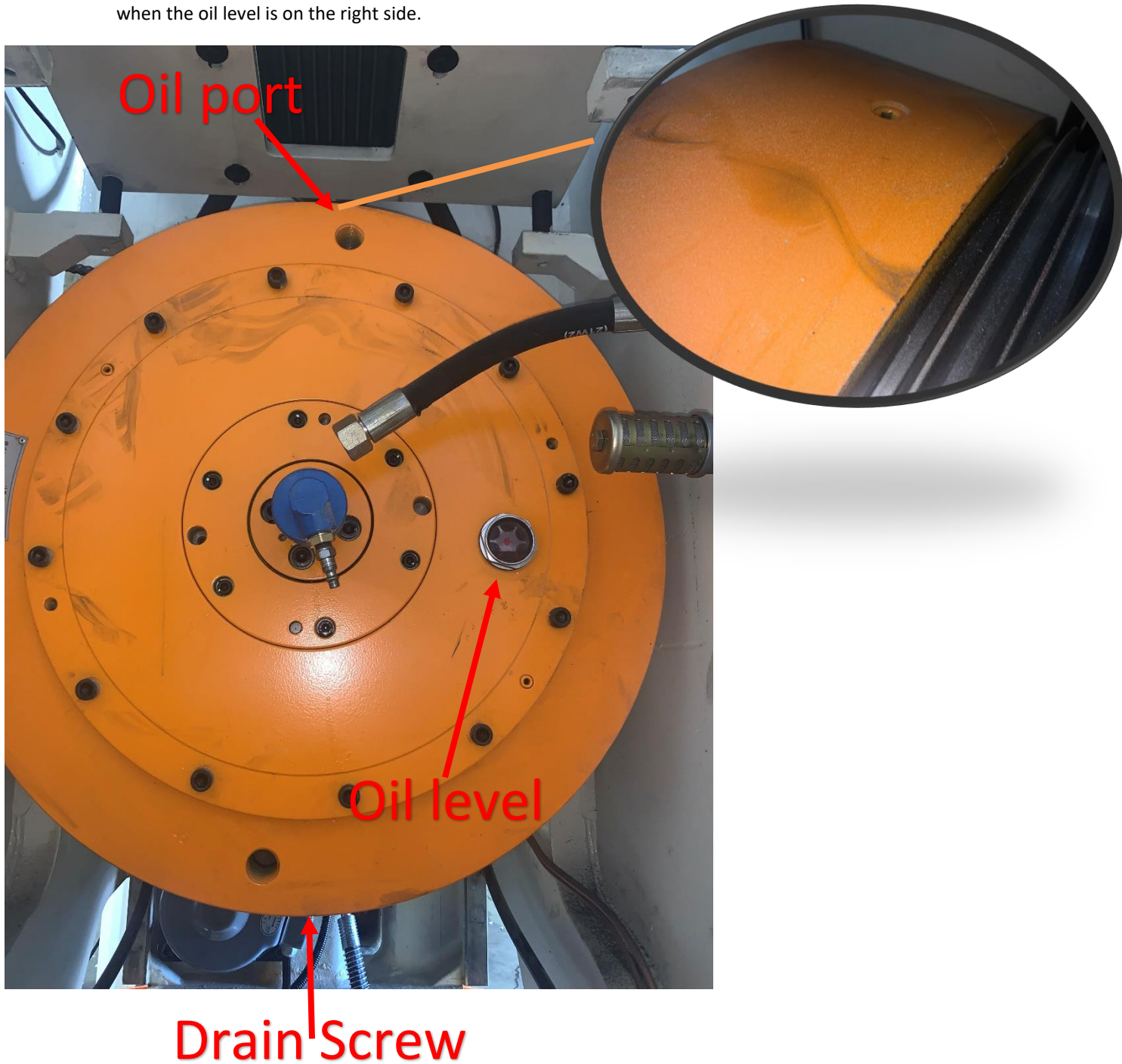

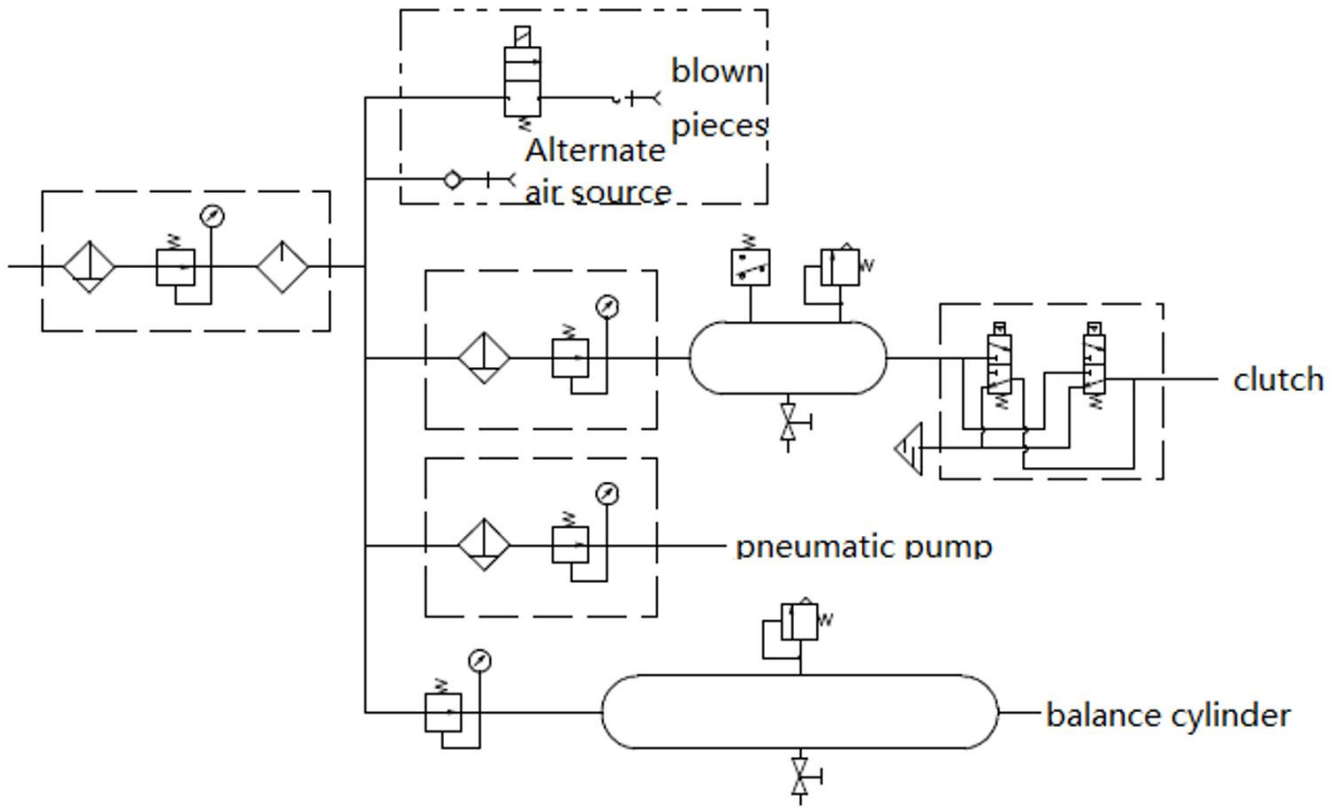



Operating the Press

This section explains how to operate the press. Please make sure to understand these instructions before operating the press.

Using the Operator Station

The station allows the operator to control the press.

- The DUAL PALMS start the motion of the press and must be pressed simultaneously.
- The RAM ADJUSTMENT switch puts the press in shut height adjustment mode.
- The START button activates the ram adjustment motor. See section **Error! Reference source not found.** for the shut height adjustment procedure.
- The LIGHT button turns on the light of the press.
- The EMERGENCY STOP button stops the press in case of an emergency, and should only be used accordingly.
- The TOP STOP button stops the press when the ram is at top dead center.
- The PRIOR ACT button allows the press to be started in continuous automatic mode.
- The MICRO-INCH switch is optional. It allows micro-movements which are programmable in the controller.

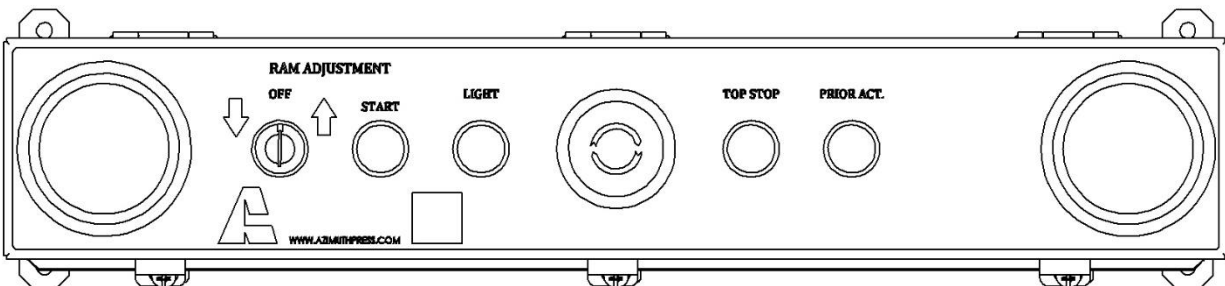

Figure 6.2.1 Operator Station



This section explains how to use the different auxiliary and optional equipment on the press.

Automatic Oiling System

Azimuth presses are equipped with an automatic centralized lubrication system for main bearing, bushing & gibs. The table below gives the important information relative to the oiling system.

Table 6.2.3.1 Automatic Oiling System Specifications and Default Settings

Idling time	800 minutes
Running time	5 seconds at start-up and after idling time
Oil type	Shell Tellus S2 M68 or equivalent

To change the oiling parameters:

- Press & hold the Set key;
 - Running time will appear, in **seconds**;
 - Change with the arrow if needed;
- Press & hold the Set key;
 - Idle time will appear, in **minutes**;
 - Change with the arrow, if needed.

To run the oiling system manually, press the Set key once.

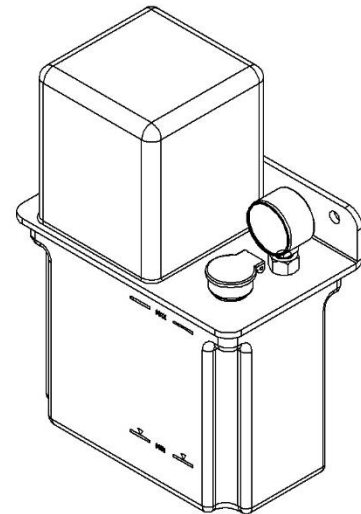

Figure

6.2.3.1 Automatic Oiling System

6.2.3.2 Automatic Greasing System



Azimuth presses are equipped with an automatic greasing system. This system triggers with the press's controller.

Grease levels must be routinely checked by the operator, and it must be refilled and bled when the grease level is too low. The press control will notify the operator with an error when it is the case.



To fill the Automatic Greasing System, remove the fill plug, then pump grease into the system until the reservoir is full. Put the fill plug back on.

Note that there is air in the reservoir after this procedure, which will interfere with the operation of the grease pump.

Unlike the Automatic Oiling System, the Automatic Greasing System will not function properly if air is present in the pump. It is therefore important to follow the bleeding procedure Error! Reference source not found..

Bleeding the Automatic Greasing System

To bleed the Automatic Greasing System once it is freshly refilled, first start it using the press controller. With a wrench, loosen the bleed screw until grease comes out. Wait until air has completely escaped the system, then tighten the bleed screw.



The greasing cycle works based on 3 main parameters:

Number of cycles : This is the amount of cycle counted by the grease sensor on the top of the press & greasing manifold.

Max allowable seconds per cycle : This is the maximum amount of time allowed to the grease cycle. IN other words, the grease sensor must turn on or OFF within 9 seconds.

Hours before cycling : Idling time before operating.

TABLE 6.2.3.2.1 GREASING CYCLE PARAMETERS

Number of cycles	Programmable from press control interface
Max allowable seconds per cycle	15 secondes
Hours before cycling	40h – Programmable from press control interface
Fault related to greasing cycle	2 flashes from fault indicator

Please refer to the below video to understand how the block divider valve.

[\(32\) Intecs SKF Lincoln Quicklub Progressive Lubrication System - YouTube](#)





Azimuth presses which are equipped with light curtains have a three-position key switch on the electrical panel which allow blanking or no blanking options.

Blanking allows for a small object to be introduced inside the light curtain without triggering the light curtain to stop the press.

Never position the key switch in the middle position – it will cause the light curtains to cease functioning properly and with it the press as well.

Make sure to power on and off the press again for changes to take place when switching between blanking and non-blanking.

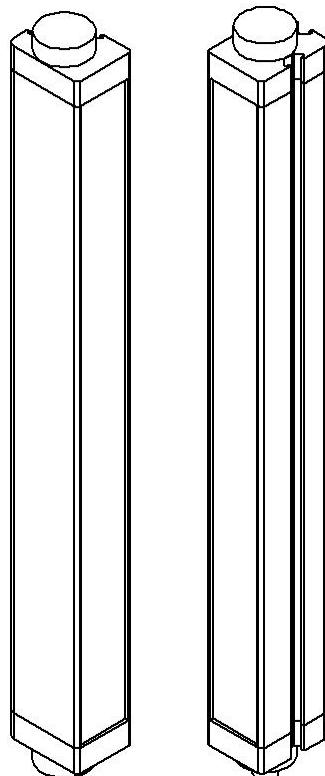

FIGURE 0.1 LIGHT CURTAINS



This section covers the troubleshooting section for mechanical issues. Please always refer to press control for any troubleshooting regarding controls of the press.

The overload from motor adjustment is an electric protection from overheating the main motor for the adjustment of the press. Here’s a few reasons why the adjustment’s motor could overload while trying to set up your tooling

TABLE 8.3 RESPONDING TO AN OVERLOAD FROM MOTOR ADJUSTMENT

Possible problems	Solution
Bad air-counter balance	Verify the air going to the counter balance. Make sure the counter balances air-pressure is properly set. Make sure there is no leak from the balance.
Improper parallelism between the RAM’S assembly & the upper shoe. Problem with main bushings from die-set	Loosen up the lower bolts from your tooling (lower shoe) making sure there is restriction on the die-set’s bushings & the sliding part of the RAM. Try to adjust again. If the RAM is moving, something’s wrong with the tooling. Verify your tooling.
	Remove tooling from your press. Try adjusting the RAM without any tooling in it. If the RAM’S moves properly, verify your tooling. If not, go to next possible problems.
Bad adjustment motor	Unmount the adjustment motor from the back of the RAM assembly. With a metric wrench, try to adjustment the press manually (from the main gear), see drawing RAM ASSEMBLY. The worm gear should be rotating freely. If you feel any restriction, do not operate & contact Technical Support.
Too many consequent hydraulic overload	Hydraulic overload can affect press clearance. When overloading the press, make sure to verify main clearance before operating the machine again.



Motor chain is too tight

Make sure the CHAIN from the motor adjustment is loose, not tight.





Figure 7.2.7.2 Azimuth AZ1 RAM

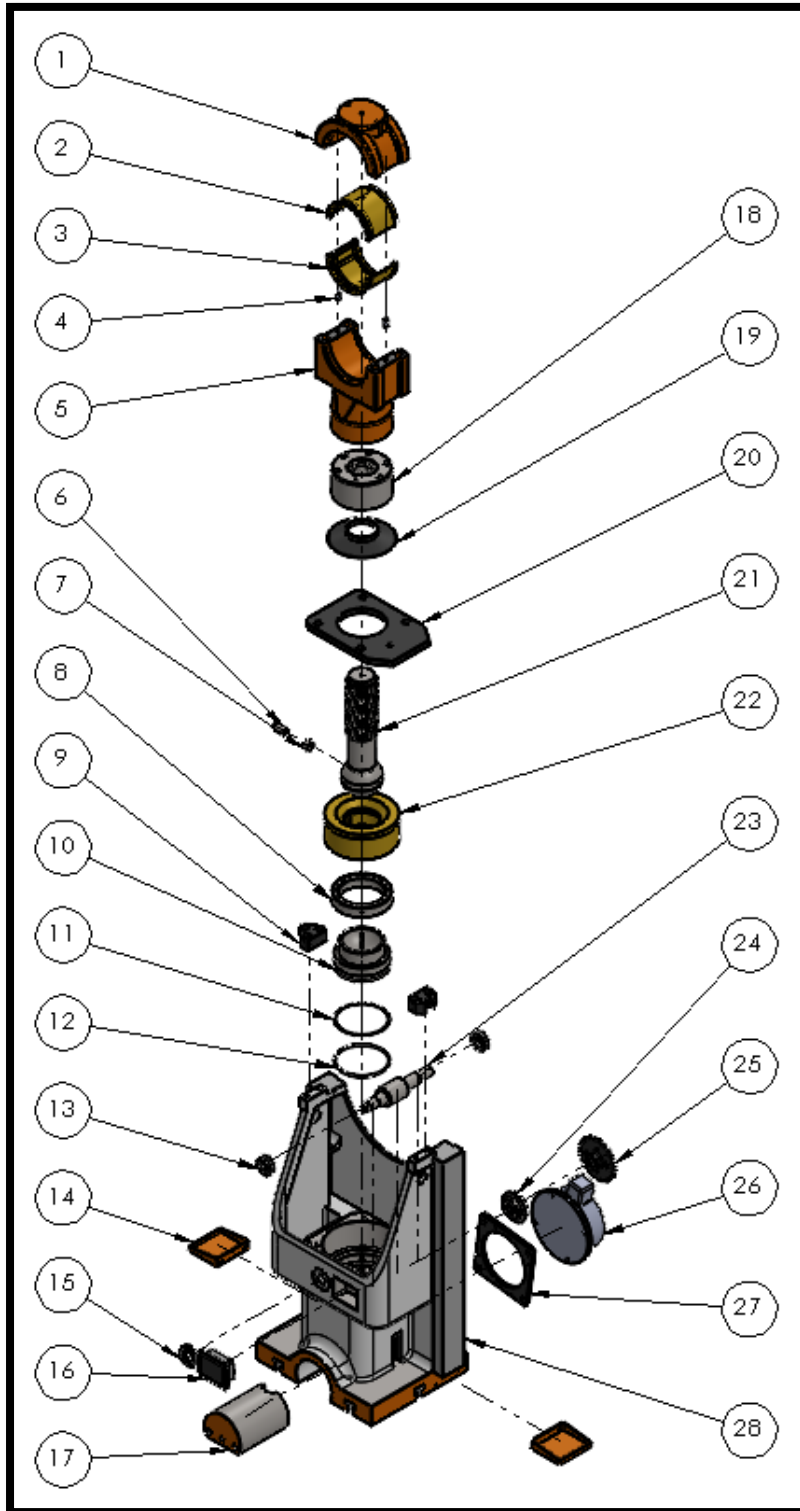



Provide press model number before ordering spart parts

ITEM NO.	PART NUMBER	DESCRIPTION	QTY.
1	29.1	PITMAN TOP BLOCK	1
2	136.1	BRONZE TOP BUSHING FOR PITMAN	1
3	136.2	BRONZE BOTTOM BUSHING FOR PITMAN	1
4	91595A737	POSITIONNING PIN FOR PITMAN	2
5	29.2	PITMAN MAIN BLOCK	1
6	157	KEY FOR BALLSCREW	1
7	157.1	RING FOR PITMAN KEY	1
8	23.3	BALL SEAT RETAINER	1
9	851	PISTON LINK TO RAM	2
10	25	BALL SEAT	1
11	23.1	RAM BALL SEAT RING	1
12	23.2	RAM BALL SEAT O-RING	1
13	6680K17	Angular-Contact Ball Bearing	2
14	807	GREASE TRAY	2
15	802	RAM OIL SIGHT	1
16	403	SHUT HEIGHT INDICATOR	1
17	24	CLAMP BLOCK FOR RAM	1
18	28	CLAMP BLOCK	1
19	23.4	PITMAN GASKET	1
20	200.17	PITMAN RETAINING PLATE	1
21	27	BALL SCREW PITMAN	1
22	26	PITMAN CUP ADJUSTMENT GEAR	1
23	177	WORM-GEAR SHAFT	1
24	845	SPUR GEAR SEAL	1
25	250.1	ENCODER SPROCKET FOR AZ60	1
26	126	ELECTRIC MOTOR FOR 60T RAM	1
27	69	MOTOR BRACKET	1
28	23	AZ60 RAM FRAME	1

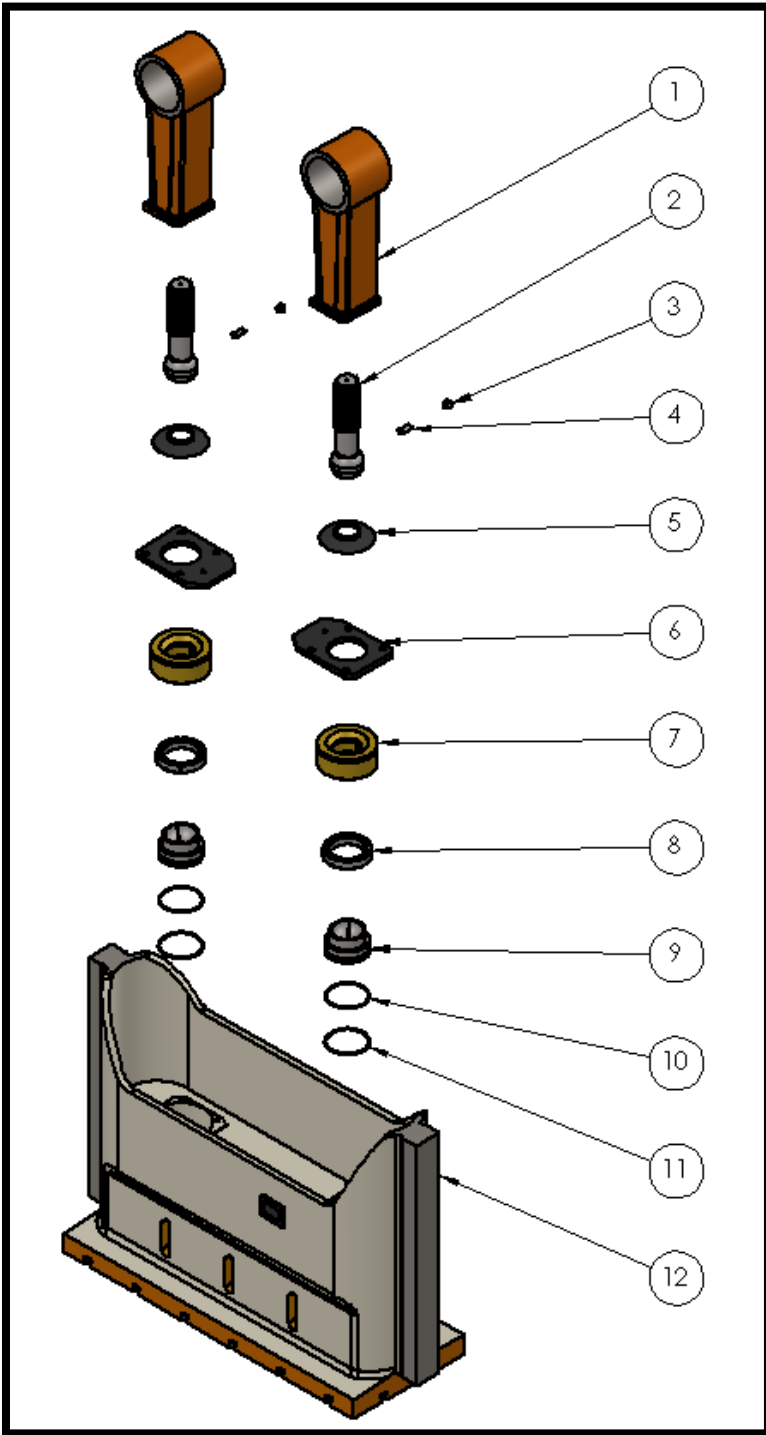



ITEM NO.	PART NUMBER	DESCRIPTION	QTY.
1	029	PITMAN BLOCK	2
2	027	BALL SCREW PITMAN	2
3	157.1	RING FOR PITMAN KEY	2
4	157	KEY FOR BALLSCREW	2
5	023.4	PITMAN GASKET	2
6	200.17	PITMAN RETAINING PLATE	2
7	026	PITMAN CUP ADJUSTMENT GEAR	2
8	023.3	BALL SEAT RETAINER	2
9	025	BALL SEAT	2
10	023.1	RAM BALL SEAT RING	2
11	023.2	RAM BALL SEAT O-RING	2
12	023	RAM FRAME	1



This section covers the maintenance notes.

Description	Section (CTL + CLICK BELOW)	Date of inspection	Notes from Maintenance
Verify press parallelism	<u>Checking Ram and Bed Parallelism</u> Checking Ram and Bed Parallelism		
Verify press overall clearance	<u>Checking Main bushing clearance & ball-screw clearance</u>		
Verify motor belts	<u>Adjusting Belt Tension</u>		
Verify hydraulic overload pumpHydraulic Overload protection (HOLP)	<u>Hydraulic Overload protection (HOLP)</u>		
Changing oil	<u>Changing oil</u>		



1 - FRONT LEFT CORNER	0.000"
2 – FRONT RIGHT CORNER	
3 – LEFT BACK CORNER	
4 – RIGHT BACK CORNER	

- NO APPARENT SCRATCH ON RAM’S AFTER 2,000 STROKES
- RAM RANGE IS WITHIN SPECS (see specs)
- RAM ADJUSTMENT IS DONE EASILY WITHIN RANGE (BALL-SCREW & PITMAN THREADS)

MAIN BUSHINGS & OVERALL CLEARANCE

- NO APPARENT SCRATCH OR HEATING WHILE RUNNING

Overall Clearance	
-------------------	--

VERIFIED BY _____



AIR-CLUTCH & BRAKE

- INTERNAL SEAL NOT DAMAGED (NO APPARENT LEAK)
- AIR-CUTCH PRESSURE SET AT 85PSI
- VERIFIED BRAKE LININGS IS LOOSE WHEN CLUTCH IS ENGAGED (Dry friction clutch ONLY)
- VERIFIED CLUTCH LININGS IS LOOSE WHEN BRAKE IS ENGAGED (Dry friction clutch ONLY)



Machine tested under load in continuous (@ minimum 500 strokes)

TABLE 7.2.7.4 HYDRAULIC OVERLOAD SETTING VALUE & MACHINE LOAD TESTING

Machine tested under load	METRIC TONS
Number of cycles	5000 strokes
HYDRAULIC OVERLOAD PROTECTION ADJUSTMENT	tons

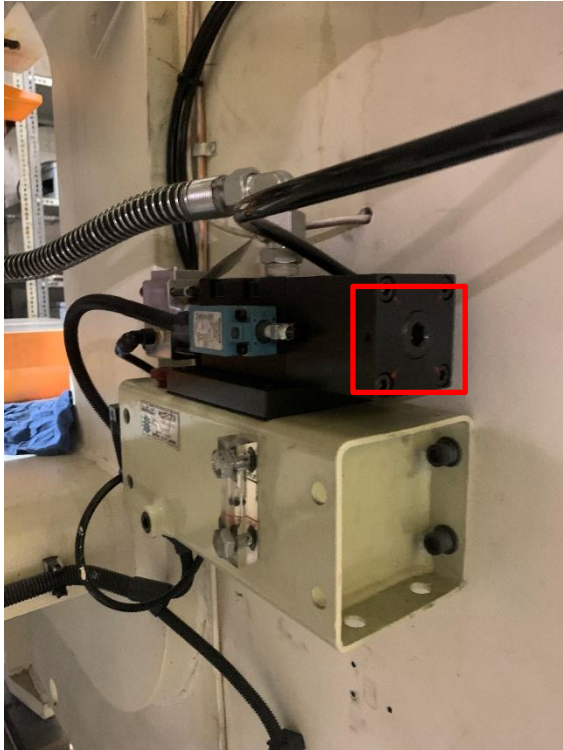

Do not attempt adjusting hydraulic overload without a certified technician. This can result in severe damage to the machine.

Rotating the screw clockwise will increase value of the actual overload of the machine.

Rotating the screw counter clockwise will reduce value of the actual overload of the machine.

Figure 7.2.7.4 Hydraulic overload protector

VERIFIED BY



Oiling system fittings do not leak

Oiling system works at power-up

Idling time (min)	
Oiling cycle (sec)	

VERIFIED BY _____



- GUARDING NOT RUBBING AGAINST MAIN COMPONENTS
- GUARDING IS PROPERLY INSTALLED
- Guarding meets CSA safety distance

VERIFIED BY

Bolster plate

- Confirm no parts on the bolster surface; screws of bolster already be fastened
- Planeness tolerance is within allowance

Die height adjustment (motorized)

- check wiring of die adjusting motor
- confirm enough lubrication for worm and worm gear
- check die height indicator function
- Motor not forcing or “buzzing” while doing adjustment

Main motor drive

- Check motor shaft and belt wheel with no loose, crack, wear or deformation







Warranty plan on part-revolution presses model 6-AC TO 44-AC, AZ1 MODELS, AZ2 MODELS, AZ-S1 MODELS, AZ-S2 MODELS

Warranty plan on part-revolution presses model 6-AC TO 44-AC, AZ1 MODELS, AZ2 MODELS, AZ-S1 MODELS, AZ-S2 MODELS.

Years on air-clutch & electrical components

3

Azimuth machinery warrants to the original purchaser, to repair or, at AZIMUTH MACHINERY'S sole option, replace any major frame, crown, bed, upright or slide (machine casting or weldment), Air-clutch, seals & ALL Electrical components (greaser, oiler, motor, main controller, press encoder) after examination by AZIMUTH MACHINERY's properly authorized representative, to be defective in material or workmanship under normal use within three years or, if sooner, **6,000 hours** of running time after the original date of shipment from the AZIMUTH MACHINERY plant.

Does not include labor¹ or diagnostic work. The original purchaser will be responsible for travel costs and expenses.

Years mechanical parts warranty

2

Azimuth machinery warrants to the original purchaser, to repair or, at AZIMUTH MACHINERY'S sole option, replace any parts that are found defective(Ballscrew, pitman(s),crankshaft(s), slide, GIBS, RAM) after examination by AZIMUTH MACHINERY's properly authorized representative, to be defective in material or workmanship under normal use within three years or, if sooner, **4,000 hours** of running time after the original date of shipment from the AZIMUTH MACHINERY plant.

Does not include labor or diagnostic work. The original purchaser will be responsible for travel costs and expenses.

Year warranty on Hydraulic & others air-components

1

Azimuth machinery warrants to the original purchaser, to repair or, at AZIMUTH MACHINERY'S sole option, replace any parts that are found defective(hydraulic clampers (if furnished), hydraulic components, motors, air-counter balance & all others air components & hydraulic components) after examination by AZIMUTH MACHINERY's properly authorized representative, to be defective in material or workmanship under normal use within three years or, if sooner, **3,000 hours** of running time after the original date of shipment from the AZIMUTH MACHINERY plant.

Does not include labor or diagnostic work. The original purchaser will be responsible for travel costs and expenses.

¹ 150\$/hour + traveling expense.









