



Presses & Automation – Since 1975

Instruction Manual Servo feeder





AZIMUTH MACHINERY
T. 450 632 8080 • sales@azimuthpress.com • www.azimuthpress.com
6040 Route 132, Ste-Catherine, Quebec, Canada, J5C 1B6



Azimuth Servo Feed Instruction manual

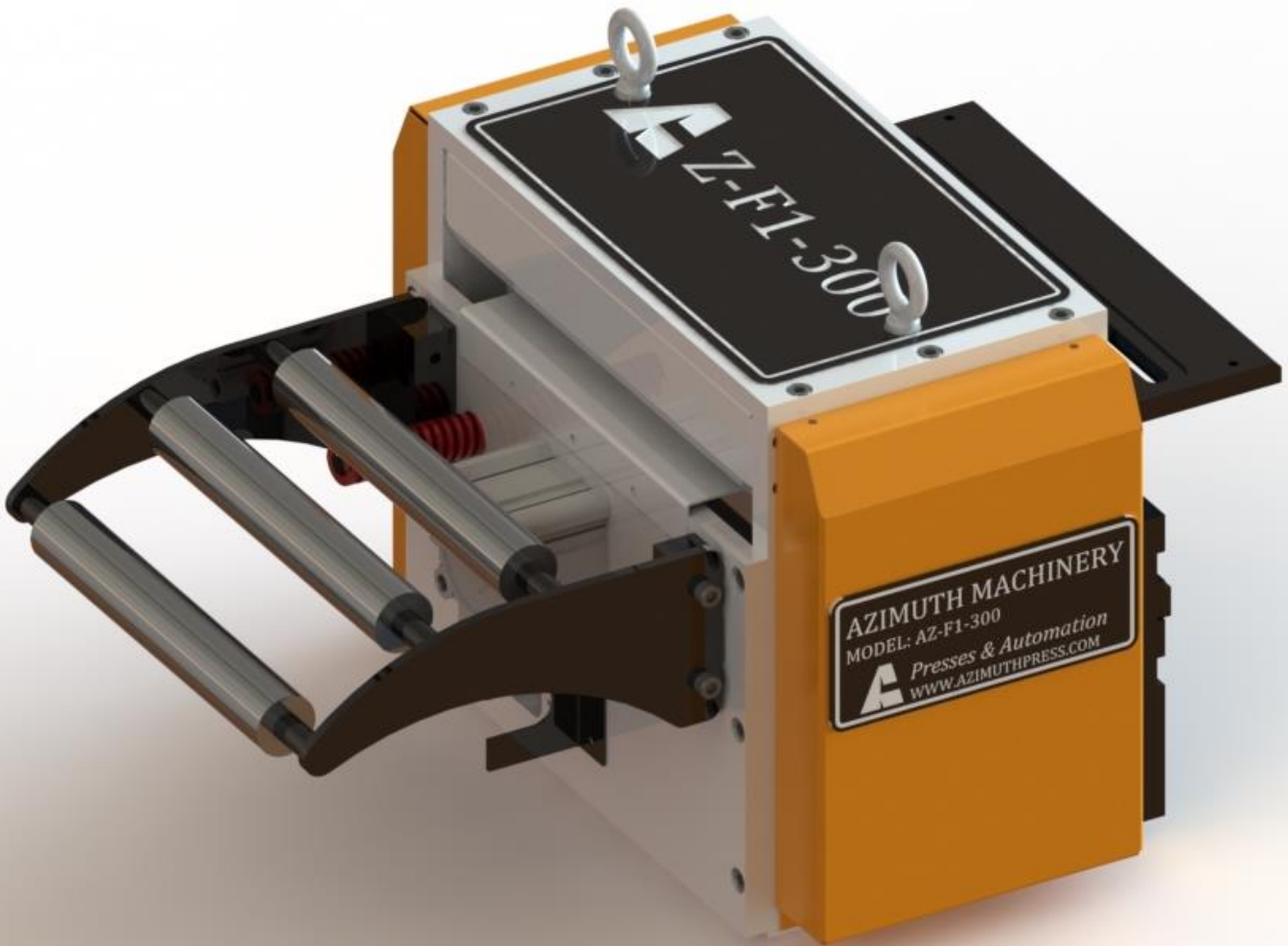



Table of Contents

1.	Word of Caution	4
2.	Installation.....	5
2.1.	Adjusting the Feeder Pass Line Height	5
2.2.	Roller Pressure and Spacing Adjustment	7
2.3.	Using the Pneumatic Pilot Release	8
2.4.	Manual Release	9
2.5.	Automatic Release.....	9
2.6.	Feeder specification	10
2.7.	Adjusting Belt Tension and Checking Belt Life	11
2.8.	Belt Tensioning	12
2.9.	Belt Replacement	12
3.	Electrical Control	13
3.1.	Main Menu	13
3.2.	Job Screen.....	14
3.3.	Components of a Job.....	15
3.4.	Manual Mode	16
3.5.	Alarms.....	18
3.6.	Maintenance Screen.....	20
3.7.	Uncoiler (Optional)	21
3.8.	Feeder Signals & Press Communication	22
4.	Maintenance.....	23
4.1.	Machine routine maintenance needs	23
4.2.	Machine troubleshooting instructions	24
	APPENDIX	26
	APPENDIX I: AZ-FX SERIES DRAWINGS	26



1. Word of Caution

- ⚠ This machine is rated for **208V/60Hz** in star configuration. Make sure to properly connect the machine.
- ⚠ Before using the machine with material, make sure to perform a visual inspection and try to cycle it 5 times to verify that nothing has been damaged during transport (guarding system, etc.)
- ⚠ Never operate this machine until you've read & understood that this machine is dangerous. Placing your hands or any part of your body in this machine could lead to serious injuries or death.
- ⚠ Never operate this machine without the use of a guard or safety device that will always protect you from injuries.
- ⚠ Never work on this machine unless the power is turned off and locked.

***** Never put your hands in the machine unless the power is turned off and locked out *****



2. Installation

This section covers the mechanical set-up of the servo-driven feeder. Please make sure to fully understand these instructions before attempting to make mechanical adjustments to the machine. All servo feed products drawings and dimensions are presented in Appendix I.

2.1. Adjusting the Feeder Pass Line Height

Adjusting the feeder pass line height is slightly different for direct-mount and rack-mount feeders. Each of these configurations have their own instruction below.

Direct Mount

When the feeder is directly mounted to the press’s bolster plate using the provided mounting plate, use the height adjustment screw to make any change to the feeder pass line height.

Please note that the screw offers a limited pass line height adjustment. However, the provided mounting plate offers different mounting hole sets for higher or lower pass lines.

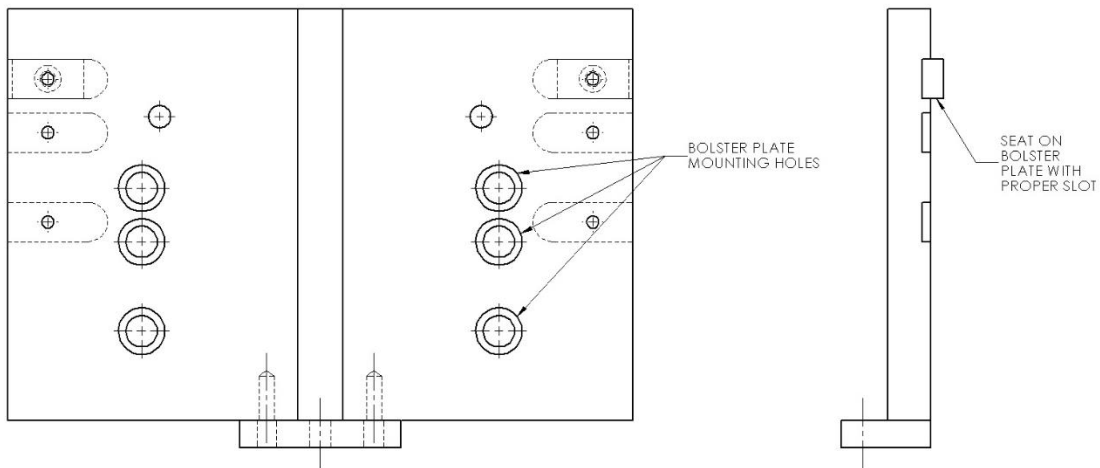

Figure 1: Feeder mounting plate



Rack Mount (Optional)

When the feeder is mounted on an Azimuth Feeder Rack, the pass line height can be adjusted by a wider range, using the built-in screw jack to raise or lower the feeder on the rack. Turning the handle will change the height of the pass-line. A height ruler is included on the feeder rack to approximate the current pass line height.

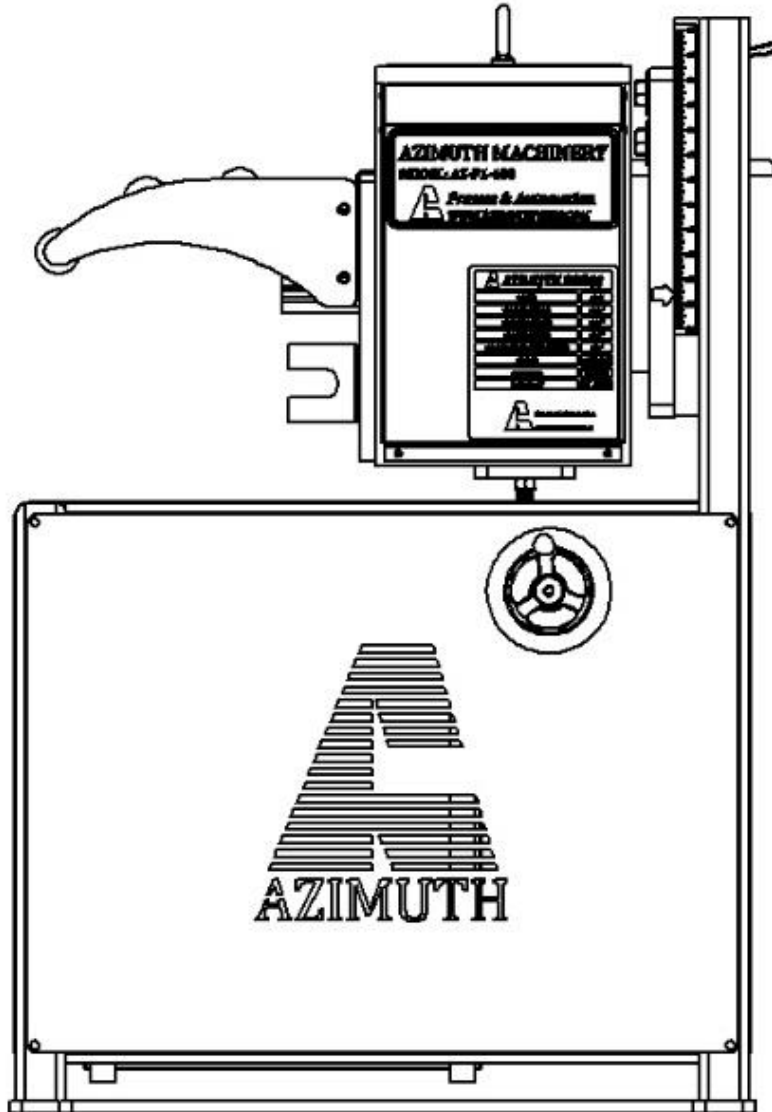

Figure 2: Rack-mounted feeder



2.2. Roller Pressure and Spacing Adjustment

To adjust the pressure and/or the spacing of the rollers on the sheet metal strip, please use the two threaded studs and nuts to compress or decompress the springs.

Before attempting to change the tension of the springs, please loosen the jam nuts that sit against the main hex nuts, then turn the hex nuts evenly. **Failure to tighten both springs evenly may result in sideways feeding of the sheet metal.**

When the desired pressure and spacing are reached, tighten the jam nuts against the main hex nuts to lock the adjustment in place.

Adequate pressure is reached when there is no slippage of the sheet metal strip. Excessive pressure may cause deformation of the sheet metal.

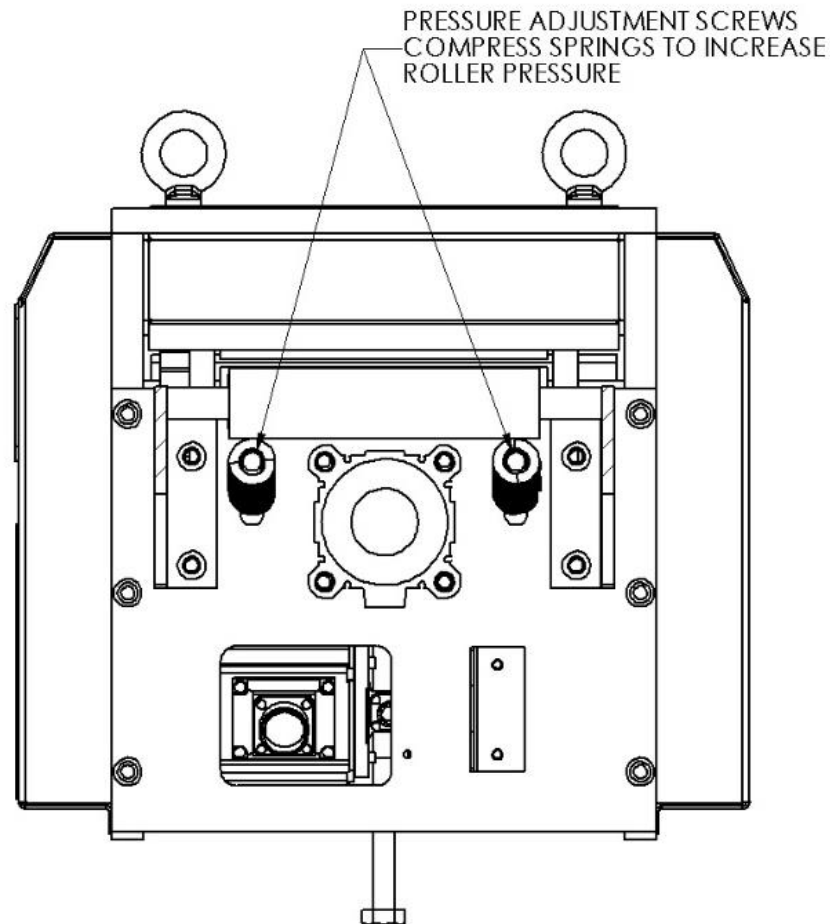

Figure 3: Roller pressure adjustment



2.3. Using the Pneumatic Pilot Release

The feeder is equipped with a pneumatic cylinder to release the pressure off the rollers.

The air pressure supplied to the cylinder **must not exceed 60 psi** (0.4 MPa). **Any higher pressure may cause damage to the feeder.**

If your air supply pressure is higher, please restrict flow completely using the feeder's pressure regulator before plugging it into the feeder, then adjust the regulator until the pressure gauge reads around 0.4 MPa (60 psi).

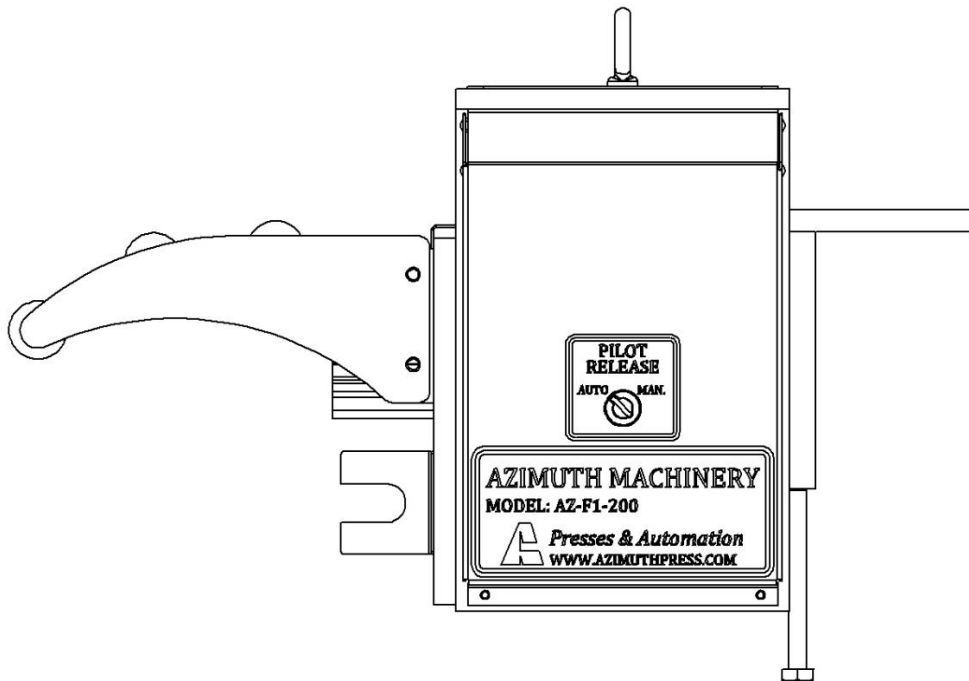

Figure 4: Pilot release mode switch



2.4. Manual Release

Turning the pilot release switch to manual mode will override the signal from the HMI and will disengage the rollers' pressure, allowing you to change sheet metal coils and set-up new material. Once you are done setting up your feeder with your new coil, turn the switch back to AUTO to enable automatic pilot release.



Figure 5: Manual pilot release

2.5. Automatic Release

Automatic pilot release mode allows the HMI to send a signal to the pilot release cylinder to disengage the rollers' pressure between feed cycles when the press is punching the metal strip.



2.6. Feeder specification

When setting up a new coil, set the pilot release to manual mode. Feed the new material through the feeder by hand and switch the pilot release back to AUTO.

Adjust roller pressure following the instructions from section 2.2.

Model→ Parameter↓	Unit	AZ-F1-200	AZ-F1-300	AZ-F1-400	AZ-F1-600	AZ-F1-800
Coil Width	inch	7 7/8	11 13/16	15 3/4	23 5/8	31 1/2
Thickness MIN	inch	0,01				
Thickness MAX	inch	0,14				
Rolls diameter	inch	3,55				
Pilot release		Pneumatic				
MAX SPEED	inch	16 inch/s				
Std. Voltage		208VAC-3PH/480VAC-3PH				
Motor Power		2KW				
Air		40 PSI				

Table 1: Feeding width capacity in inches

Thickness gauge	AZ-F1-200	AZ-F1-300	AZ-F1-400
28	8.00	12.00	16.00
26	8.00	12.00	16.00
22	8.00	12.00	16.00
20	8.00	12.00	16.00
18	6.25	10.00	14.00
16	4.75	8.00	12.63
14	4.00	6.00	10.00
12	3.13	4.00	8.00
11	2.00	2.38	4.75
10	1.13	1.50	2.38



2.7. Adjusting Belt Tension and Checking Belt Life

The servomotor powers the rollers with a timing belt and timing pulleys. To ensure that the system runs well, it is important to periodically check the belt for excessive slack or cracks in the rubber.

Always make sure the power is off and locked before performing maintenance on the belt.

To access the timing belt compartment, undo the four bolts that hold the side guard without a pressure gauge, and remove the guard.

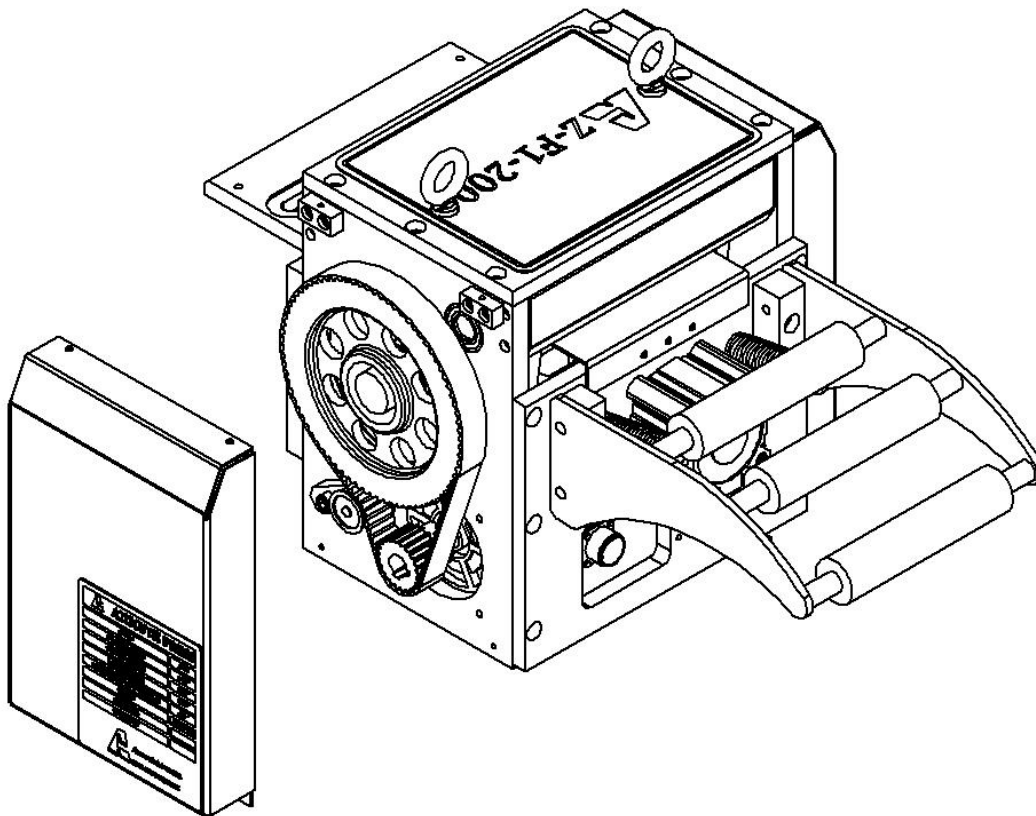

Figure 6: Timing belt compartment



2.8. Belt Tensioning

Belt tension should be checked periodically and adjusted when needed using the feeder's belt tensioner.

To put tension back in the belt, loosen the two bolts that hold the tensioner in place and push it against the timing belt.

When the tension is sufficient on the belt, tighten the two bolts of the tensioner.

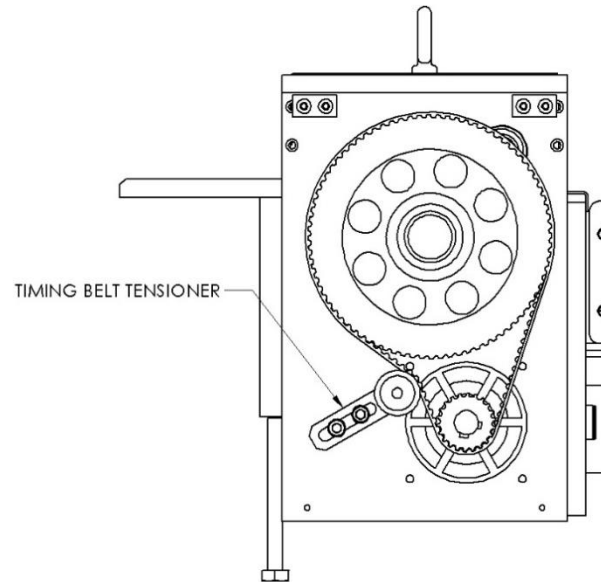

Figure 7: Belt tensioner

2.9. Belt Replacement

When the belt presents clear sign of wear or damage, it is time to replace it. A cracked belt is more prone to snapping and this will cause the feeder to stop functioning. The replacement part number is **HTD 776-8M-30**.

To replace the timing belt, first loosen the two bolts on the belt tensioner, then pull the tensioner back. Remove the old timing belt and put on the new one. Push the tensioner against it and tighten the two bolts when sufficient tension is reached.



Figure 8: Replacement timing belt

Always put the side guard back on the feeder before operating it. The timing belt presents pinch points and could lead to injury.



3. Electrical Control

3.1. Main Menu

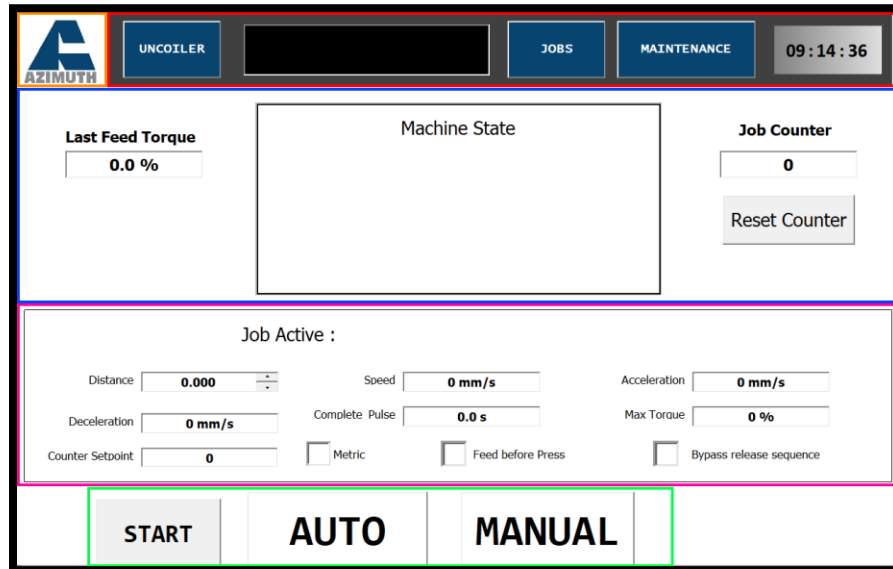

Figure 9: Main menu

Take note that the following electrical instructions may vary depending on the client personalized application.

You can always access the main screen from the navigation bar up top by pressing on the [Azimuth logo](#).

The [navigation bar](#) allows you to access the menu for the uncoiler, alarms, the programmable jobs menu, and the maintenance screen which allows you to change advanced settings. Note that [a password is required](#) to access the maintenance screen.

[Last feed torque](#) displays what the torque was for the last feed executed, note that this *does not include manual jogging or micro steps*. The [machine state](#) will display what the feeder is currently doing. The [job counter](#) increases every time a feed is executed.

You can also view and change information about [the current job](#), note that changing information here *will not save it to the current job*.



The **bottom bar** allows you to change the mode from auto and manual and also serves to change screens. Pressing on AUTO from the main screen will change to AUTO mode, pressing MANUAL from the manual screen will change to MANUAL mode. Note that both modes will reset, and you won't be able to toggle back, *when an alarm is active*. The start button allows you to start the machine when the feeder is set at feed before press.

3.2. Job Screen

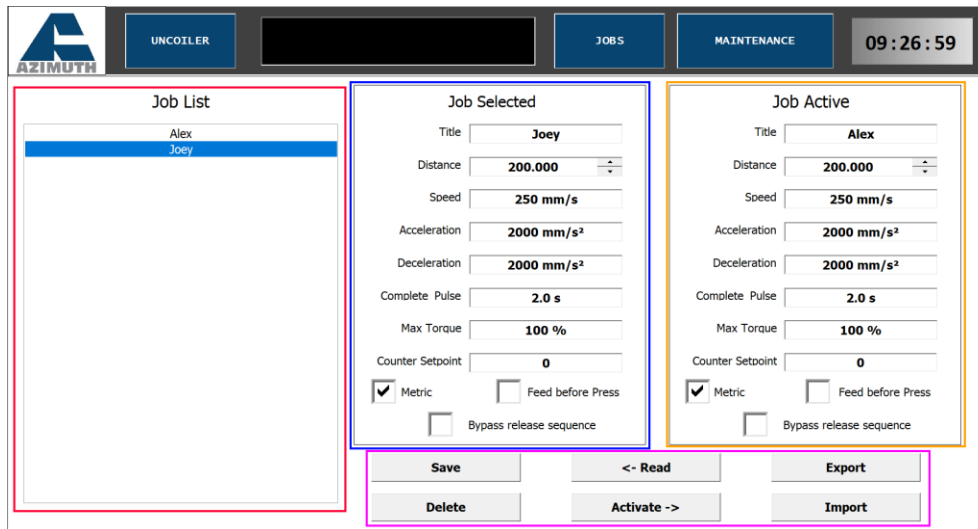

Figure 10: Job Screen

The **job list** shows the job that are *saved in the machine*.

The **selected job** shows the job which was selected in the list. If you press on the “Alex” job in the list, it will show its content.

The **active job** is the one which is currently in use by the feeder. The job selected merely shows you the content of the saved job.

The section below shows you actions that you can take on a job.

Save takes the job currently selected and saves it to the list. To **create a new job**, you must change the title and then save it.

Delete removes the job selected from the list *forever*. There is *no way to recover it* except if it was exported.



Read will take the active job and move it into the selected job, but it will not save it into the list.

Activate makes the current selected job into the active job.

Export will create a file on the HMI or on the USB stick that represents the job. This allows you to make backups.

Import will import a job that was exported back into the job list.

3.3. Components of a Job

Title	Joey
Distance	200.000
Speed	250 mm/s
Acceleration	2000 mm/s ²
Deceleration	2000 mm/s ²
Complete Pulse	2.0 s
Max Torque	100 %
Counter Setpoint	0
<input checked="" type="checkbox"/> Metric	<input type="checkbox"/> Feed before Press
<input type="checkbox"/> Bypass release sequence	

Figure 11: Job components

Title: The name of the job.

Distance: The distance the feeder will advance. This is in metric if metric below is selected.

Speed: This is the speed at which the feeder will move. Will always be metric.

Acceleration: How quickly the feeder will reach its speed. Will always be metric.



Deceleration: How quickly the feeder will stop. Will always be metric.

Complete Pulse: After every feed cycle a pulse will be given corresponding to the amount of time give here. Check for “Feed Complete” output on the electrical schema.

Max Torque: Represents the force in percentage that the motor is allowed before giving an alarm. Note that there is also *a max torque in the maintenance menu* that applies in manual mode.

Counter Setpoint: When the feeder reaches the counter setpoint then it will stop. Leave at zero to disable.

Metric: Check when you want the recipe to be in metric. Note that this only applies to the recipe, *to change the overall unit* you need to go to the maintenance menu. Be warned that checking metric **will not automatically convert the distance**; this needs to be done manually.

Feed before press: Selects whether the feeder starts the press or if the press starts the feeder.

Bypass release sequence: Bypasses the release part of the sequence, allowing the feeder to operate without releasing the pilot.

3.4. Manual Mode

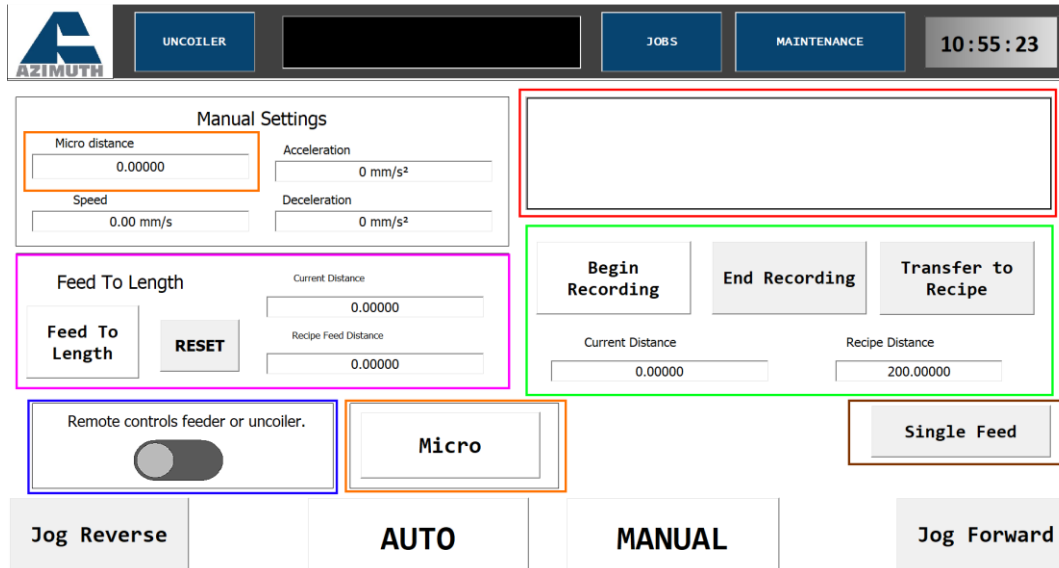

Figure 12: Manual mode explanation

NOTE: Manual mode must be selected for all of its controls to be accessible.



Feed To Length allows you to feed forward, but not past the total distance found in the recipe. To activate the feed to length mode then press the button and it will change color, the current distance will change from -1 to 0. Keep in mind that feed to length can go further than demanded, be careful and set a low acceleration and speed. You cannot micro step when using feed to length.

The **upper right blank box** will show state messages of the feeder, what the feeder is currently doing.

Recordings allow you to **record a distance** regardless of whether you've jogged forward or backwards. By pressing on the begin recording button the current distance will change to 0. You may then jog as you wish. Once you press end recording the total distance the feeder has moved forward will freeze and you can then transfer it to the active recipe using the button.

Micro-stepping can be activated **with the Micro button**. The feeder will then move the micro distance instead of jogging continuously when you press the button. Micro mode will be reset when selecting feed to length.

You can control whether the wireless remote moves the **uncoiler or the feeder**, should the machine have an uncoiler.

You can **execute a single feed** by maintaining the button for one second and then the entire time the feeder is moving.



3.5. Alarms

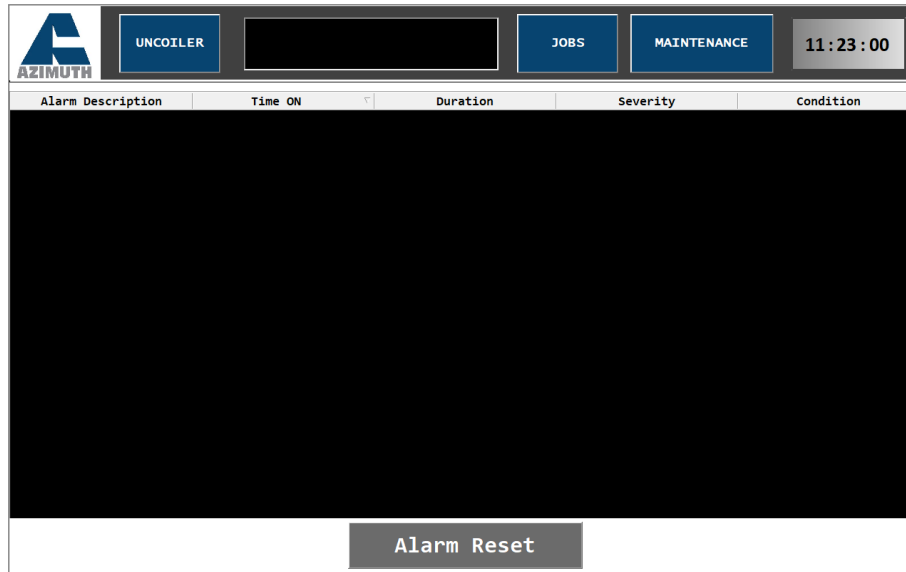

Figure 13: Alarm screen

The alarms screen will display alarms and allow you to reset them. Note that if the press gives out a fault signal, then the press controller will need to be reset before the alarm on the feeder.



Table 2: List of possible alarms

Alarm	Possible Problem	Solution
Double Feed	The feeder received a feed signal while waiting for a reset or release signal.	Make sure the controller's output are properly configured and that all wiring is properly connected.
Feed Signal Lost	The feed signal was lost during feeding.	Make sure the cam angle settings for the feed are properly set on the press controller, or increase the speed of the feeder. Make sure that all wiring is properly connected.
Max Torque	The maximum torque set in maintenance (if in Manual) or in the recipe (if in Auto) has been reached.	Inspect the mechanics of the feeder and die to make sure nothing is blocking it from operating properly. Make sure the proper material is selected. The max torque value is set too low or the machine is forcing more than it should – set it higher. Make sure a recipe is selected upon start-up.
Pilot Manual	The pilot release is manually activated.	Turn the selector on the side of the feeder to the proper position
Press Fault	The press controller is giving an error.	Clear the fault with the press controller. Make sure everything is properly wired.
Safety Activated	A safety has been activated.	Check all E-Stops and doors. Verify proper wiring.
Servo Drive Error	An error with the servo drive has occurred.	Press reset and if the error comes back then lookup the error code on the drive inside of the panel and take appropriate measures.
Single Feed Error	Single feed button has not been maintained long enough.	Make sure to maintain the single feed button all the while the feeder is feeding.
Uncoiler Auto Error	Feeder was put in Auto but the uncoiler was not.	Always put the uncoiler in Auto mode before the feeder.
Uncoiler Pilot Error	The uncoiler pilot release is manually activated.	Turn the selector on the side of the uncoiler to the proper position
Uncoiler Overload	Uncoiler motor has been overloaded	Perform a mechanical inspection of the uncoiler to make sure nothing is blocking it.



3.6.Maintenance Screen

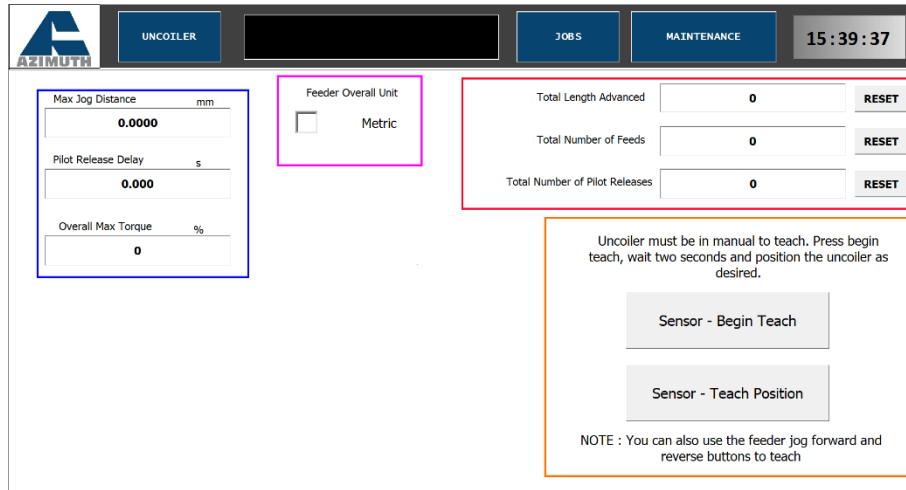

Figure 14: Maintenance menu

Max jog distance is the maximum the feeder can feed, in manual, while keeping the button pressed. If **the wireless remote loses its signal during a feed cycle**, it will **keep on feeding indefinitely**. This setting helps mitigate that issue by setting a limit. **Pilot release delay** is the time it takes for the pilot to go back down. It is to ensure that whenever a feed is triggered then the pilot is already back in the correct position. **Overall Max Torque** is the torque limit when the feeder is in manual mode.

Feeder Overall Unit is the unit of the feeder when it is in manual. By default, it is in inches.

There are **three counters which track different stats** on the feeder. How long the machine has fed, the total number of feeds executed and the number of pilot releases performed.

There is an experimental functionality that **allows you to reteach the setpoint position** of the sensor for the uncoiler. Use at your own risk for now.



3.7. Uncoiler (Optional)

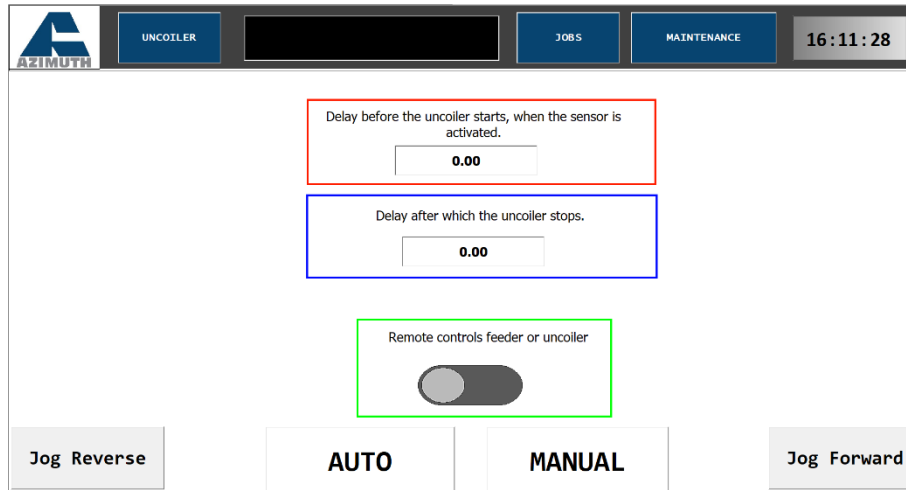

Figure 15: Uncoiler screen (Optional)

If your feeder comes with an uncoiler then you will be able to see this page. There are two delays that can be changed in order to modify how much the uncoiler uncoils the material and how quickly it starts. When the dancer bar below which the metal strip passes reaches a certain height then the uncoiler motor will start. This is controlled by a programmable sensor. The delay **before the uncoiler starts** when it has reached the sensor is the first parameter that can be set. The second is **how long the uncoiler motor will keep on going** after the sensor setpoint has been lost. There is an orange indicator light on the sensor itself.

You can choose whether the wireless remote controls **the feeder or the uncoiler** by toggling this switch.



3.8. Feeder Signals & Press Communication

Communication between the press and the feeder is done through six different signals. Four are sent from the press to the feeder, and two are sent from the feeder to the press.

The tables below explain the different signals that are exchanged between the feeder and the press.

Table 3: Signals from the press to the feeder

Feed	Initial signal that triggers a feed cycle from the feeder.
Reset	After a feed signal, the press must send a reset signal before the feeder can repeat.
Release	Releases the pressure on the material by operating a solenoid-controlled valve. This part of the sequence can be bypassed . Please visit section 2.3 for more detail .
Error	A fault condition has occurred in the press and therefore the feeder must stop. Please visit section 3.4 for more detail .

Table 4: Signals from the feeder to the press.

Complete Pulse	A pulse of programmable length given every time a feed is finished.
Error	A fault condition has occurred in the feeder and therefore the press must stop. Please visit section 3.4 for more detail .



4. Maintenance

4.1. Machine routine maintenance needs

- The condition in the air system (dryer/lubricator), daily oil checks should be made and the water must be emptied. Verify if there is a leak and the pressure is normal.
- Before working with the machine, operators must check all the working parts, should do the checks against the possibility of loosening and dismantling due to the vibrations occurring during feeding. Uncommon sounds are a good sign of malfunction.
- Periodically lubricate the bearings according to the maintenance chart. Most of them are sealed.
- Lubricate guidance rollers and screw shaft regularly for AZ-F3 models.
- Rollers must be cleaned before feeding the sheet.
- General maintenance and checks on the machine are mainly focused on abrasion and moving parts. Verify the following parts according to the maintenance chart. For further details, go to Appendix I.
 - AZ-F1
 - AZ-F1-XXX-2001-00, AZ-F1-XXX-2007-00, AZ-F1-XXX-2104, AZ-F1-XXX-3001-00, AZ-F1-XXX-3004-00, AZ-F1-XXX-3005-00 & AZ-F1-XXX-6003-00.
 - AZ-F2
 - AZ-F2-XXX-2001-00, AZ-F2-XXX-2007-00, AZ-F2-XXX-2008-00, AZ-F2-XXX-2009-00, AZ-F2-XXX-2104-00, AZ-F2-XXX-2011, AZ-F2-XXX-2012, AZ-F2-XXX-3001-00, AZ-F2-XXX-3004-00, AZ-F2-XXX-3005-00, AZ-F2-XXX-2008-00, AZ-F2-XXX-3102-00 & AZ-F1-XXX-6003-00.
 - AZ-F3 (INCOMING)

Table 5: Routine maintenance needs

Parts	Daily	Weekly	Monthly	Biannual
Conditioning oil control	✓			
Lubrication of bearings		✓		
Rollers cleaning	✓			
General maintenance and checks of the machine				✓



4.2. Machine troubleshooting instructions

For any requests regarding troubleshooting or issues with the machine, contact the following authorized personal.

For mechanical requirements:

- Charles Lefebvre charles@azimuthpress.com & Joey Trudeau joey@azimuthpress.com

For electrical or programming requirements:

- Alex Savoie alex@azimuthpress.com

The following general conditions must be followed.

- Check the machine and make sure that there is no damage when taking delivery of your machine. Please ask your dealer for replacement of shipping damage within 7 days starting the date of purchase, replacement requests are invalid after 7 days.
- Please check whether the accessories are missing while delivery of your machine. If there are any missing parts, please ask your dealer for the provision of the parts in question within 7 days from the date of purchase. Request you make after 7 days will not be considered.
- Make sure your machine is grounded and there are no voltage fluctuations on power supply.
- Failures caused by use of improper power connections are not covered by warranty of your machine. Repair of such failures will bring you financial burden.
- Do not try to attach external parts to each other's slots or their own slot the wrong way. Do all connections while the machine is off, do not try to attach or detach any parts while the machine is running.
- Do not interfere with software on the machine. Any modification to the software can be done if only Azimuth approves the request. Otherwise, it will cause your machine to be out of warranty.
- Make sure all connections to the machine are correctly made.
- Machine work surface must be flat, non-slip and solid.
- If our machine works with another machine than Azimuth ones, the manufacturer is not liable for any damage or work loss due to shock, moving around or vibrations in the event of overload of the other machine.
- Loading capacity of the machine must not be exceeded. Work overload will damage the machine and all components rotating.



- Make sure the machine is working as shown by the technical service during installation.
- Make sure there are no dust, slug or aluminum powder from sheet material sticking in the machine's rotating parts, every time you load a product roll.
- Only use our machines for sheet materials, our machines are designed for uncoiling, feeding and cutting sheet metals. They are not suitable for round or rectangle profiled materials.

Table 6: Troubleshooting instructions

Fault phenomenon	Failure cause	Elimination methods
There is a fixed direction feeding error	Feeding roller have not enough pressure	Increasing pressure
	Feeding length too long	Upper die strip material adverse puller phenomenon
	Feeding length not enough	Coil width and mold guide plate is appropriate? Or mold and feeder is straight line.
	Burrs or foreign bodies	Check the retaining plate and stripper for burrs or foreign bodies
Feed produced when unexpected errors	Feeder adjustment quantity of materials	Leveling machine and feeder whether match or leveling machine and feeder of middle distance and material arc height and appropriate punch turnover number
	Transmission gap is too large between roller and servo feeder	Will tighten gauge belt pulley
	Coil related conditions	Material thickness, width and length is in accordance with the standards?
Coil serpent	Coil thickness corresponding to the pressure	Adjust the pressure
	Coil width and keep-off wheel is not in proper place	Adjust the keep-off wheel
	On both sides of the roller and materials between high and low is not the same	Adjust on both sides of the roller to parallel
	Roller pressure is too large	The pressure drops
	Feeding roller and the material of sliding phenomenon	Check whether mold guide groove and feeder in line? The mold has waste that did not roll out? Materials have burrs and the phenomenon of card mode.



APPENDIX

APPENDIX I: AZ-FX SERIES DRAWINGS

In this appendix, you will find the spare parts and dimensions for all the AZ-FX servo feeder models. Note that the part numbers when ordering use the following template.

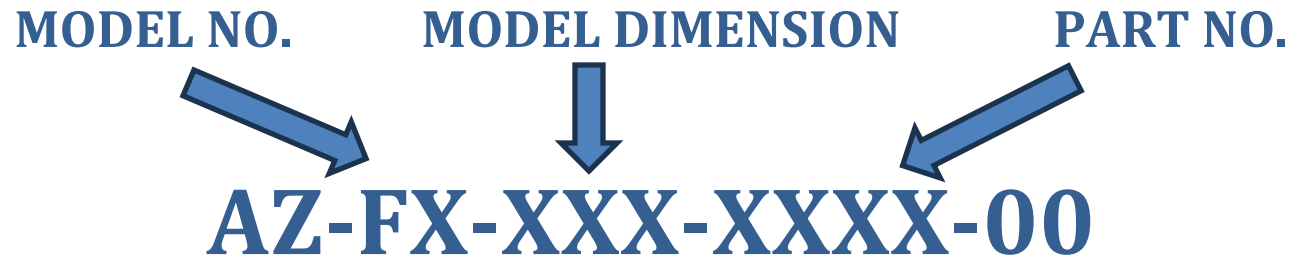





AZ-F1-XXX

AZ-F1-XXX SPARE PARTS:

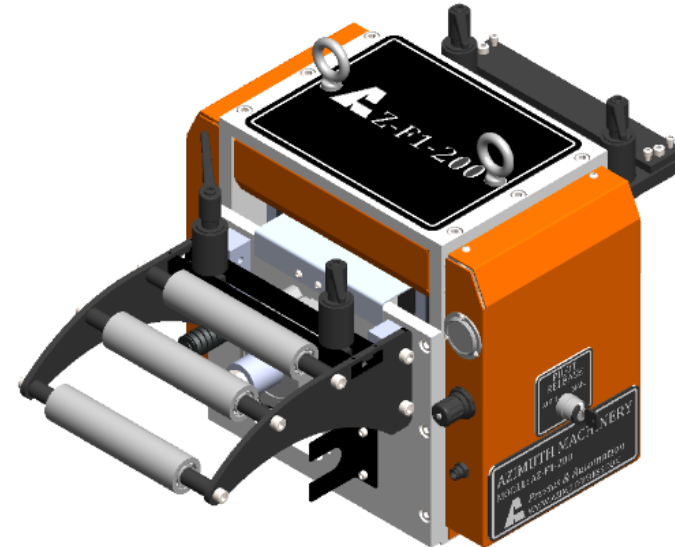
ITEM NO.	PART NUMBER	DESCRIPTION	QTY.
1	AZ-F1-200-0001-00	AIR CONNECTOR	1
2	AZ-F1-200-0002-00	SPECIFICATIONS PLATE	1
3	AZ-F1-200-0003-00	TOP DECO PLATE	1
4	AZ-F1-200-0004-00	FEEDER SIDE DECO PLATE	1
5	AZ-F1-200-0005-00	PRESSURE REGULATING VALVE	1
6	AZ-F1-200-0006-00	PILOT RELEASE PLATE	1
7	AZ-F1-200-0007-00	KEY SWITCH 2 POSITIONS	1
8	AZ-F1-200-0008-00	SINGLE SCALE PRESSURE GAUGE WITH STEEL CASE	1
9	AZ-F1-200-1000-00	FRAME	1
10	AZ-F1-200-2000-00	CRANKSHAFT ASSEMBLY	1
11	AZ-F1-200-3000-00	COUPLING SHAFT	1
12	AZ-F1-200-4000-00	ROLLER ASSEMBLY	1
13	AZ-F1-200-5000-00	WIDTH LIMITER	4
14	AZ-F1-200-6000-00	MOTOR	1
15	AZ-F1-200-7000-00	TENSIONER	1
16	AZ-F1-200-8000-00	ADJUSTING PLATE	1
17	AZ-F1-200-11000-00	ADJUSTING CYLINDER FOR THICKNESS	1

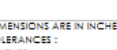

DESCRIPTION		FEEDER AZ-F1-200
PART NO		AZ-F1-200-0000-00
DRAWN BY	SCALE	1:1
DATE	MATERIAL	
RAW MATERIAL	QTY	1
TREATMENT	WEIGHT	

NOTE: BREAK ALL SHARP EDGES	
	
DIMENSIONS ARE IN INCHES	
TOLERANCES :	
ANGLES :	±1°
FRACTIONAL	±1/32
TWO PLACE DECIMAL	±.01
THREE PLACE DECIMAL	±.005
FOUR PLACE DECIMAL	±.001

	
AZIMUTH MACHINERY PRODUCE & ASSEMBLY 6040 ROUTE 132, STE-CATHERINE, QUEBEC, CANADA J5C 1B6	
PROPRIETARY AND CONFIDENTIAL THE INFORMATION CONTAINED IN THIS DRAWING IS THE SOLE PROPERTY OF AZIMUTH MACHINERY. ANY REPRODUCTION IN PART OR AS A WHOLE WITHOUT THE WRITTEN PERMISSION OF AZIMUTH MACHINERY IS PROHIBITED.	

2014_Engeneering1_Producer_Footer_AZ-F1-AZ-F1-AZ-F1-0001_Drawing

PAGE 1/1

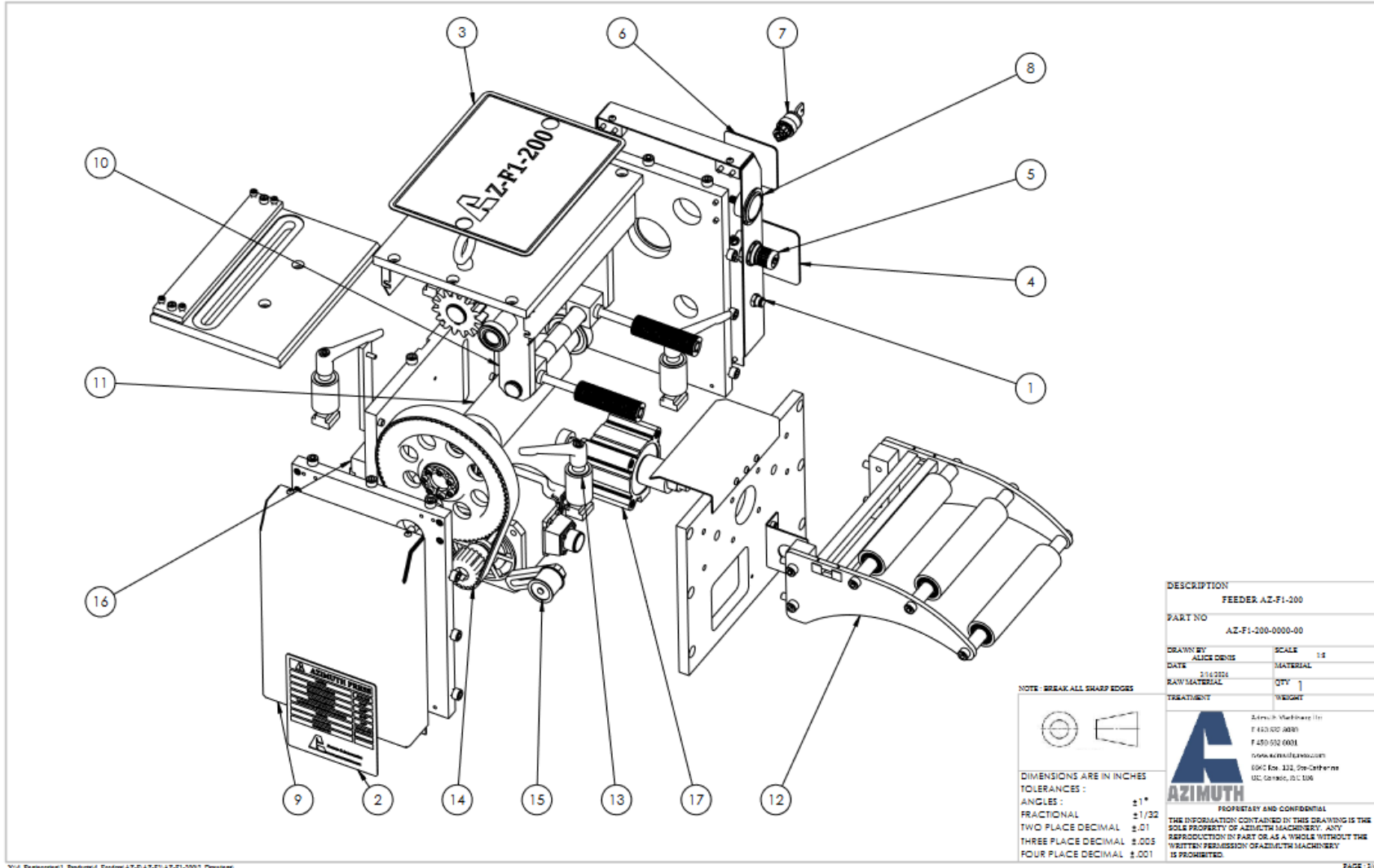



ITEM NO.	PART NUMBER	DESCRIPTION	QTY.
1	AZ-F1-200-1001-00	FRONT PLATE	1
2	AZ-F1-200-1002-00	TOP PLATE	1
3	AZ-F1-200-1004-00	SIDE PLATE	1
4	AZ-F1-200-1003-00	SERVO SIDE PLATE	1
5	AZ-F1-200-1011-00	AZ-F1 SIDE GUARD	1
6	B18.3.1M - 8 x 1.25 x 20 Hex SHCS -- 20NHX		2
7	B18.3.1M - 6 x 1.0 x 20 Hex SHCS -- 20NHX		20
8	B18.3.1M - 10 x 1.5 x 25 Hex SHCS -- 25NHX		6
9	B18.3.1M - 10 x 1.5 x 16 Hex SHCS -- 16NHX		8
10	B18.3.1M - 10 x 1.5 x 20 Hex SHCS -- 20NHX		6
11	B18.3.1M - 6 x 1.0 x 16 Hex SHCS -- 16NHX		2
12	B18.3.1M - 6 x 1.0 x 12 Hex SHCS -- 12NHX		2
13	B18.3.4M - 6 x 1.0 x 10 SBHCS --N		8
14	B18.3.4M - 6 x 1.0 x 6 SBHCS --N		3
15	AZ-F1-200-1005-00	BACK PLATE	1
16	AZ-F1-200-1006-00	BED PLATE	1
17	AZ-F1-200-1013-00	GUIDE PLATE	1
18	AZ-F1-200-1011-01	AZ-F1 SIDE GUARD	1
19	AZ-F1-200-1008-00	GUIDE	1
20	AZ-F1-200-1009-00	CLAMPING PLATE	1
21	AZ-F1-200-1012-00	FRONT GUARD	2
22	AZ-F1-200-1014-00	CABLE TIDY PLATE	1

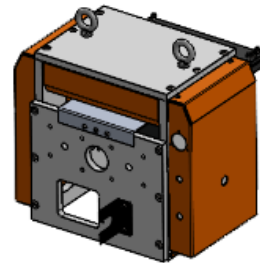
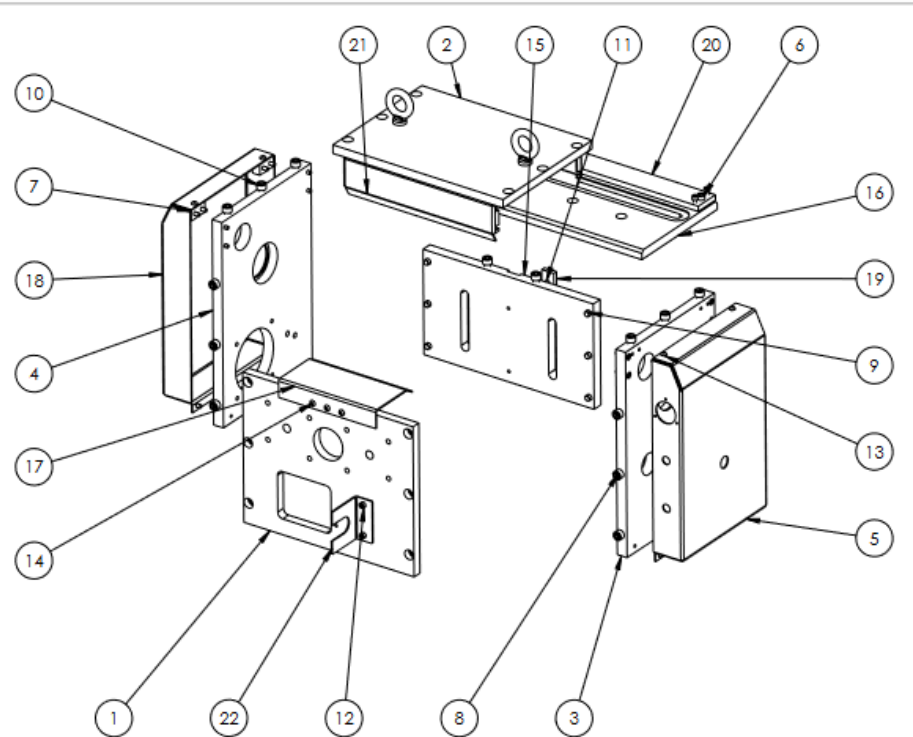

DESCRIPTION	
FRAME	
PART NO	
AZ-F1-200-1000-00	
DRAWN BY	SCALE
ALICE DENIS	1:1
DATE	WEIGHT
2/16/2024	
 Azimuth Machinery Inc. 1450 100 Avenue F 450 632 8081 www.azimuthpress.com 6040 Rue 132, Ste-Catherine QC, Canada, J5C 1B6	
PROPRIETARY AND CONFIDENTIAL THE INFORMATION CONTAINED IN THIS DRAWING IS THE SOLE PROPERTY OF AZIMUTH MACHINERY. ANY REPRODUCTION IN PART OR AS A WHOLE WITHOUT THE WRITTEN PERMISSION OF AZIMUTH MACHINERY IS PROHIBITED.	

X:\4_Engineering\1_Products\4_Produit\AZ-F1\AZ-F1-1000-00_Drawing



ITEM NO.	PART NUMBER	DESCRIPTION	QTY.
1	AZ-F1-200-2001-00	PRESSURE ADJUSTING ROLLER	1
2	AZ-F1-200-2002-00	PRESSURE LEVER PLATE	2
3	AZ-F1-200-2004-00	TOP	1
4	AZ-F1-200-2005-00	PIVOT SHAFT	1
5	AZ-F1-200-2006-00	BUSHING	2
6	AZ-F1-200-2007-00	BALL BEARING	2
7	AZ-F1-200-2010-00	PRESSURE ADJUSTMENT SHAFT	1
8	AZ-F1-200-2100-00	SPRING SHAFT	2
9	AZ-F1-200-2011-00	BEARING	1
10	AZ-F1-200-2012-00	SPUR GEAR	1

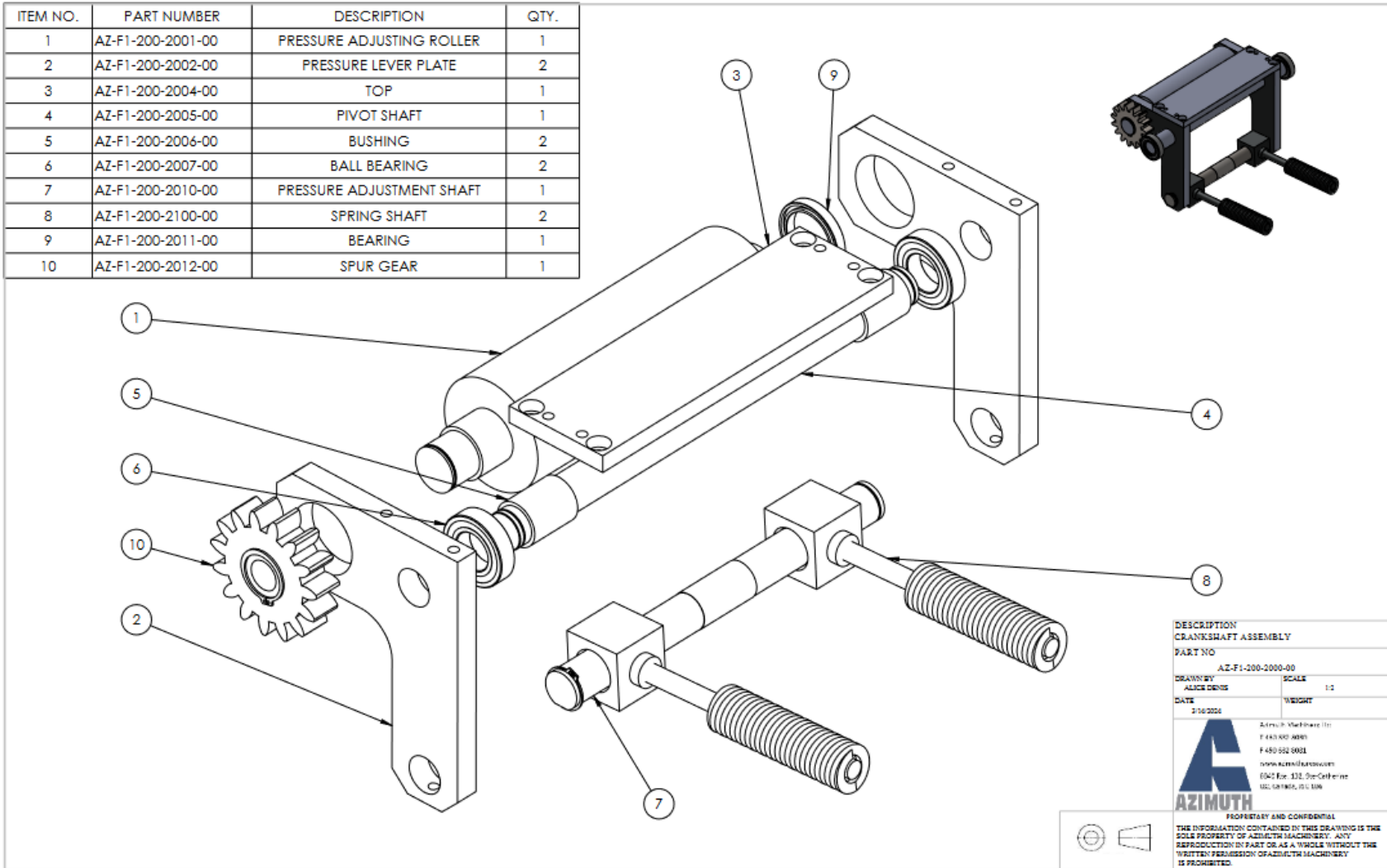

DESCRIPTION	
CRANKSHAFT ASSEMBLY	
PART NO	
AZ-F1-200-2000-00	
DRAWN BY	SCALE
ALICE DENIS	1:1
DATE	WEIGHT
2/16/2024	

Azimuth Machinery Inc.
 7 450 632 8080
 F 450 522 9821
www.azimuthpress.com
 6040 Rue 132, Ste-Catherine
 QC J5C 1B6, CANADA





PROPRIETARY AND CONFIDENTIAL
 THE INFORMATION CONTAINED IN THIS DRAWING IS THE
 SOLE PROPERTY OF AZIMUTH MACHINERY. ANY
 REPRODUCTION IN PART OR AS A WHOLE WITHOUT THE
 WRITTEN PERMISSION OF AZIMUTH MACHINERY
 IS PROHIBITED.

2024 Engineering1_Produced_Footer AZ-F1-AZ-F1-2000_00.Dwg

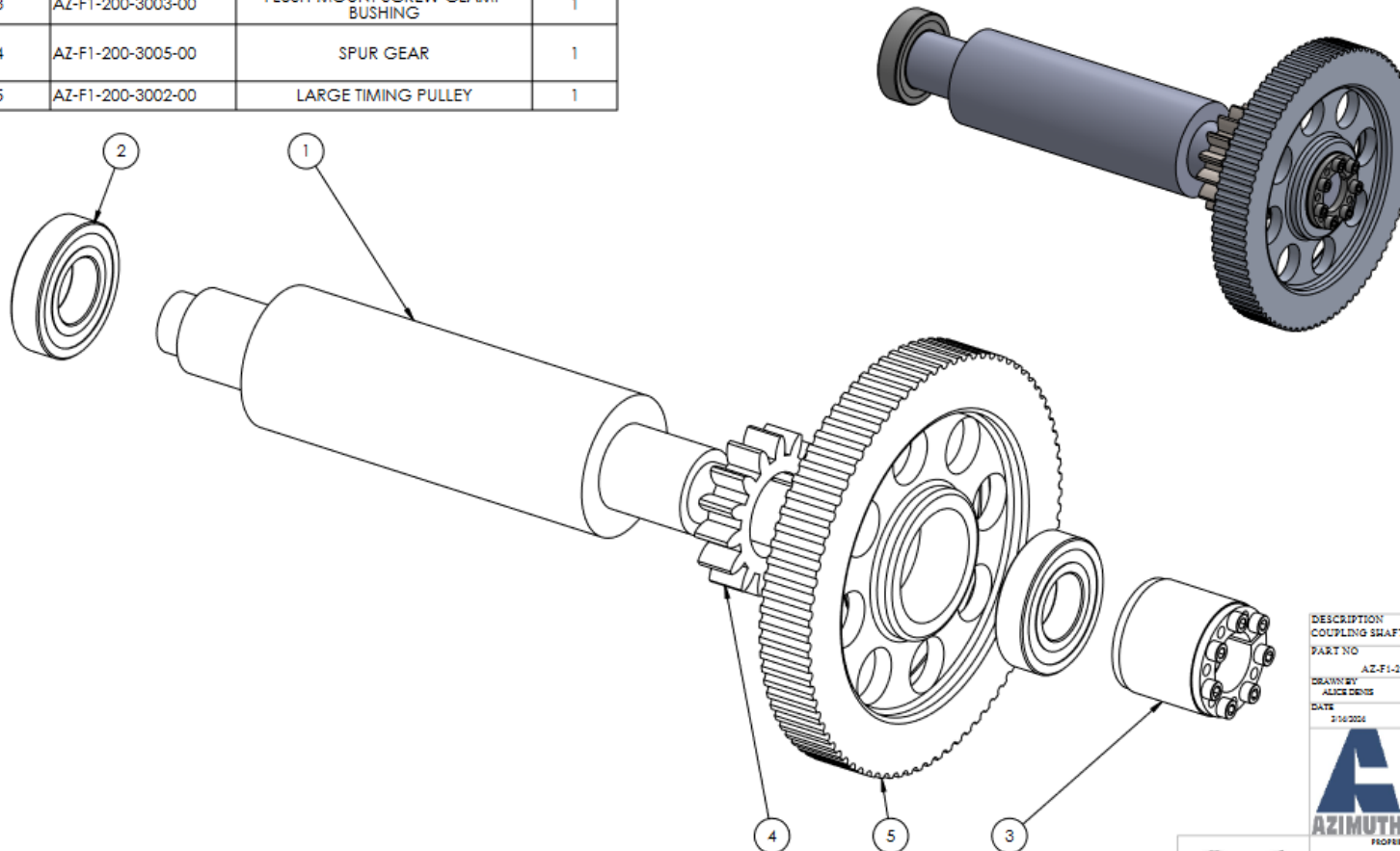

ITEM NO.	PART NUMBER	DESCRIPTION	QTY.
1	AZ-F1-200-3001-00	FIXED ROLLER	1
2	AZ-F1-200-3004-00	BALL BEARING	2
3	AZ-F1-200-3003-00	FLUSH-MOUNT SCREW-CLAMP BUSHING	1
4	AZ-F1-200-3005-00	SPUR GEAR	1
5	AZ-F1-200-3002-00	LARGE TIMING PULLEY	1





DESCRIPTION	
COUPLING SHAFT	
PART NO	
AZ-F1-200-3000-00	
DRAWN BY	SCALE
ALICE DESS	1:1
DATE	WEIGHT
2/16/2024	
 Address: 6040 Route 132 Ste-Catherine, QC J5C 1B6 Canada Tel: 450 632 8080 Fax: 450 632 8081 www.azimuthpress.com	
PROPRIETARY AND CONFIDENTIAL THE INFORMATION CONTAINED IN THIS DRAWING IS THE SOLE PROPERTY OF AZIMUTH MACHINERY. ANY REPRODUCTION IN PART OR AS A WHOLE WITHOUT THE WRITTEN PERMISSION OF AZIMUTH MACHINERY IS PROHIBITED.	

2016 Engineering 1, Product 6, Fusion AZ-FAD-F1-AZ-F1-2001, Drawing

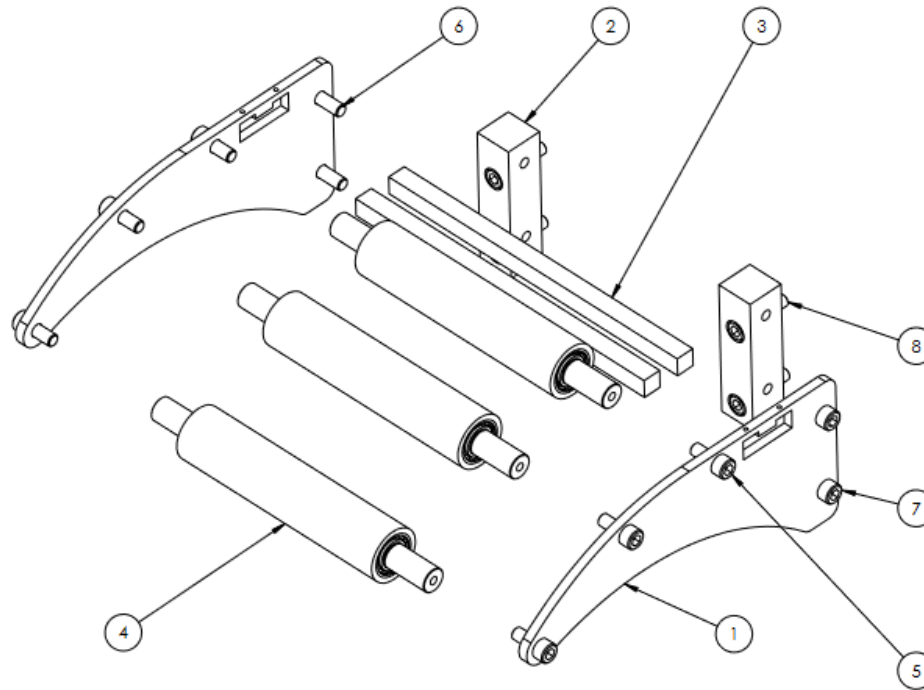
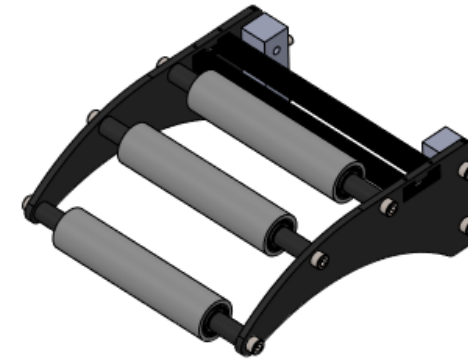

ITEM NO.	PART NUMBER	DESCRIPTION	QTY.
1	AZ-F1-200-4001-00	SIDE SUPPORT	2
2	AZ-F1-200-4002-00	ATTACH BLOCK	2
3	AZ-F1-200-4003-00	DISTANCE SUPPORT	2
4	AZ-F1-200-4100-00	ROLLER ASSEMBLY	3
5	B18.3.1M - 10 x 1.5 x 25 Hex SHCS -- 25NHX		6
6	B18.3.1M - 10 x 1.5 x 30 Hex SHCS -- 30NHX		2
7	B18.3.1M - 10 x 1.5 x 16 Hex SHCS -- 16NHX		2
8	B18.3.1M - 10 x 1.5 x 40 Hex SHCS -- 40NHX		4



DESCRIPTION	
ROLLER ASSEMBLY	
PART NO	
AZ-F1-200-4000-00	
DRAWN BY	SCALE
ADICE DENIS	1:1
DATE	WEIGHT
21/02/2024	
 Azimuth Machinery Inc. P 450 632 8080 F 450 552 8081 www.azimuthpress.com 6042 Rue 132, Ste-Catherine QC, CANADA, J5C 1B6	
PROPRIETARY AND CONFIDENTIAL THE INFORMATION CONTAINED IN THIS DRAWING IS THE SOLE PROPERTY OF AZIMUTH MACHINERY. ANY REPRODUCTION IN PART OR AS A WHOLE WITHOUT THE WRITTEN PERMISSION OF AZIMUTH MACHINERY IS PROHIBITED.	

2014_Engineering1_Producer4_FooterAS-F1-AZ-F1-200-01_Drawing1

PAGE 1/11



ITEM NO.	PART NUMBER	DESCRIPTION	QTY.
1	AZ-F1-200-4101-00	ROLLER	1
2	5972K245	Ball Bearing	2
3	AZ-F1-200-4103-00	SHAFT	1

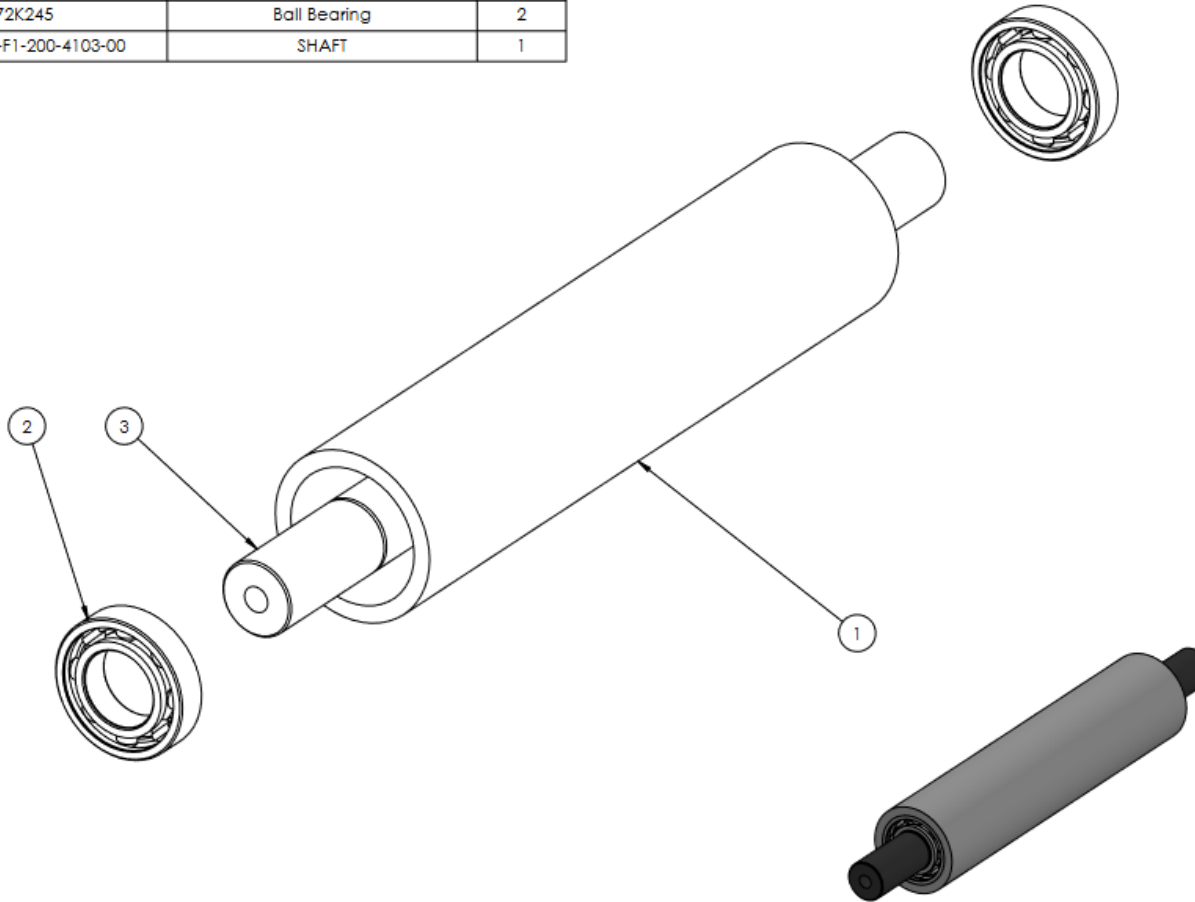

DESCRIPTION	
ROLLER ASSEMBLY	
PART NO.	
AZ-F1-200-4100-00	
DRAWN BY	SCALE
ALICE DENIS	1:1
DATE	WEIGHT
2/15/2024	
	
<small> AZIMUTH MACHINERY (INC.) 7 443 600 4001 7 450 552 5001 www.azimuthpress.com 6040 Rue 132, Ste-Catherine J5C 1B6 QUEBEC, QC H3S 1G6 </small>	
<small> PROPRIETARY AND CONFIDENTIAL THE INFORMATION CONTAINED IN THIS DRAWING IS THE SOLE PROPERTY OF AZIMUTH MACHINERY. ANY REPRODUCTION IN PART OR AS A WHOLE WITHOUT THE WRITTEN PERMISSION OF AZIMUTH MACHINERY IS PROHIBITED. </small>	

X:\4_Engineering\1_Products\Factor4\Factor4\FAB\F1\AZ-F1-2001_Drawing

PAGE 1/1



ITEM NO.	PART NUMBER	DESCRIPTION	QTY.
1	AZ-F1-200-5001-00	BODY	1
2	AZ-F1-200-5002-00	CYLINDER	1
3	AZ-F1-200-5003-00	TOP/BOTTOM	2
4	AZ-F1-200-5004-00	ZINC ADJUSTABLE-POSITION HANDLE	1
5	AZ-F1-200-5005-00	FULLY THREADED T-SLOT NUT	1
6	AZ-F1-200-5006-00	BALL BEARING	2
7	B18.3.6M - M12 x 1.75 x 70 Hex Socket Flat Pt. SS --N		1

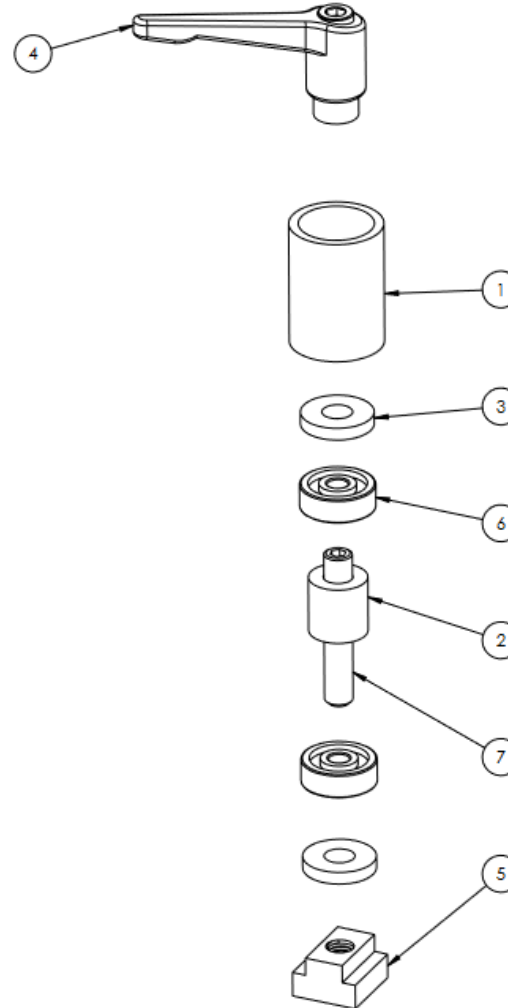
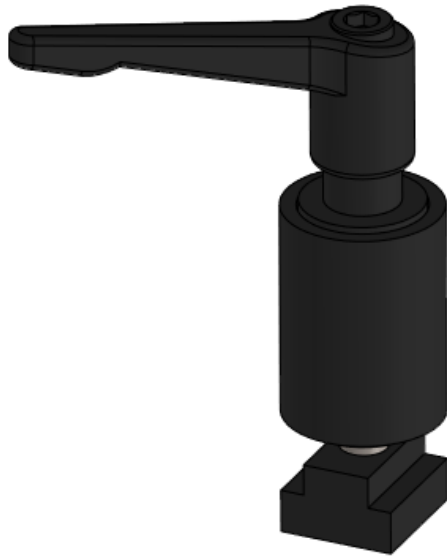

DESCRIPTION	
WIDTH LIMITER	
PART NO	
AZ-F1-200-5000-00	
DRAWN BY	SCALE
ALICE DENIS	1:1.75
DATE	WEIGHT
27/03/2024	
 Azimuth Machinery Inc. 1445001000 1450 632 8080 www.azimuthpress.com 6040 Rue 132, Ste-Catherine QC J5C 1B6	
PROPRIETARY AND CONFIDENTIAL THE INFORMATION CONTAINED IN THIS DRAWING IS THE SOLE PROPERTY OF AZIMUTH MACHINERY. ANY REPRODUCTION IN PART OR AS A WHOLE WITHOUT THE WRITTEN PERMISSION OF AZIMUTH MACHINERY IS PROHIBITED.	



ITEM NO.	PART NUMBER	DESCRIPTION	QTY.
1	AZ-F1-200-6001-00	MOTOR	1
2	AZ-F1-200-6002-00	SMALL TIMING PULLEY	1
3	AZ-F1-200-6003-00	BELT	1

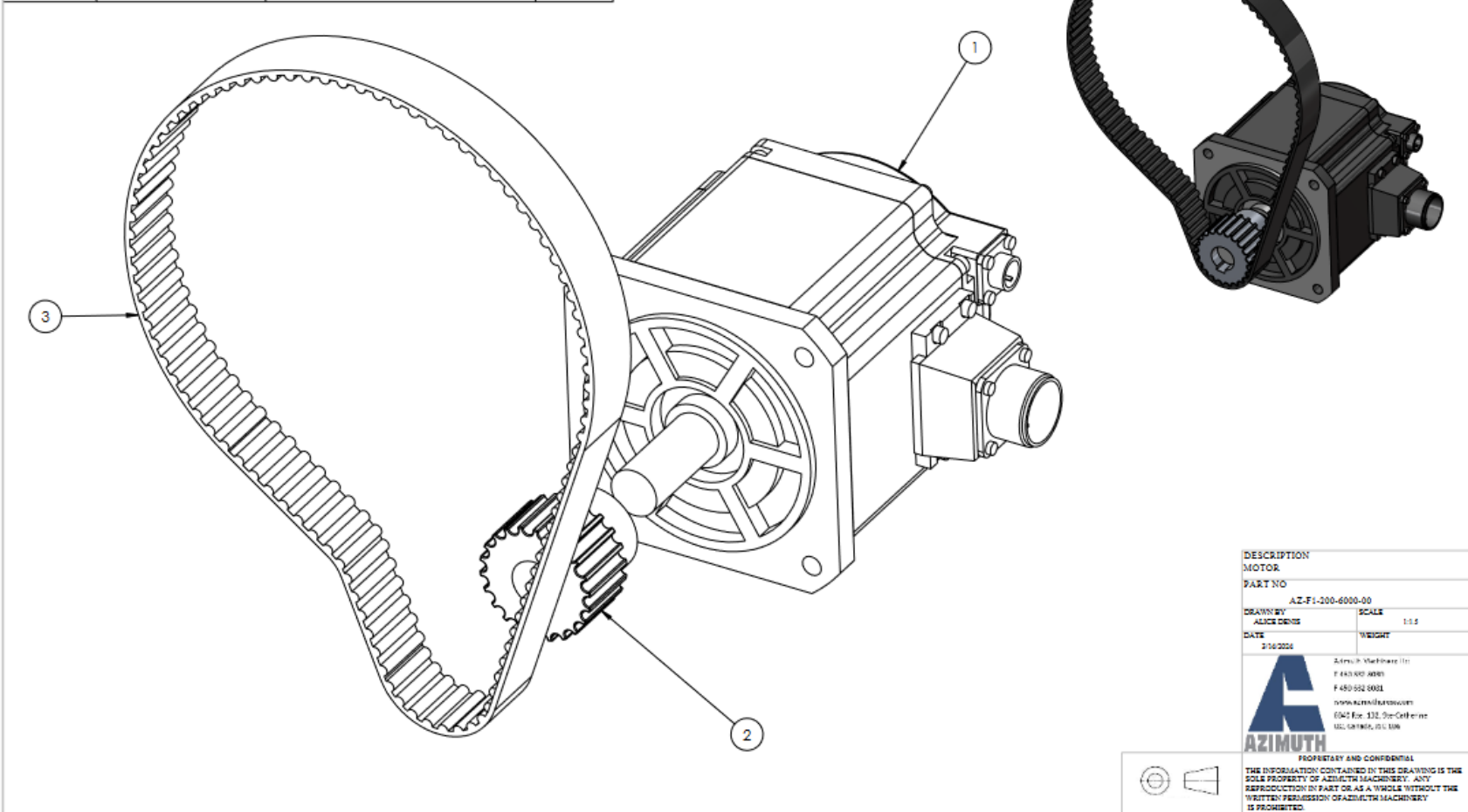

DESCRIPTION	
MOTOR	
PART NO	
AZ-F1-200-6000-00	
DRAWN BY	SCALE
ALICE DENIS	1:1.5
DATE	WEIGHT
2/10/2024	

Azimuth Machinery Inc.
 F 450 632 8080
 F 450 552 5021
www.azimuthpress.com
 6040 Rue 132, Ste-Catherine
 QC, Canada, J5C 1B6



PROPRIETARY AND CONFIDENTIAL
 THE INFORMATION CONTAINED IN THIS DRAWING IS THE
 SOLE PROPERTY OF AZIMUTH MACHINERY. ANY
 REPRODUCTION IN PART OR AS A WHOLE WITHOUT THE
 WRITTEN PERMISSION OF AZIMUTH MACHINERY
 IS PROHIBITED.

2/10/2024, Engineering:1, Product:4, Folder:AZ-F1-AZ-F1-2001, Drawing



ITEM NO.	PART NUMBER	DESCRIPTION	QTY.
1	AZ-F1-200-8001-00	BOLTED PLATE	1
2	AZ-F1-200-8002-00	FEEDER SUPPORT	2
3	AZ-F1-200-8003-00	HEIGHT ADJUSTMENT BLOCK	1
4	B18.3.1M - 8 x 1.25 x 20 Hex SHCS -- 20NHX		2
5	B18.3.1M - 8 x 1.25 x 55 Hex SHCS -- 28NHX		2
6	B18.2.3.5M - Hex bolt M16 x 2.0 x 120 --38N		1
7	B18.2.4.6M - Heavy hex nut, M16 x 2 --D-N		1

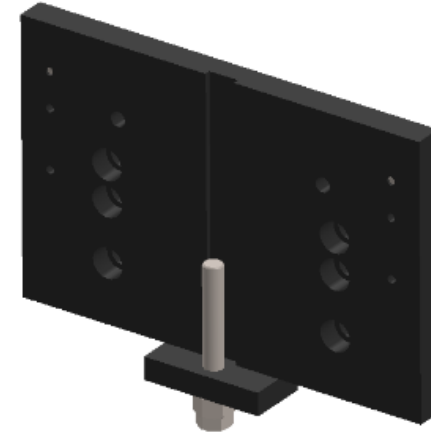
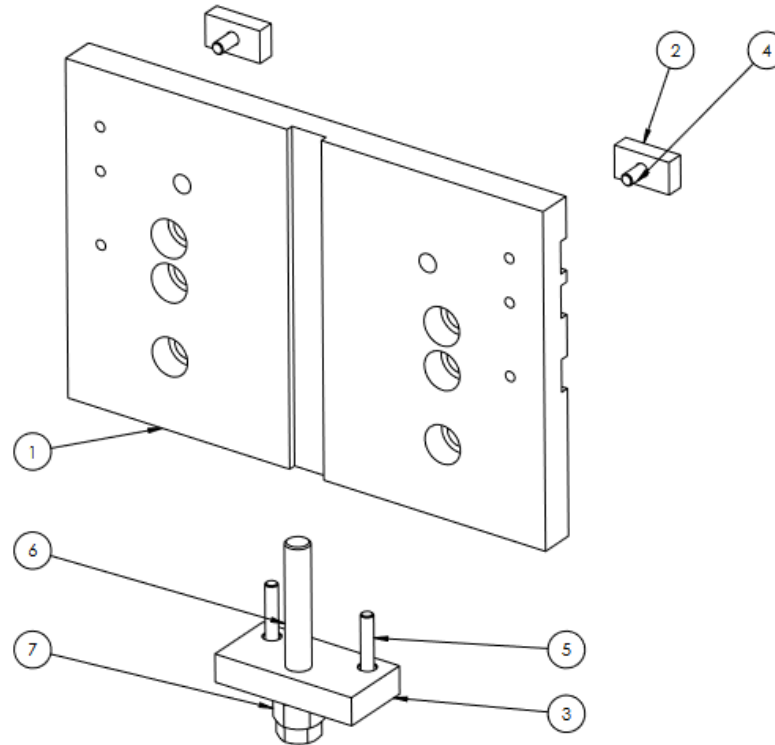

DESCRIPTION	
ADJUSTING PLATE	
PART NO	
AZ-F1-200-8000-00	
DRAWN BY	SCALE
ALICE DENIS	1:25
DATE	WEIGHT
2/10/2024	





Azimuth Machinery Inc.
 7 450 632 8080
 F 450 502 8082
www.azimuthpress.com
 6040 Rue 132, Ste-Catherine
 QC, CANADA, J5C 1B6

PROPRIETARY AND CONFIDENTIAL
 THE INFORMATION CONTAINED IN THIS DRAWING IS THE
 SOLE PROPERTY OF AZIMUTH MACHINERY. ANY
 REPRODUCTION IN PART OR AS A WHOLE WITHOUT THE
 WRITTEN PERMISSION OF AZIMUTH MACHINERY
 IS PROHIBITED.

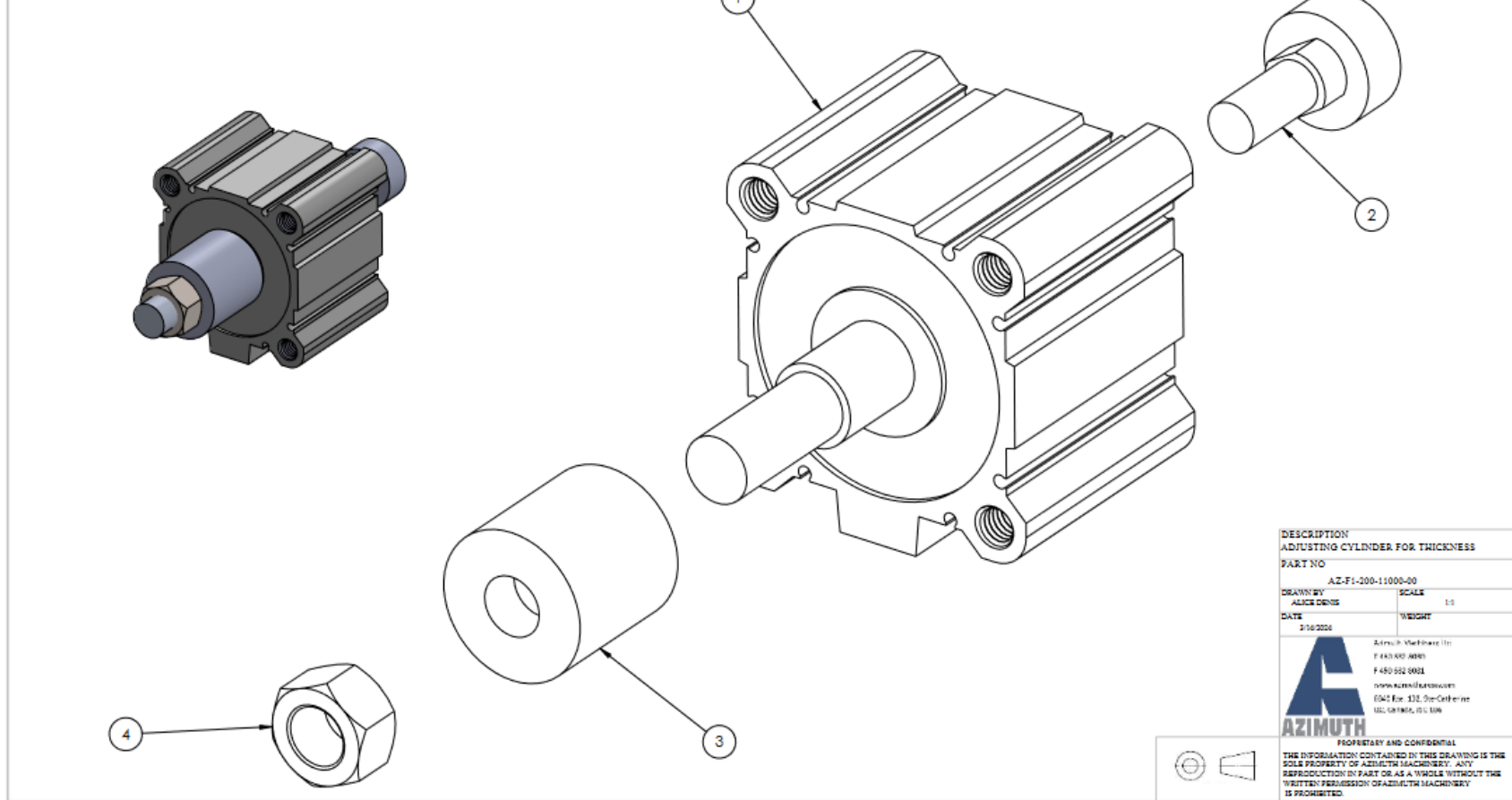

ITEM NO.	PART NUMBER	DESCRIPTION	QTY.
1	AZ-F1-200-11001-00	PNEUMATIC CYLINDER	1
2	AZ-F1-200-11002-00	PISTON	1
3	AZ-F1-200-11003-00	CYLINDER	1
4	HNUT 0.7500-16-D-N		1



DESCRIPTION	
ADJUSTING CYLINDER FOR THICKNESS	
PART NO	
AZ-F1-200-11000-00	
DRAWN BY	SCALE
ALICE DENIS	1:1
DATE	WEIGHT
2/16/2024	
 Azimuth Machinery Inc. F 450 632 8080 F 450 592 4001 www.azimuthpress.com 6040 Rue 132, Ste-Catherine QJ5C 1B6, QJ5C 1B6	
PROPRIETARY AND CONFIDENTIAL THE INFORMATION CONTAINED IN THIS DRAWING IS THE SOLE PROPERTY OF AZIMUTH MACHINERY. ANY REPRODUCTION IN PART OR AS A WHOLE WITHOUT THE WRITTEN PERMISSION OF AZIMUTH MACHINERY IS PROHIBITED.	

2014_Engineering1_Producer4_Footer-AZ-F1-AZ-F1-2001_Drawing

PAGE 1/1



AZ-F1-XXX DIMENSIONS:

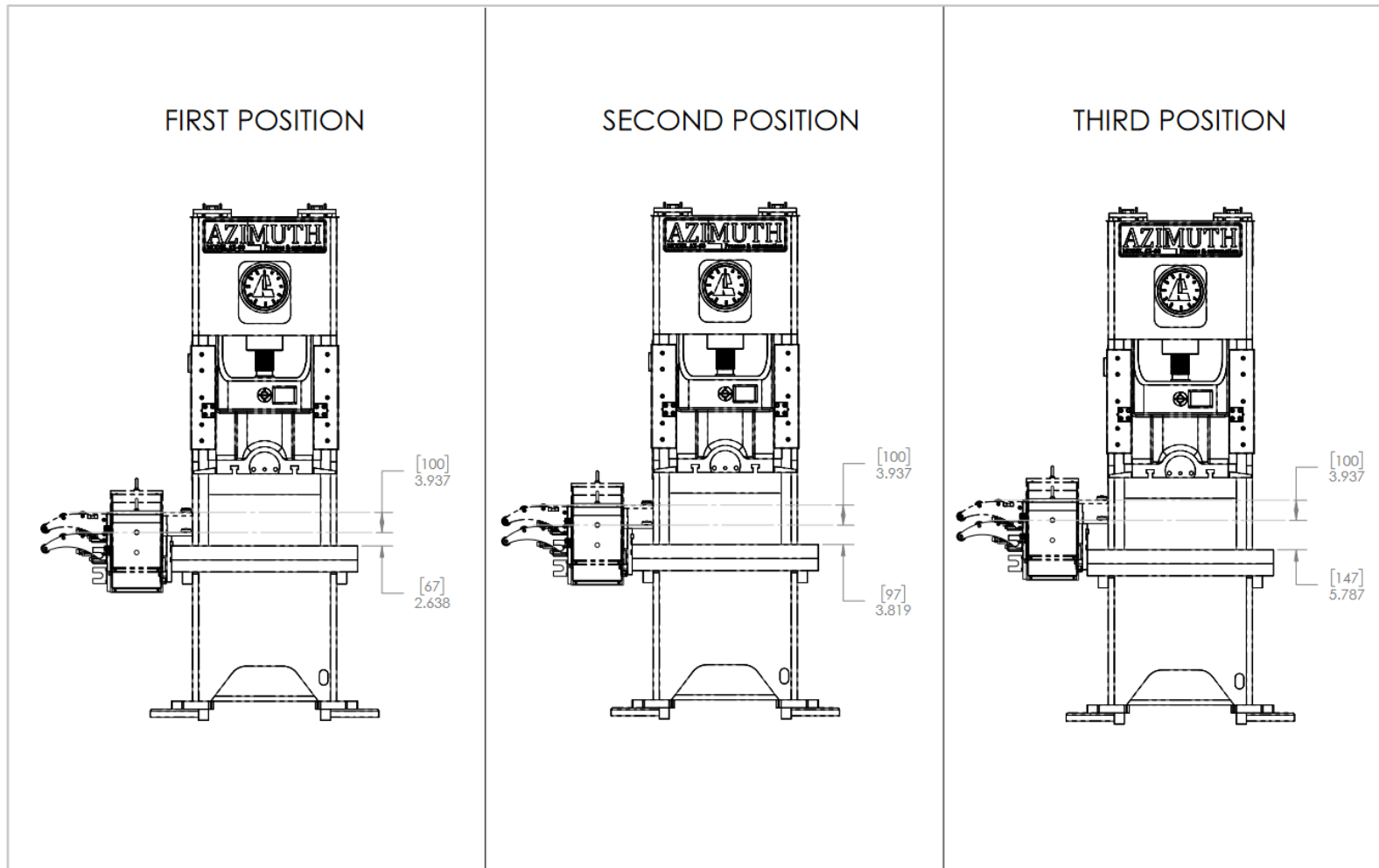

X:\A_Engineering\1_Produit\4_Fonderie\AZ-F1\AZ-F1-4002_Drawing

PAGE 1/4

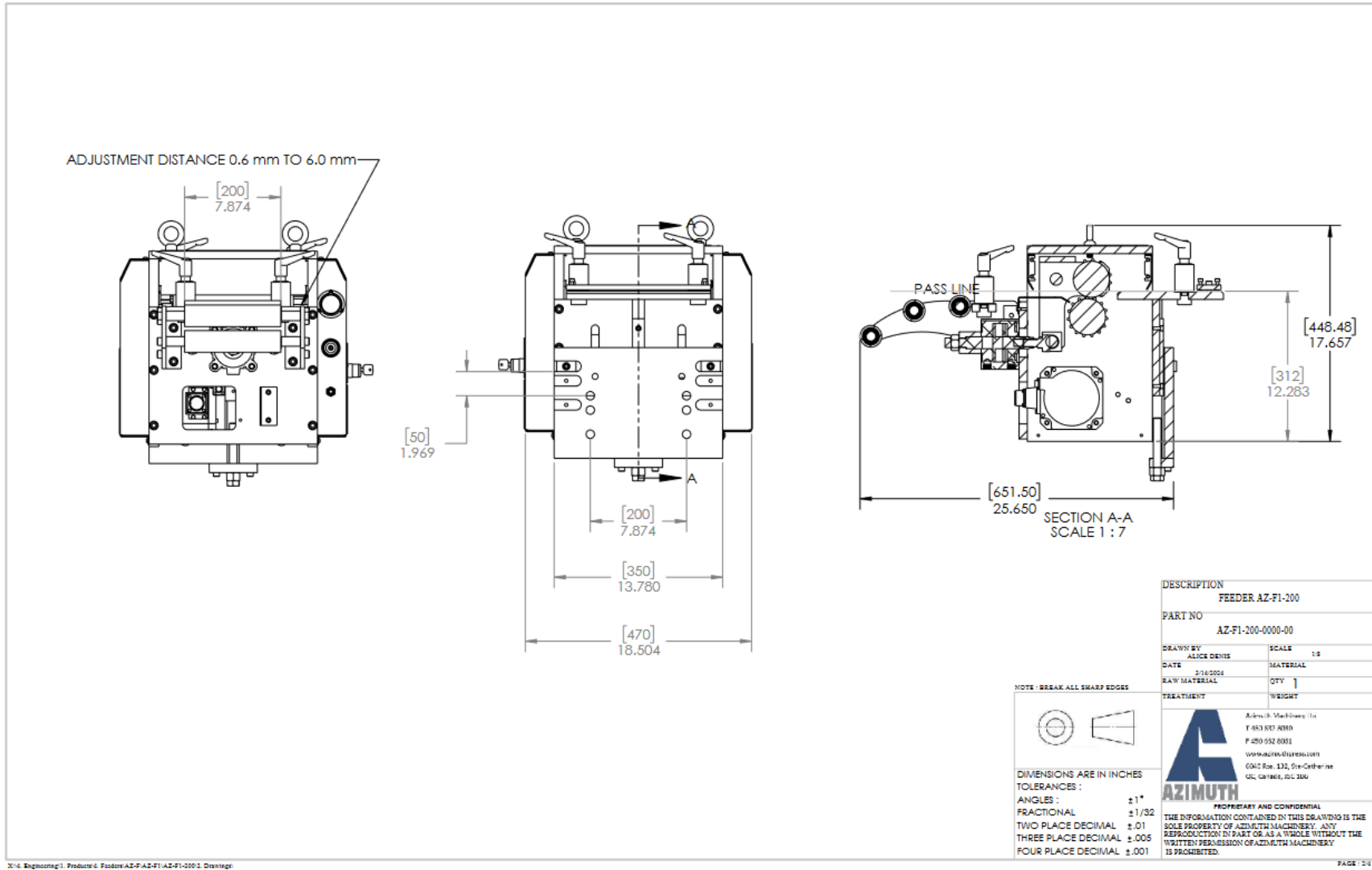

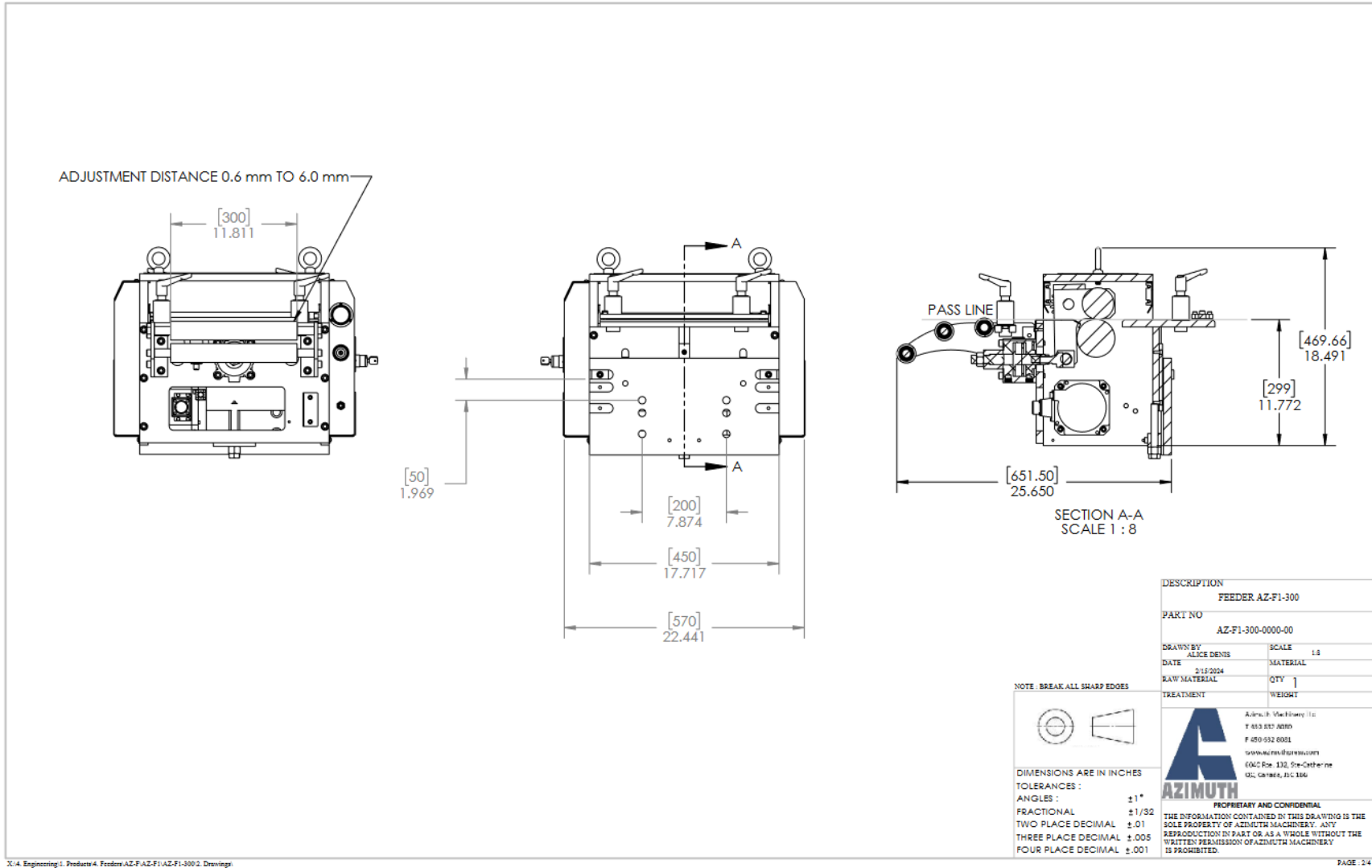

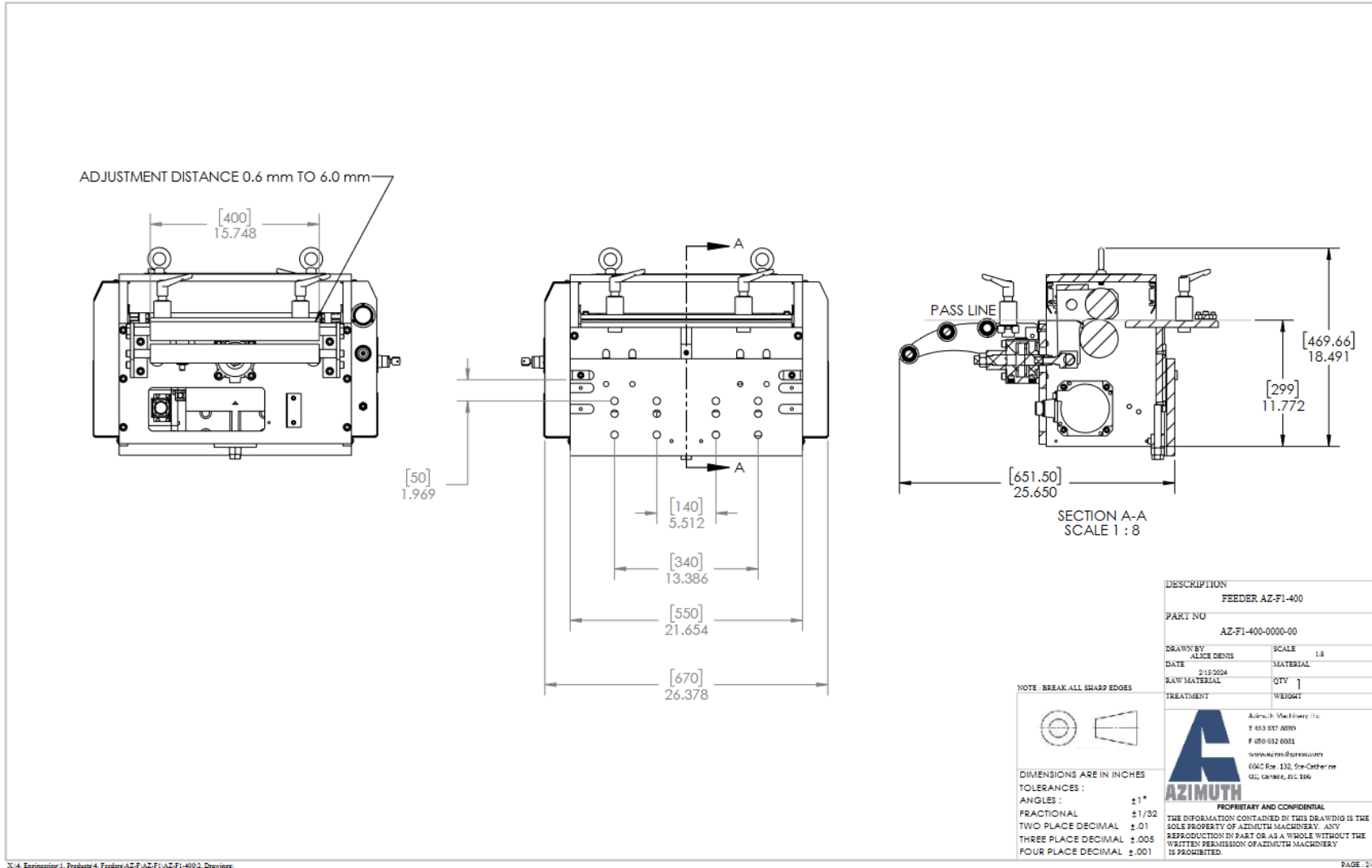

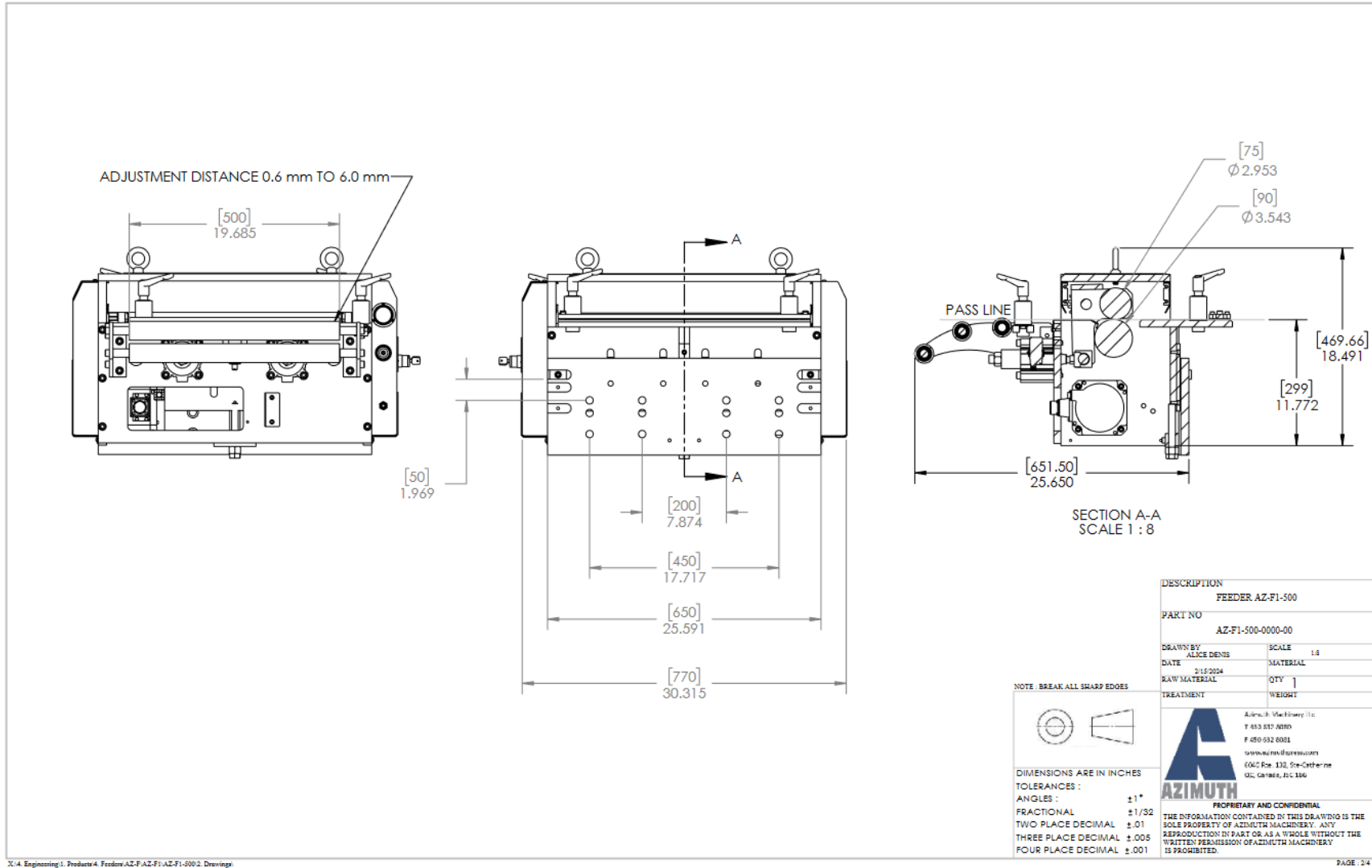

X:\4_Engineering\1_Products\4_Feeder\AZ-F1\AZ-F1-500\2_Drawings

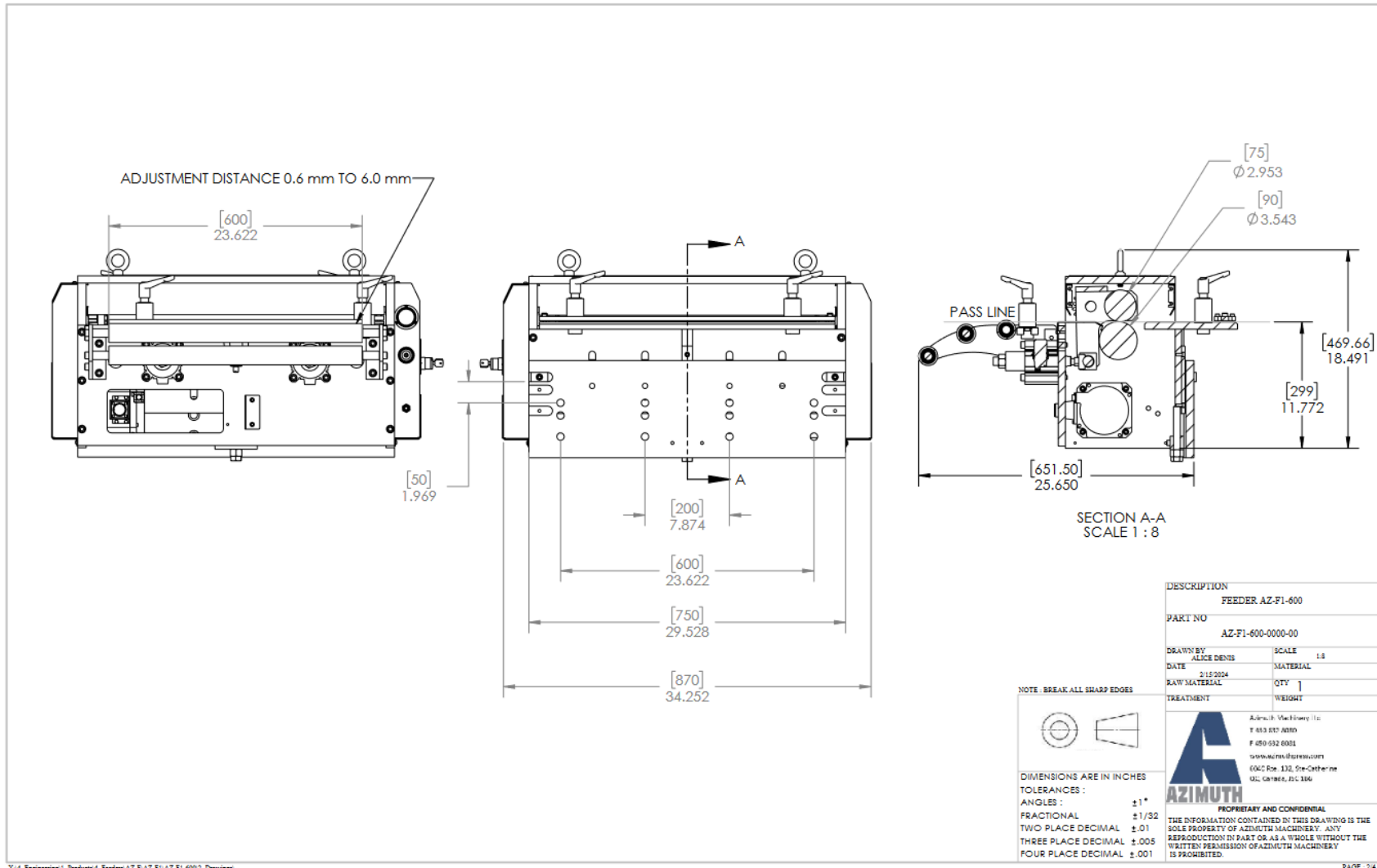



AZ-F2-XXX

AZ-F2-XXX SPARE PARTS:

ITEM NO.	PART NUMBER	DESCRIPTION	QTY.
1	AZ-F2-200-1000-00	FRAME	1
2	AZ-F2-200-2000-00	CRANKSHAFT ASSEMBLY	1
3	AZ-F2-200-3000-00	COUPLING SHAFT	1
4	AZ-F2-200-3100-00	SMALL GEAR ASSEMBLY	1
5	AZ-F2-200-4000-00	ROLLER ASSEMBLY	1
6	AZ-F2-200-5000-00	WIDTH LIMITER	4
7	AZ-F2-200-6000-00	MOTOR	1
8	AZ-F2-200-7000-00	TENSIONER	1
9	AZ-F2-200-8000-00	ADJUSTING PLATE	1
10	AZ-F2-200-9000-00	SENSOR	1
11	AZ-F2-200-11004-00	AIR DIRECTIONAL CONTROL VALVE	1
12	AZ-F2-200-11005-00	SINGLE SCALE PRESSURE GAUGE WITH STEEL CASE	1
13	AZ-F2-200-11006-00	PRESSURE REGULATING VALVE	1
14	AZ-F2-200-11007-00	AIR CONNECTOR	1
15	AZ-F2-200-11008-00	KEY SWITCH 2 POSITIONS	1
16	AZ-F2-200-12001-00	SPECIFICATIONS PLATE	1
17	AZ-F2-200-12002-00	TOP DECO PLATE	1
18	AZ-F2-200-12003-00	FEEDER SIDE DECO PLATE	1
19	AZ-F2-200-12004-00	PILOT RELEASE PLATE	1
24	AZ-F2-200-11000-00	ADJUSTING CYLINDER FOR THICKNESS	1

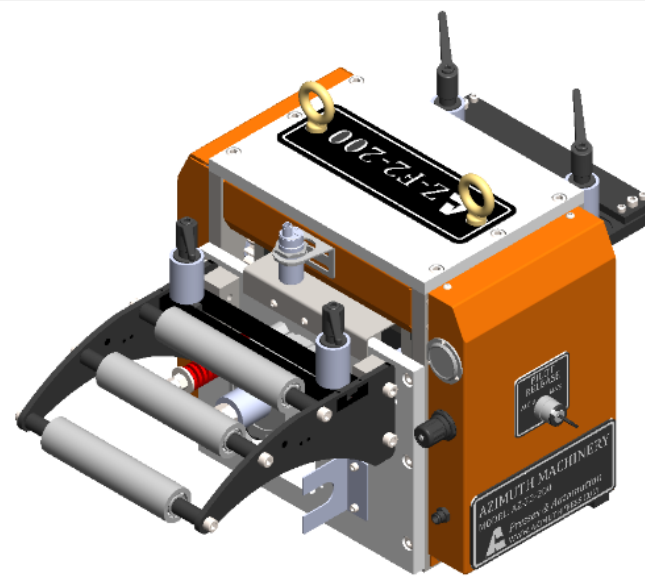

DESCRIPTION	FEEDER AZ-F2-600
PART NO	AZ-F2-600-0000-00
DRAWN BY	ALICE DENIS
DATE	21/02/24
RAW MATERIAL	
TREATMENT	
SCALE	1:1
MATERIAL	
QTY	
WEIGHT	

NOTE: BREAK ALL SHARP EDGES



DIMENSIONS ARE IN INCHES
 TOLERANCES:
 ANGLES: ±1°
 FRACTIONAL: ±1/32
 TWO PLACE DECIMAL: ±.01
 THREE PLACE DECIMAL: ±.003
 FOUR PLACE DECIMAL: ±.001

 Azimuth Machinery Inc.
 6040 Route 132, Ste-Catherine
 Quebec, Canada J5C 1B6
 TEL: 450 632 8080
 FAX: 450 632 8081
 WWW.AZIMUTHPRESS.COM

PROPRIETARY AND CONFIDENTIAL
 THE INFORMATION CONTAINED IN THIS DRAWING IS THE
 SOLE PROPERTY OF AZIMUTH MACHINERY. ANY
 REPRODUCTION IN PART OR AS A WHOLE WITHOUT THE
 WRITTEN PERMISSION OF AZIMUTH MACHINERY
 IS PROHIBITED.

PAGE 04

30/4 Engineering/1_Produit/4_Produit/AZ-F2-AZ-F2-0001_Drawing

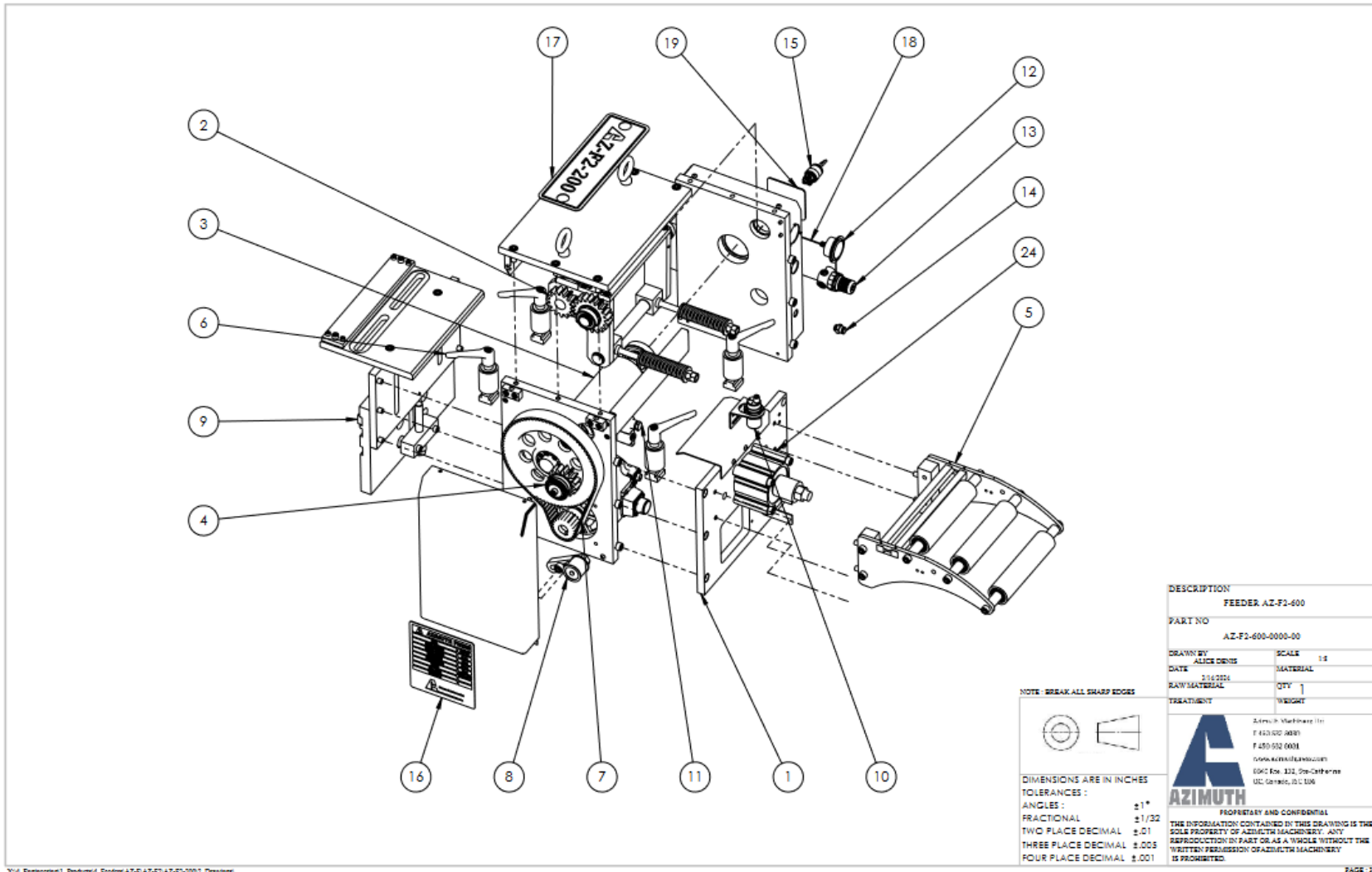

DESCRIPTION	
FEEDER AZ-F1-600	
PART NO	
AZ-F1-600-0000-00	
DRAWN BY	SCALE
ALICE DENIS	1:1
DATE	MATERIAL
2/16/2024	
RAW MATERIAL	QTY
	1
TREATMENT	WEIGHT

	Azimuth Machinery Inc.
	F 450 632 8080
	F 450 532 0001
	www.azimuthpress.com
6040 Rue 132, Ste-Catherine QC G5R 1C1, CANADA	

DIMENSIONS ARE IN INCHES TOLERANCES : ANGLES : ±1° FRACTIONAL ±1/32 TWO PLACE DECIMAL ±.01 THREE PLACE DECIMAL ±.005 FOUR PLACE DECIMAL ±.001	
---	--

PROPERTY AND CONFIDENTIAL THE INFORMATION CONTAINED IN THIS DRAWING IS THE SOLE PROPERTY OF AZIMUTH MACHINERY. ANY REPRODUCTION IN PART OR AS A WHOLE WITHOUT THE WRITTEN PERMISSION OF AZIMUTH MACHINERY IS PROHIBITED.	
---	--

2024 Engineering 1, Product 4, Feeder AZ-F1-AZ-F1-AZ-F1-0001, Drawing

ITEM NO.	PART NUMBER	DESCRIPTION	QTY.
1	AZ-F2-200-1001-00	BACK PLATE	1
2	AZ-F2-200-1002-00	TOP PLATE	1
3	AZ-F2-200-1003-00	RIGHT SIDE PLATE	1
4	AZ-F2-200-1004-00	LEFT SIDE PLATE	1
5	AZ-F2-200-1005-00	ADJUSTING FRONT PLATE	1
6	AZ-F2-200-1006-00	MATERIAL TABLE	1
7	AZ-F2-200-1007-00	COVER SUPPORT	4
8	AZ-F2-200-1008-00	SLIDE	1
9	AZ-F2-200-1009-00	CLAMPING PLATE	1
10	AZ-F2-200-1010-00	STEEL EYEBOLT- FOR LIFTING	2
11	AZ-F2-200-10001-00	COVER	1
12	AZ-F2-200-10001-00	COVER	1
13	AZ-F2-200-10002-00	LIMITING SUPPORT	2
14	AZ-F2-200-10003-00	GUIDING PLATE	1
15	AZ-F2-200-10004-00	L PLATE	1
16	B18.3.1M - 8 x 1.25 x 20 Hex SHCS -- 20NHX		2
17	B18.3.1M - 6 x 1.0 x 20 Hex SHCS -- 20NHX		20
18	B18.3.1M - 10 x 1.5 x 25 Hex SHCS -- 25NHX		10
19	B18.3.1M - 10 x 1.5 x 16 Hex SHCS -- 16NHX		8
20	B18.3.1M - 10 x 1.5 x 20 Hex SHCS -- 20NHX		2
21	B18.3.1M - 6 x 1.0 x 16 Hex SHCS -- 16NHX		2
22	B18.3.1M - 6 x 1.0 x 12 Hex SHCS -- 12NHX		2
23	B18.3.4M - 6 x 1.0 x 10 SBHCS --N		8
24	B18.3.4M - 6 x 1.0 x 6 SBHCS --N		3

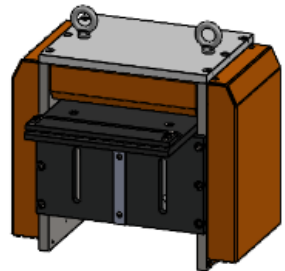
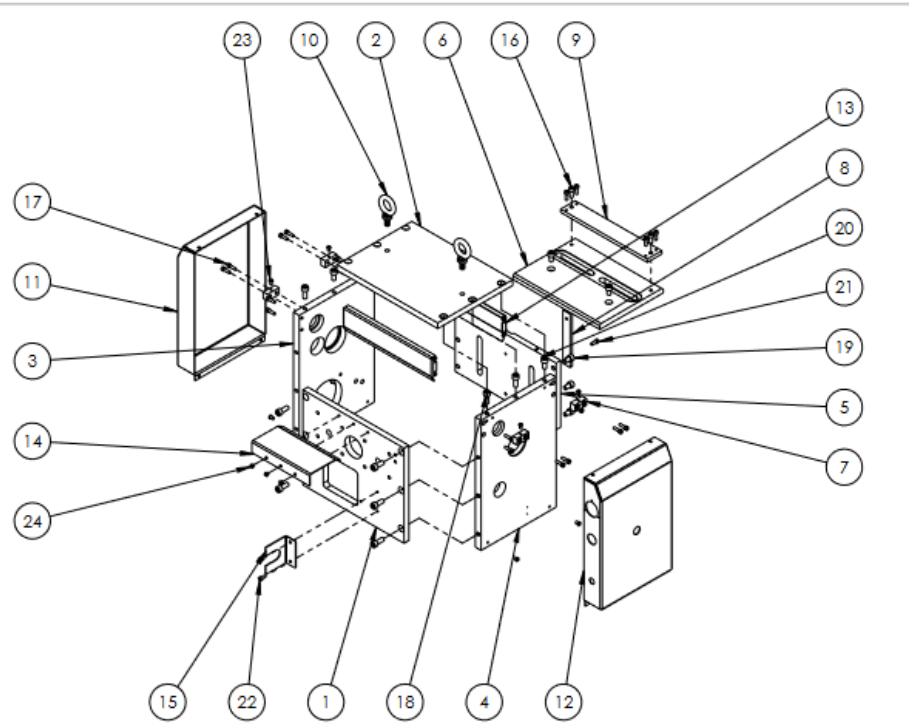



DESCRIPTION	FRAME
PART NO	AZ-F2-200-1000-00
DRAWING	SCALE 1:10
DATE	2/16/2024
 Azimuth Machinery Inc. T 450 632 8080 F 450 632 8081 www.azimuthpress.com 6040 Rue 132, Ste-Catherine QC, Canada, J5C 1B6	
PROPERTY AND CONFIDENTIAL THE INFORMATION CONTAINED IN THIS DRAWING IS THE SOLE PROPERTY OF AZIMUTH MACHINERY. ANY REPRODUCTION IN PART OR AS A WHOLE WITHOUT THE WRITTEN PERMISSION OF AZIMUTH MACHINERY IS PROHIBITED.	

X:\4_Engineering\1_Products\Framing\AZ-F2-AZ-F2-2001_Drawing

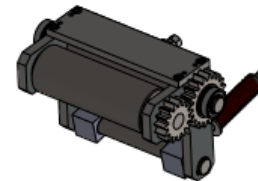
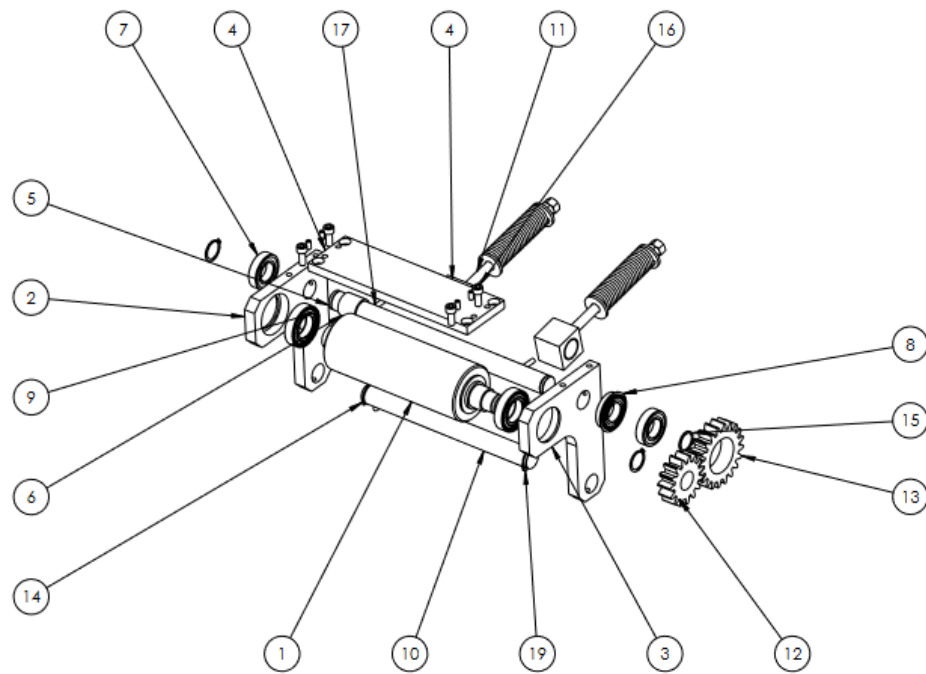

ITEM NO.	PART NUMBER	DESCRIPTION	QTY.
1	AZ-F2-200-2001-00	ROLLER	1
2	AZ-F2-200-2002-00	RIGHT SUPPORT	1
3	AZ-F2-200-2003-00	LEFT SUPPORT	1
4	AZ-F2-200-2004-00	TOP	1
5	AZ-F2-200-2005-00	SHAFT GEAR </td <td>1</td>	1
6	AZ-F2-200-2006-00	BUSHING	1
7	AZ-F2-200-2007-00	PERMANENTLY LUBRICATED BALL BEARING	2
8	AZ-F2-200-2008-00	SINGLE ROW DEEP GROOVE BEARING WITH A SNAP RING	1
9	AZ-F2-200-2009-00	BALL BEARING	2
10	AZ-F2-200-2010-00	SPRING SHAFT	1
11	AZ-F2-200-2100-00	SPRING	2
12	AZ-F2-200-2011-00	SPUR GEAR	1
13	AZ-F2-200-2012-00	SPUR GEAR	1
14	B27.7M - 3AM1-25		4
15	B27.7M - 3AM1-24		1
16	B18.3.1M - 8 x 1.25 x 20 Hex SHCS -- 20NHX		4
17	B18.3.6M - M6 x 1.0 x 20 Hex Socket Flat Pt. SS --N		2
18	B18.3.6M - M6 x 1.0 x 12 Hex Socket Flat Pt. SS --N		4
19	B18.3.6M - M6 x 1.0 x 8 Hex Socket Flat Pt. SS -N		2





DESCRIPTION	
CRANKSHAFT ASSEMBLY	
PART NO	
AZ-F2-600-2000-00	
DRAWN BY	SCALE
JALICE DENIS	1:1
DATE	WEIGHT
2/16/2024	
 Azimuth Machinery Inc. P 450 632 8080 F 450 552 0051 www.azimuthpress.com 6042 Rue 132, Ste-Catherine QC J5C 1B6, Q1 1B6	
PROPRIETARY AND CONFIDENTIAL THE INFORMATION CONTAINED IN THIS DRAWING IS THE SOLE PROPERTY OF AZIMUTH MACHINERY. ANY REPRODUCTION IN PART OR AS A WHOLE WITHOUT THE WRITTEN PERMISSION OF AZIMUTH MACHINERY IS PROHIBITED.	

2014 Engineering 1, Product 4, Folder AZ-F2-AZ-F2-2001, Drawing

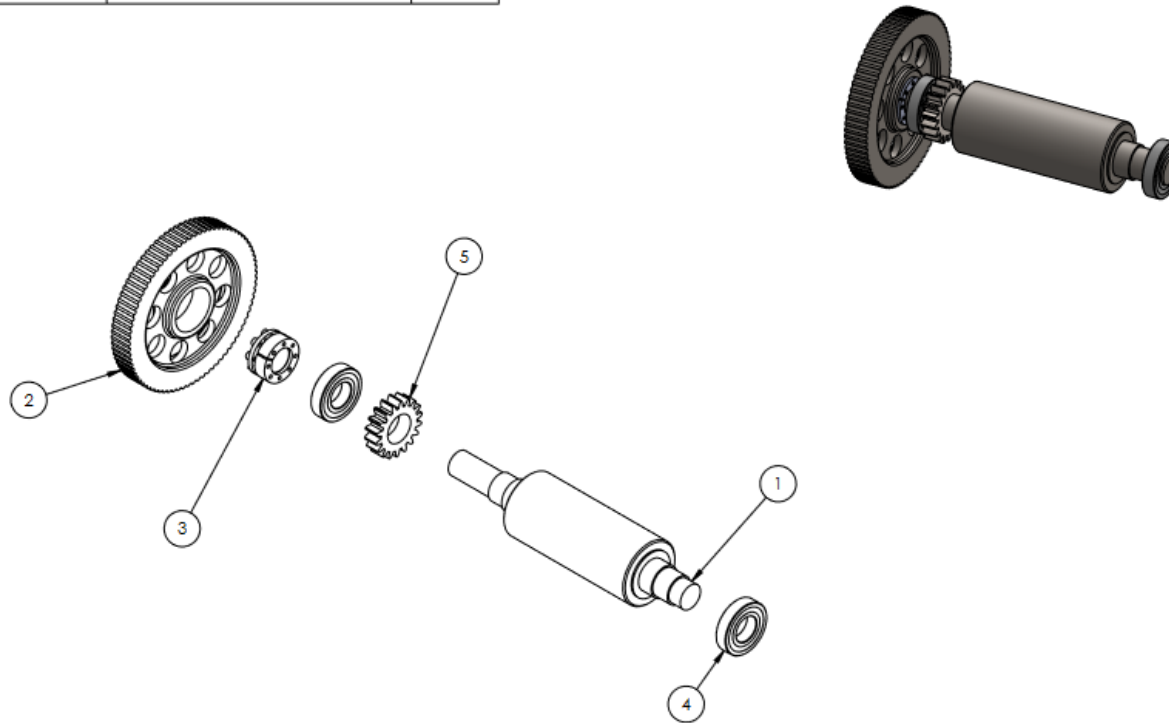

ITEM NO.	PART NUMBER	DESCRIPTION	QTY.
1	AZ-F2-200-3001-00	ROLLER	1
2	AZ-F2-200-3002-00	SPROCKET	1
3	AZ-F2-200-3003-00	LOCK	1
4	AZ-F2-200-3004-00	PERMANENTLY LUBRICATED BALL BEARING	2
5	AZ-F2-200-3005-00	SPUR GEAR	1



DESCRIPTION	
COUPLING SHAFT	
PART NO	
AZ-F2-600-3000-00	
DRAWN BY	SCALE
ALICE DENIS	1:1
DATE	WEIGHT
2/16/2024	
 Azimuth Machinery Ltd 2 443 900 4881 2 480 662 8082 www.azimuthpress.com 6040 Rue 132, Ste-Catherine QC, Canada, J5C 1B6	
PROPRIETARY AND CONFIDENTIAL THE INFORMATION CONTAINED IN THIS DRAWING IS THE SOLE PROPERTY OF AZIMUTH MACHINERY. ANY REPRODUCTION IN PART OR AS A WHOLE WITHOUT THE WRITTEN PERMISSION OF AZIMUTH MACHINERY IS PROHIBITED.	

2016, Engineering 1, Product 4, Folder AZ-F2-AZ-F2-3000, Drawing

PAGE 1/1



ITEM NO.	PART NUMBER	DESCRIPTION	QTY.
1	AZ-F2-400-3101-00	SMALL SHAFT	1
2	AZ-F2-400-2008-00	SINGLE ROW DEEP GROOVE BEARING WITH A SNAP RING	2
3	AZ-F2-200-3102-00	SPUR GEAR	1
4	B18.3.1M - 8 x 1.25 x 20 Hex SHCS – 20NHX		1
5	B18.22M - Plain washer, 8 mm, wide		1

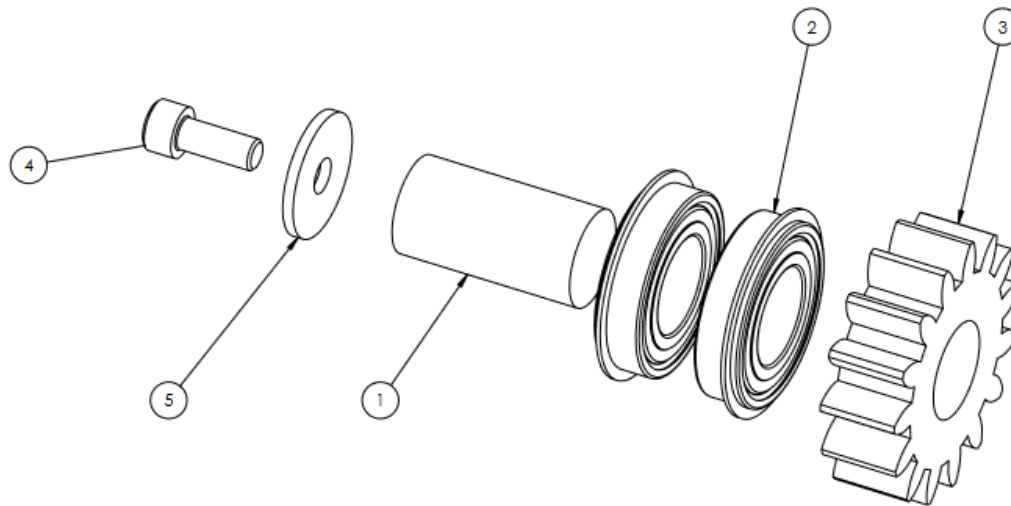
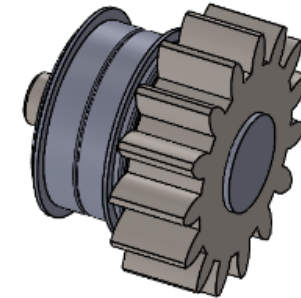

DESCRIPTION	
SMALL GEAR ASSEMBLY	
PART NO	
DRAWN BY	SCALE
ALICE DENIS	1:1
DATE	WEIGHT
2/24/2024	
	
Azimuth Machinery Inc. 7 450 632 8080 F 450 552 9021 www.azimuthpress.com 6040 Rue 132, Ste-Catherine QC, J5C 1B6, CANADA	
PROPRIETARY AND CONFIDENTIAL THE INFORMATION CONTAINED IN THIS DRAWING IS THE SOLE PROPERTY OF AZIMUTH MACHINERY. ANY REPRODUCTION IN PART OR AS A WHOLE WITHOUT THE WRITTEN PERMISSION OF AZIMUTH MACHINERY IS PROHIBITED.	

X:\4_Engineering\1_Products\4_Foodora\AZ-F2-AZ-F2-2002_Drawing

PAGE 1/1



ITEM NO.	PART NUMBER	DESCRIPTION	QTY.
1	AZ-F2-200-4001-00	SIDE SUPPORT	2
2	AZ-F2-200-4002-00	ATTACH BLOCK	2
3	AZ-F2-200-4003-00	DISTANCE SUPPORT	2
4	AZ-F2-200-4100-00	ROLLER ASSEMBLY	3
5	B18.3.1M - 10 x 1.5 x 25 Hex SHCS -- 25NHX		6
6	B18.3.1M - 10 x 1.5 x 30 Hex SHCS -- 30NHX		2
7	B18.3.1M - 10 x 1.5 x 16 Hex SHCS -- 16NHX		2
8	B18.3.1M - 10 x 1.5 x 40 Hex SHCS -- 40NHX		4

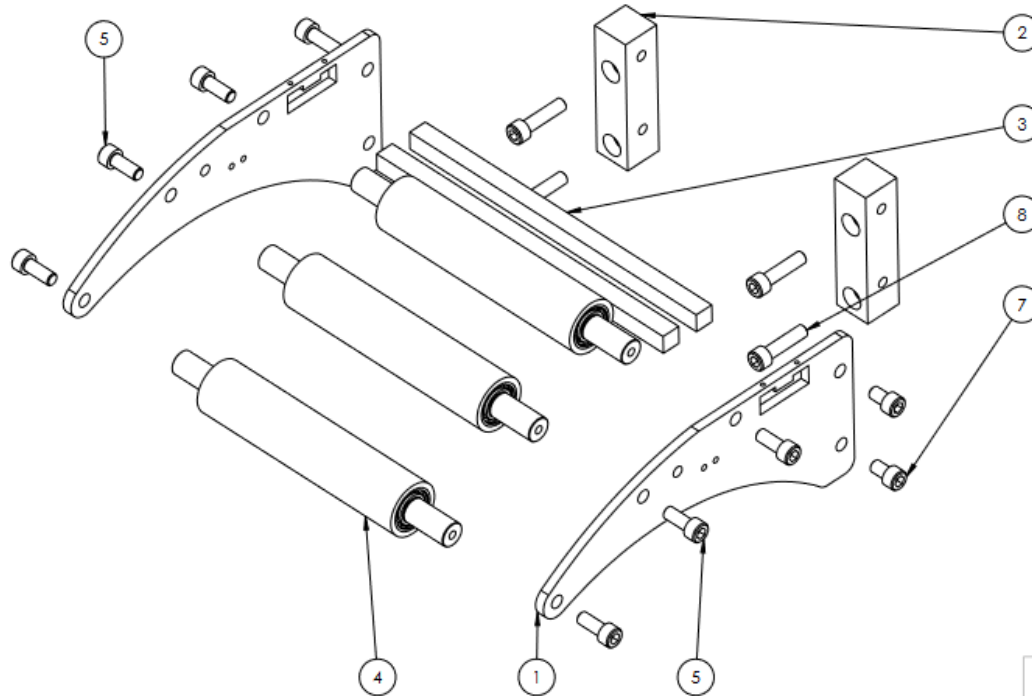

DESCRIPTION	
ROLLER ASSEMBLY	
PART NO	
AZ-F2-600-4000-00	
DRAWN BY	SCALE
ALICE DENIS	1:0
DATE	WEIGHT
23/02/2024	
Address: 6040 Route 132 F 450 632 8080 F 450 632 8081 www.azimuthpress.com 6040 Ex. 132, Ste-Catherine QC J5C 1B6, CANADA	
	
PROPRIETARY AND CONFIDENTIAL THE INFORMATION CONTAINED IN THIS DRAWING IS THE SOLE PROPERTY OF AZIMUTH MACHINERY. ANY REPRODUCTION IN PART OR AS A WHOLE WITHOUT THE WRITTEN PERMISSION OF AZIMUTH MACHINERY IS PROHIBITED.	

2024 Engineering1, Product 4, Product AZ-F2-AZ-F2-200, Drawing

PAGE 1/1



ITEM NO.	PART NUMBER	DESCRIPTION	QTY.
1	AZ-F2-200-5001-00	BODY	1
2	AZ-F2-200-5002-00	CYLINDER	1
3	AZ-F2-200-5003-00	TOP/BOTTOM	2
4	AZ-F2-200-5004-00	ZINC ADJUSTABLE-POSITION HANDLE	1
5	AZ-F2-200-5005-00	FULLY THREADED T-SLOT NUT	1
6	AZ-F2-200-5006-00	BALL BEARING	2
7	B18.3.6M - M12 x 1.75 x 70 Hex Socket Flat Pt. SS --N		1

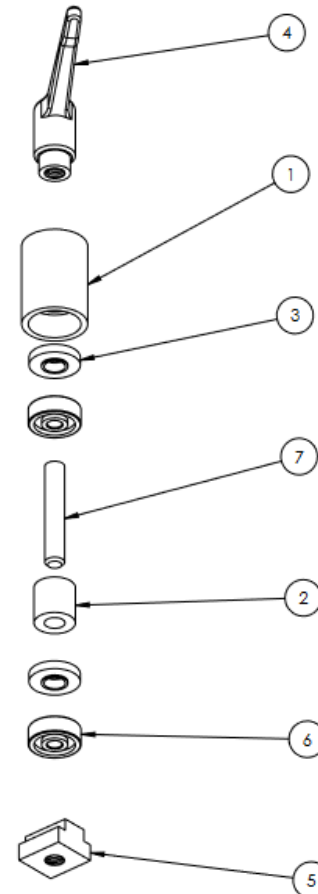

DESCRIPTION	
WIDTH LIMITER	
PART NO	
AZ-F2-600-5000-00	
DRAWN BY	SCALE
ALICE DENIS	1:1
DATE	WEIGHT
01/02/2024	
 Azimuth Machinery Inc. 4430 Ave 450 632 8081 www.azimuthpress.com 6040 Rte. 132, Ste-Catherine QC, CANADA, J5C 1B6	
PROPRIETARY AND CONFIDENTIAL THE INFORMATION CONTAINED IN THIS DRAWING IS THE SOLE PROPERTY OF AZIMUTH MACHINERY. ANY REPRODUCTION IN PART OR AS A WHOLE WITHOUT THE WRITTEN PERMISSION OF AZIMUTH MACHINERY IS PROHIBITED.	

2014 Engineering 1 - Product 4 - Product AZ-F2-AZ-F2-5000 - Drawing

PAGE 1/1



ITEM NO.	PART NUMBER	DESCRIPTION	QTY.
1	AZ-F2-200-6001-00	MOTOR OMRON SLC V1.1	1
2	AZ-F2-200-6002-00	SMALL TIMING PULLEY	1
3	AZ-F2-200-6003-00	BELT	1

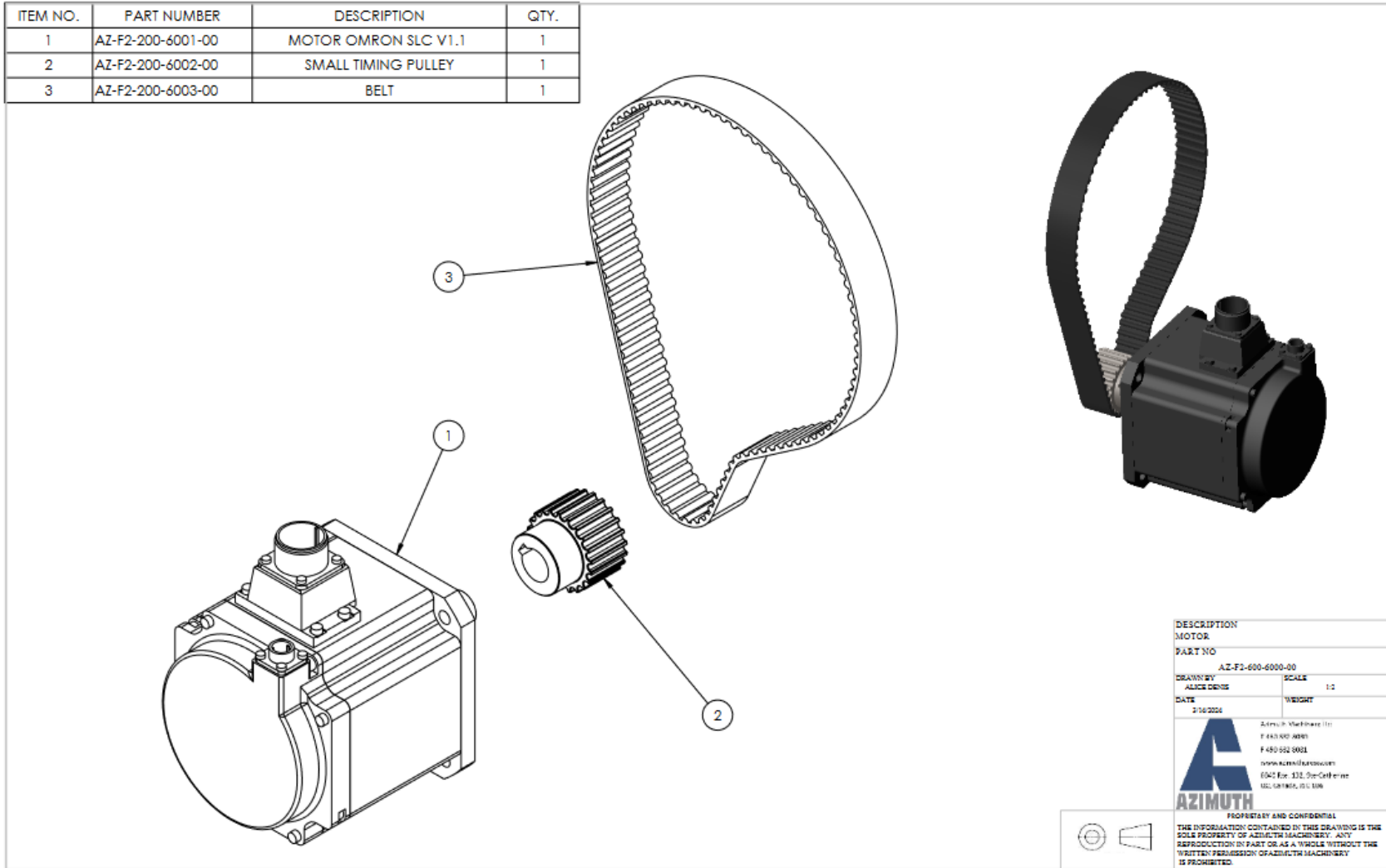

2016_Enginering1_Produit4_Produit4_AZ-F2-AZ-F2-AZ-F2-2002_Drawing

DESCRIPTION	
MOTOR	
PART NO	
AZ-F2-600-6000-00	
DESIGNED BY	SCALE
ALEX DEBIS	1:1
DATE	WEIGHT
21/02/2016	
 Azimuth Machinery Inc. 4430 RD 4891 F 450 632 8081 www.azimuthpress.com 6040 Ex. 132, Ste-Catherine QUEBEC, Q.C. CAN.	
PROPRIETARY AND CONFIDENTIAL THE INFORMATION CONTAINED IN THIS DRAWING IS THE SOLE PROPERTY OF AZIMUTH MACHINERY. ANY REPRODUCTION IN PART OR AS A WHOLE WITHOUT THE WRITTEN PERMISSION OF AZIMUTH MACHINERY IS PROHIBITED.	

PAGE 1/1



ITEM NO.	PART NUMBER	DESCRIPTION	QTY.
1	AZ-F2-200-8001-00	BOLTED PLATE	1
2	AZ-F2-200-8002-00	FEEDER SUPPORT	2
3	AZ-F2-200-8003-00	HEIGHT ADJUSTMENT BLOCK	1
4	B18.3.1M - 8 x 1.25 x 20 Hex SHCS -- 20NHX		2
5	B18.3.1M - 8 x 1.25 x 55 Hex SHCS -- 28NHX		2
6	B18.2.3.5M - Hex bolt M16 x 2.0 x 120 --38N		1
7	B18.2.4.6M - Heavy hex nut, M16 x 2 --D-N		1

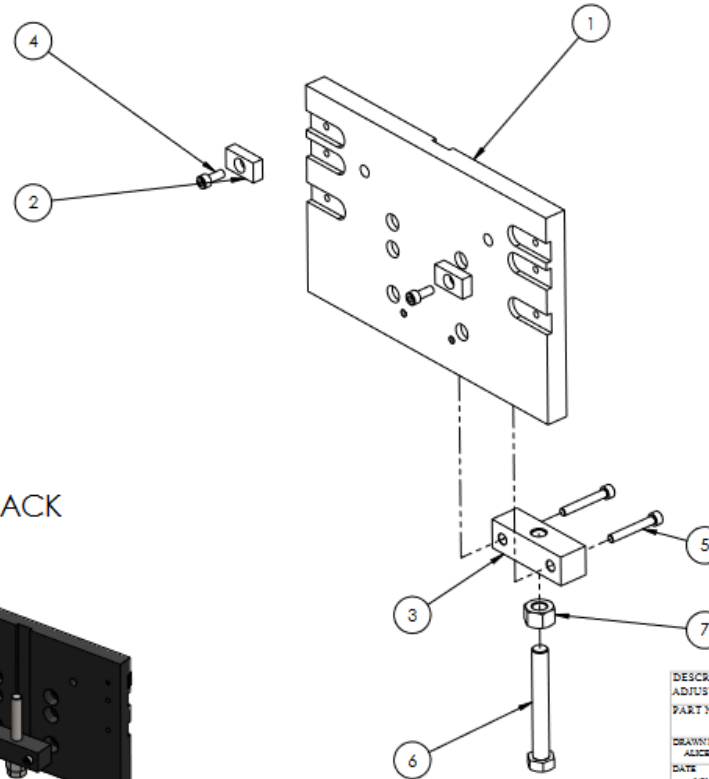

FRONT



BACK

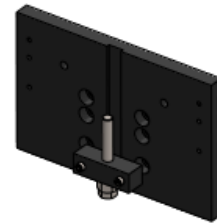

DESCRIPTION	
ADJUSTING PLATE	
PART NO	
AZ-F2-200-8000-00	
DRAWN BY	SCALE
ALICE DENIS	1:1
DATE	WEIGHT
1/21/2024	
	
4500 St-Mathieu (St) F 450 632 8080 F 450 632 0431 www.azimuthpress.com 6040 Ex. 132, Ste-Catherine QC J5C 1B6, CANADA	
PROPRIETARY AND CONFIDENTIAL THE INFORMATION CONTAINED IN THIS DRAWING IS THE SOLE PROPERTY OF AZIMUTH MACHINERY. ANY REPRODUCTION IN PART OR AS A WHOLE WITHOUT THE WRITTEN PERMISSION OF AZIMUTH MACHINERY IS PROHIBITED.	

X:\4_Engineering\1_Productions\Footer\AZ-F2-AZ-F2-2001_Drawing

PAGE 1/1



ITEM NO.	PART NUMBER	DESCRIPTION	QTY.
1	AZ-F2-200-9001-00	SENSOR	1
2	AZ-F2-200-9002-00	SENSOR SUPPORT	1

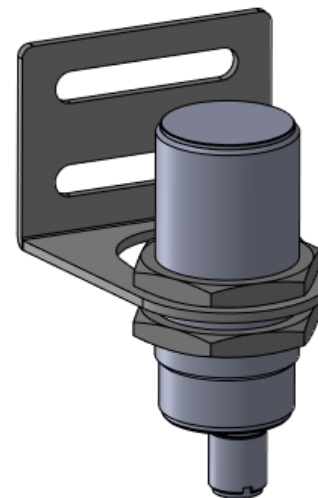
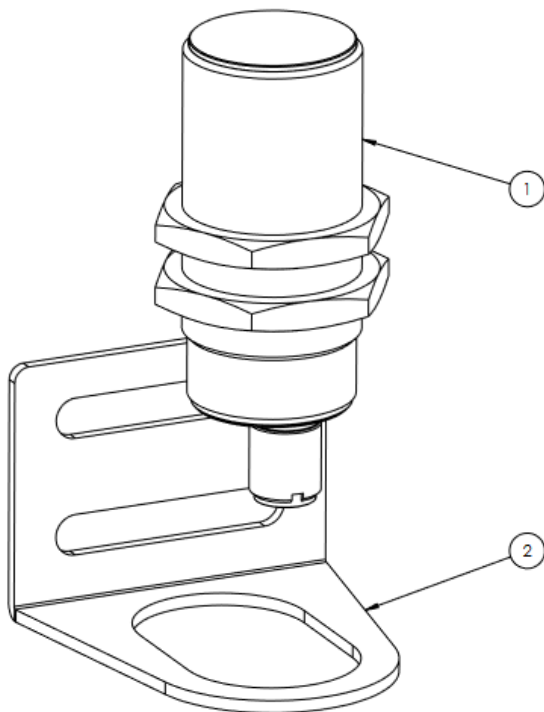

DESCRIPTION	
SENSOR	
PART NO	
AZ-F2-200-9000-00	
DRAWN BY	SCALE
ALICE DENIS	1:1
DATE	WEIGHT
2/16/2024	



Azimuth Machinery (in)
 1400 RUE DE
 1400 RUE DE
 www.azimuthpress.com
 6040 Rue 132, Ste-Catherine
 QC J5C 1B6 CAN

PROPERTY AND CONFIDENTIAL
 THE INFORMATION CONTAINED IN THIS DRAWING IS THE
 SOLE PROPERTY OF AZIMUTH MACHINERY. ANY
 REPRODUCTION IN PART OR AS A WHOLE WITHOUT THE
 WRITTEN PERMISSION OF AZIMUTH MACHINERY
 IS PROHIBITED.

X:\4_Engineering\1_Products\4_Foodm\AZ-F2-AZ-F2-2001_Drawing

PAGE 1/1



ITEM NO.	PART NUMBER	DESCRIPTION	QTY.
1	AZ-F2-200-11001-00	PNEUMATIC CYLINDER	1
2	AZ-F2-200-11002-00	PISTON	1
3	AZ-F2-200-11003-00	CYLINDER	1
4	HNUT 0.7500-16-D-N		1

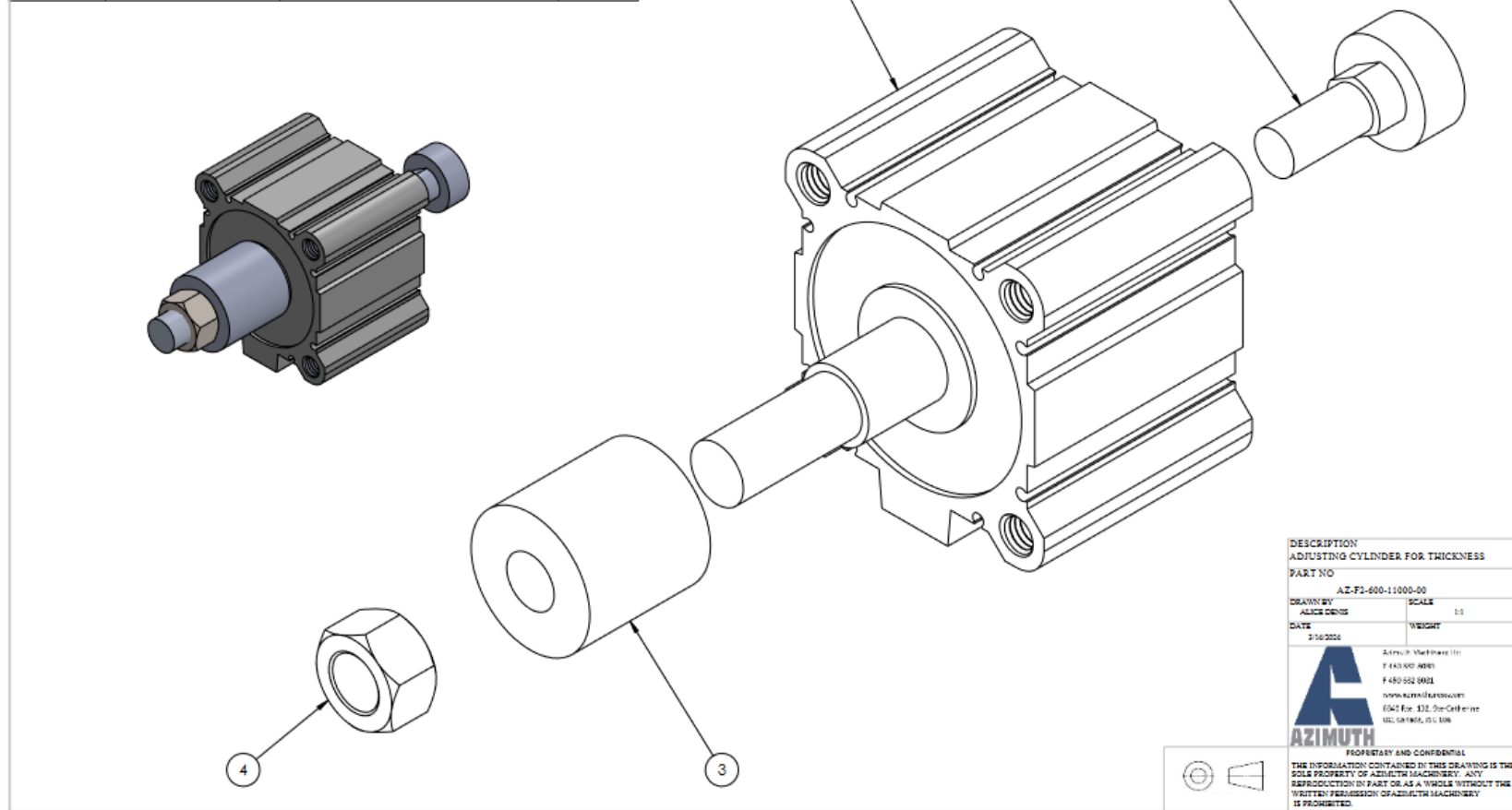

DESCRIPTION
 ADJUSTING CYLINDER FOR THICKNESS
 PART NO
 AZ-F2-600-11000-00
 DRAWN BY
 ALICE DENIS
 SCALE
 1:1
 DATE
 2/16/2024
 WEIGHT
 0.0000

Azimuth Machinery Inc.
 6040 Route 132, Ste-Catherine
 Quebec, Canada, J5C 1B6
 www.azimuthpress.com
 T. 450 632 8080

AZIMUTH
 PROPRIETARY AND CONFIDENTIAL
 THE INFORMATION CONTAINED IN THIS DRAWING IS THE
 SOLE PROPERTY OF AZIMUTH MACHINERY. ANY
 REPRODUCTION IN PART OR AS A WHOLE WITHOUT THE
 WRITTEN PERMISSION OF AZIMUTH MACHINERY
 IS PROHIBITED.

PAGE 1/1



AZ-F2-XXX DIMENSION:

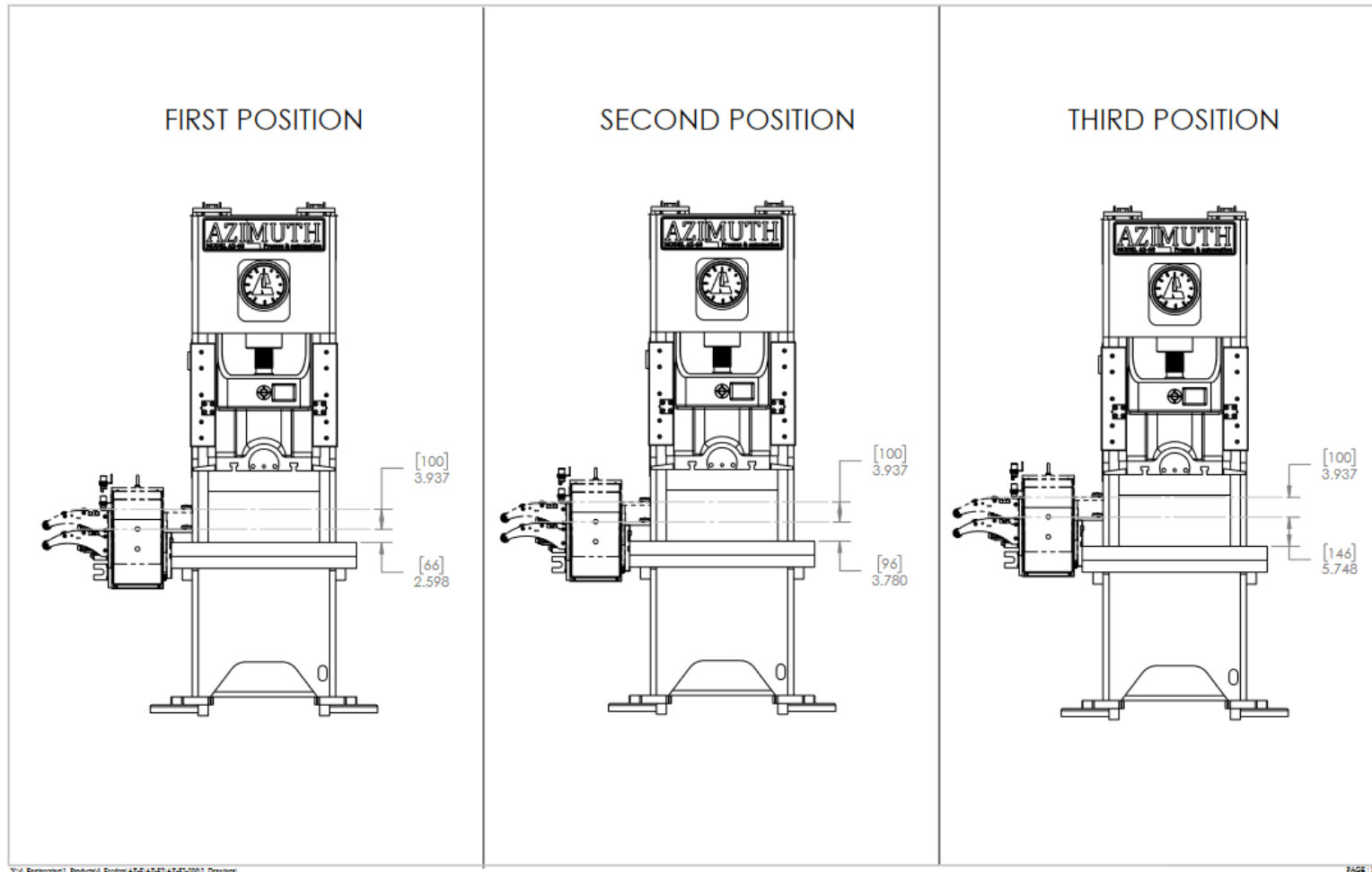

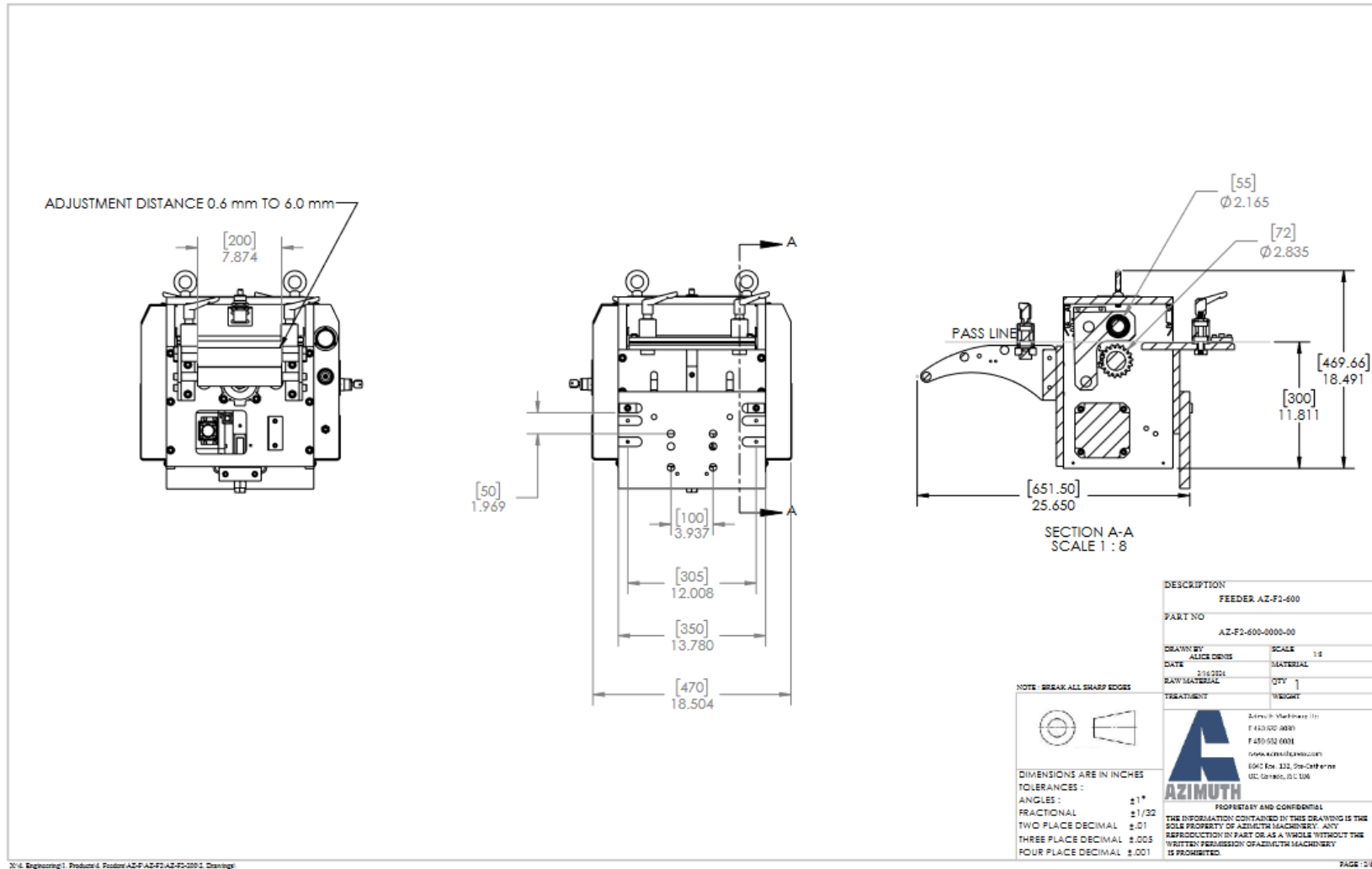

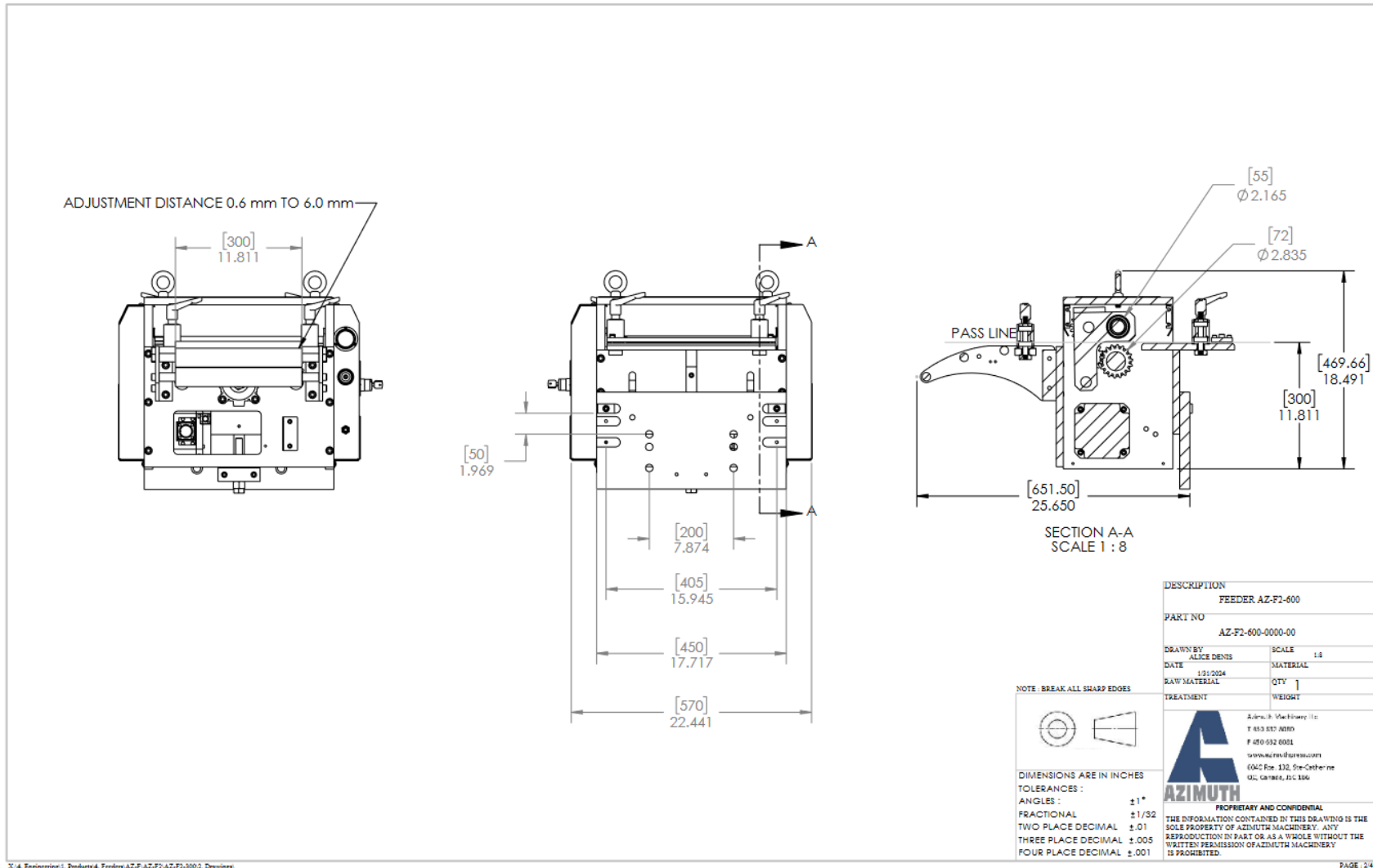

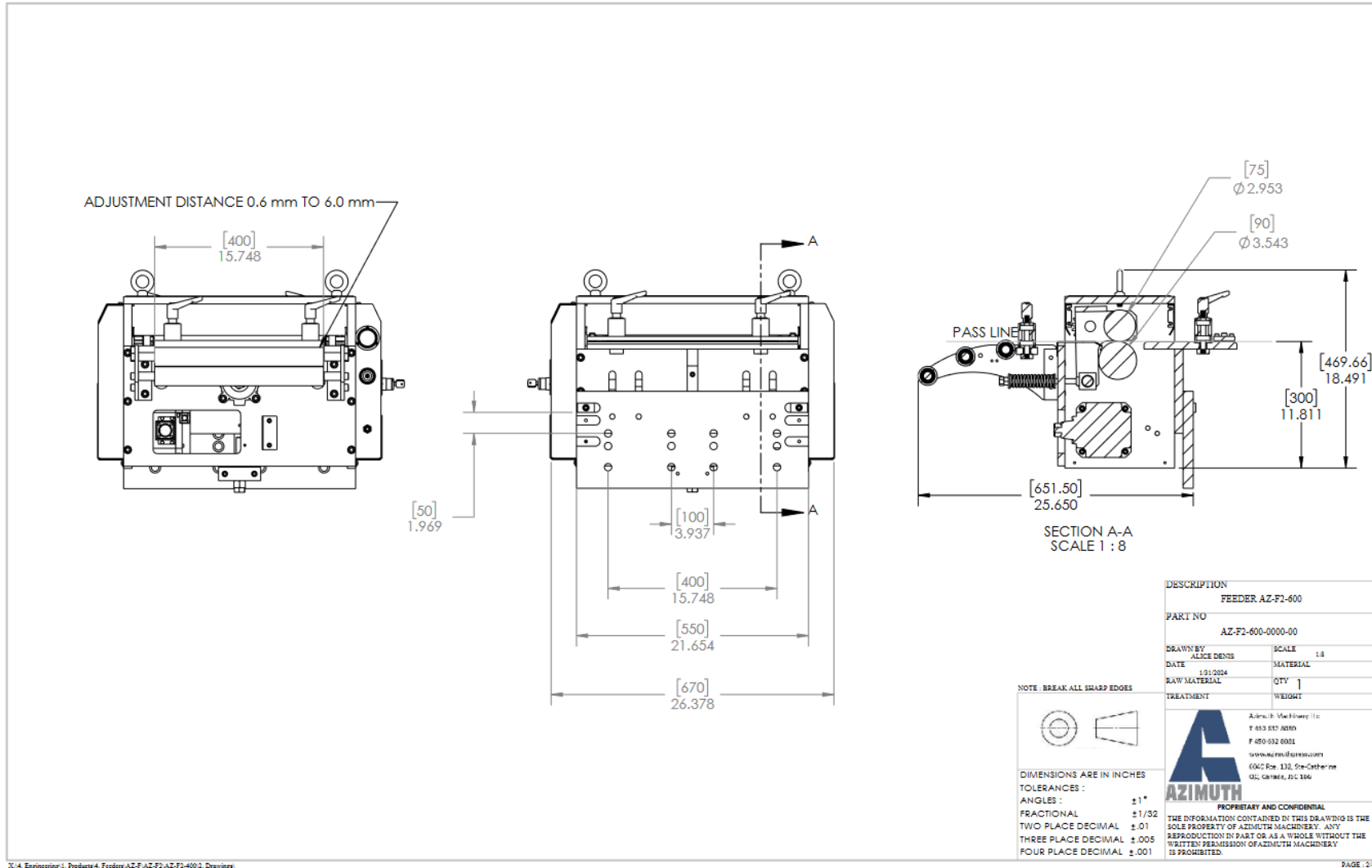

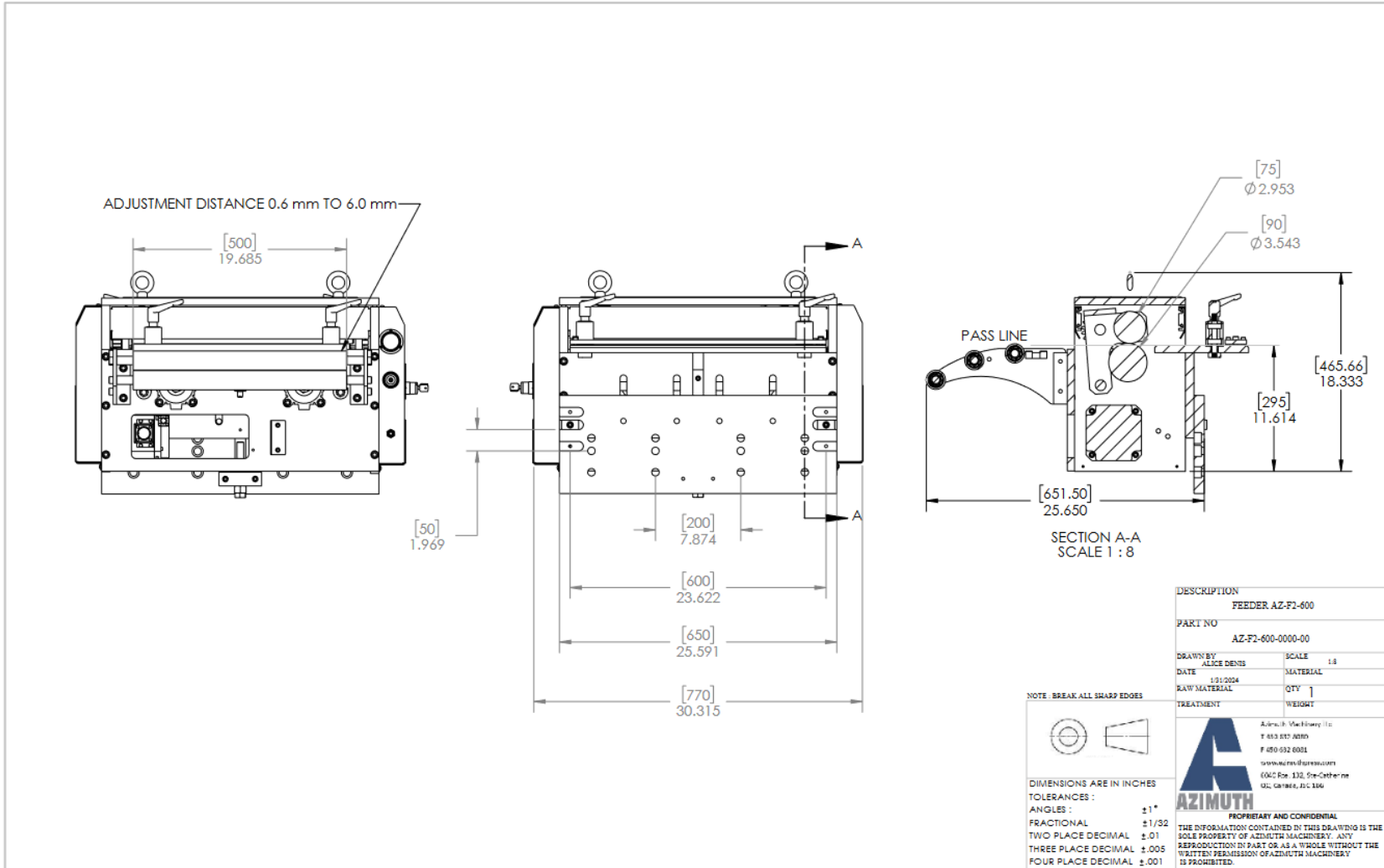

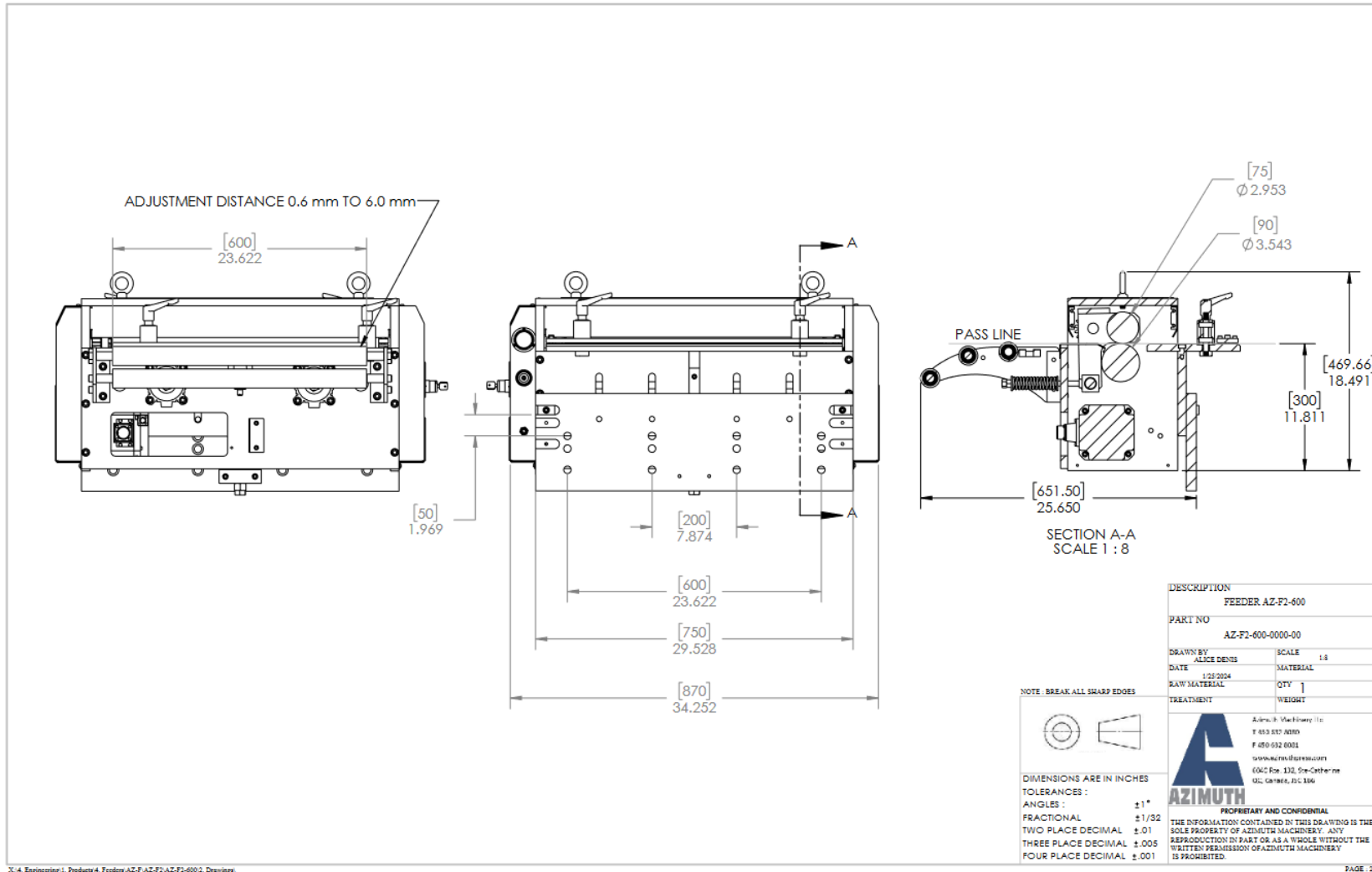



AZIMUTH MACHINERY
T. 450 632 8080 • sales@azimuthpress.com • www.azimuthpress.com
6040 Route 132, Ste-Catherine, Quebec, Canada, J5C 1B6



AZ-F3-XXX (INCOMING):



AZIMUTH MACHINERY
T. 450 632 8080 • sales@azimuthpress.com • www.azimuthpress.com
6040 Route 132, Ste-Catherine, Quebec, Canada, J5C 1B6

